

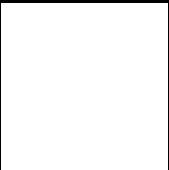

Booklet available in English on  
Heft in deutscher Sprache erhältlich auf  
Livret disponible en français sur  
Libretto disponibile in Italiano su  
Folleto disponible en español en  
如需中文版手册，请访问







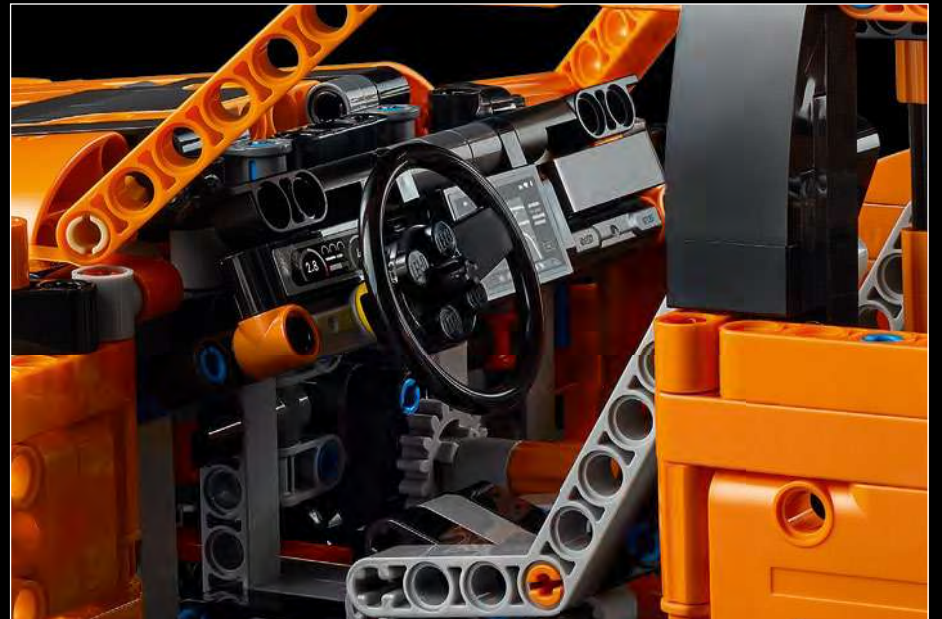

# **A WORKHORSE ON WHEELS**

It's difficult to imagine any other type of vehicle that symbolises America more than the pickup truck. Born over a century ago, the original rugged American pickup has been transformed through constant innovation into a state-of-the-art, modern luxury hauler.



## MODEL TT



If the Model T put America on wheels, the Model TT put it to work. With its 0.9-tonne (one US ton) payload and plentiful third-party pickup-bed configurations, this versatile workhorse became a regular sight on US roads.

## F-SERIES



The first-generation F-series marked Ford's new expanded truck strategy that offered a range of pickups in different sizes and with various hauling capabilities.

1917

1935

1948

1961

## FORD MODEL 50 PICKUP



Powered by the legendary Ford flathead V-8 engine, more than four million of these sturdy pickups were produced between 1935 and 1941.

## FOURTH GENERATION



With the slogan "Drives like a car, works like a truck", this was the first pickup to also be targeted at non-commercial truck users.

## SIXTH GENERATION



Continuing to make comfort a priority, this latest F-150 introduced a much-improved heating and air-conditioning system. To increase safety, the fuel tank was also moved out of the cab.

## TENTH GENERATION



Focusing on personal use, the F-150 was given a dramatic re-design, including a new V6 engine and four full-size doors. Modern lines and new technology earned the F-150 an increase in sales and a Truck of the Year award.

**1973**

**1987**

**1997**

**2009**

## EIGHTH GENERATION



This generation went through many revised body panels and redesigns interior. Most importantly, this generation saw the introduction of electronic fuel injection engines making the F-150 more powerful and efficient.

## TWELFTH GENERATION



With 50.8 cm (20 in.) chrome wheels, leather upholstery and heated and ventilated seats, this generation of the F-150 offered a new level of luxury for customers.



## **THE 3<sup>RD</sup> GENERATION FORD F-150 RAPTOR**

It's been a long journey from the first Model TT to the latest 2021 incarnation of the F-150 Raptor, but the spirit remains very much the same. Created by Ford Performance, the Raptor is

a high-performance, street-legal truck and one of the most capable factory off-road vehicles. It combines the most powerful engine in the F-150 range with rugged off-road-ready suspension.



“

**QUALITY MEANS DOING IT RIGHT  
WHEN NO ONE IS LOOKING”**

Henry Ford





# FROM THE DESIGN TEAM

The LEGO® Technic design team worked closely with the designers and engineers at Ford to ensure the Technic version of the F-150 Raptor would be as close to the real thing as possible. The biggest challenge for the team was to create a rear-axle configuration and suspension structure that would allow the rear wheels and wheel arches to perfectly align.

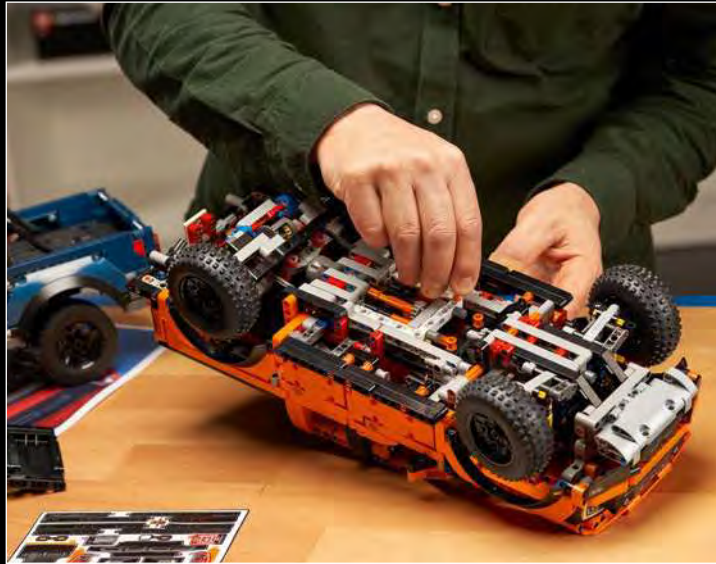

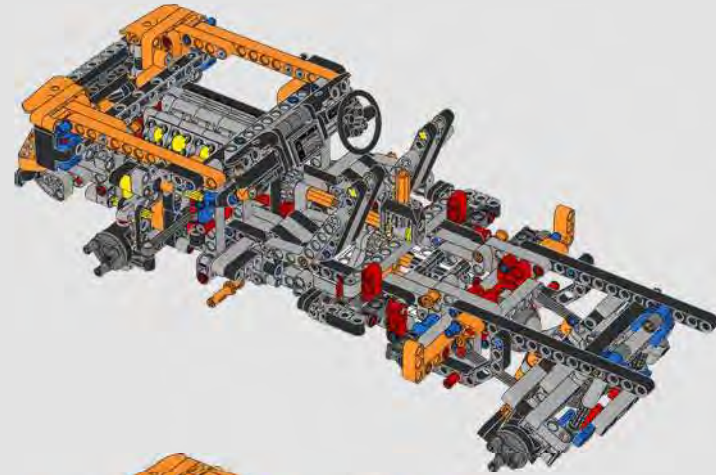
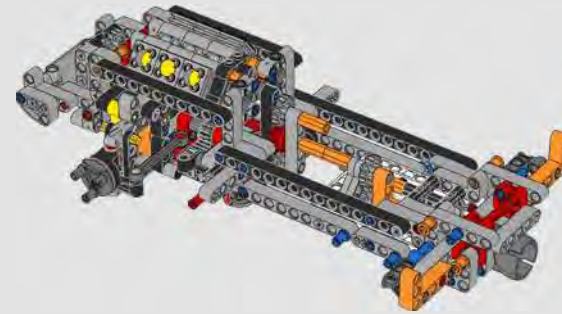

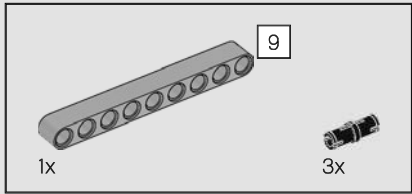
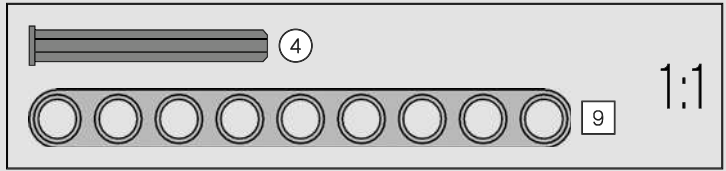
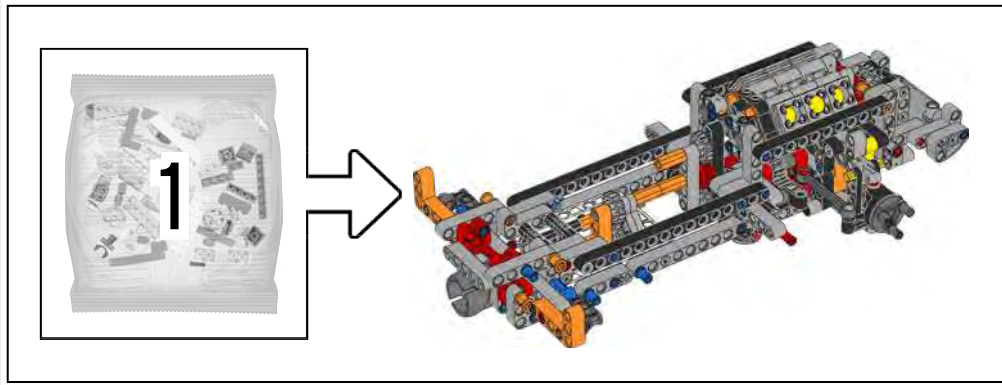

1

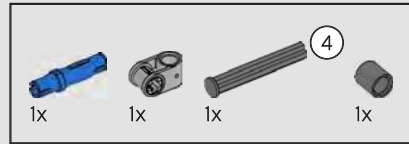
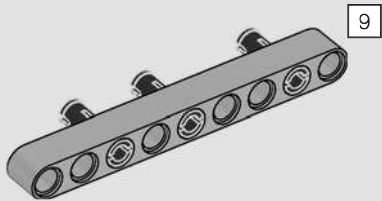

2

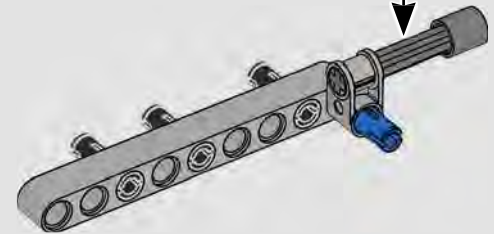
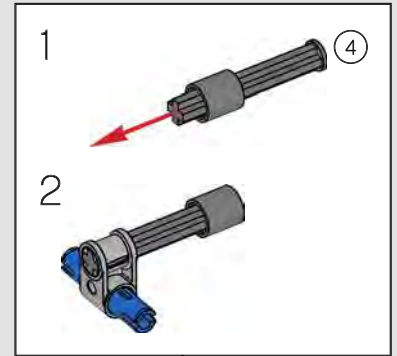

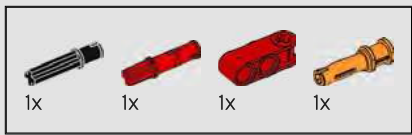

3

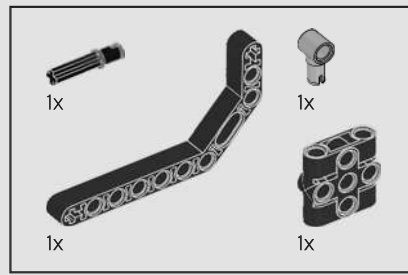
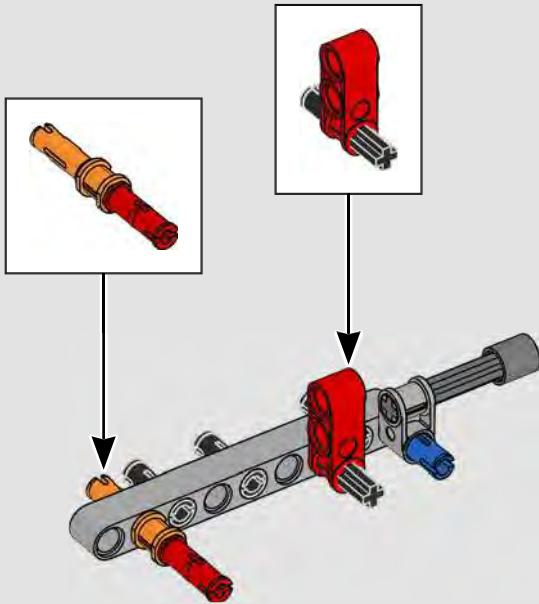

4

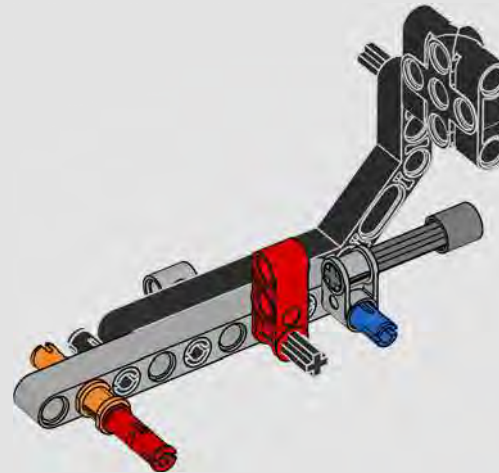
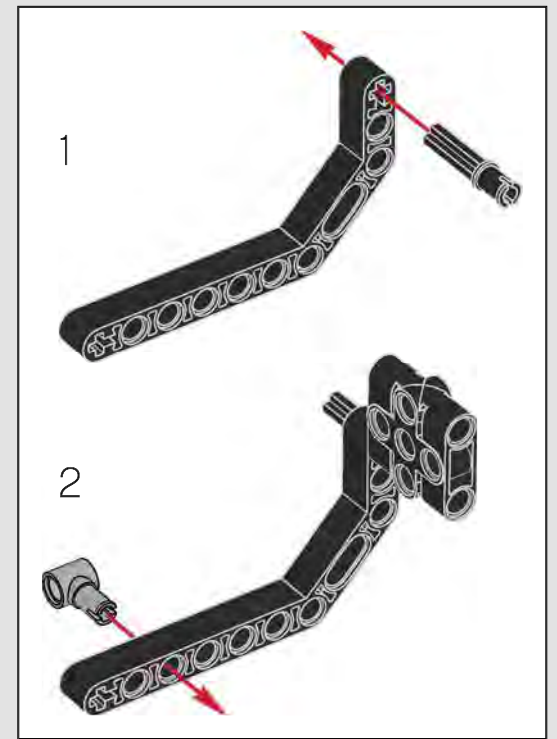

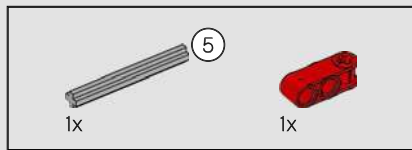

5

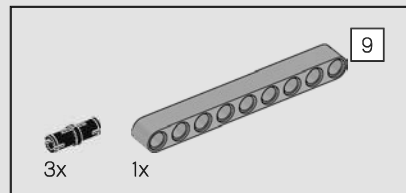
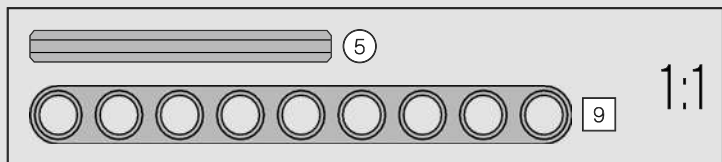
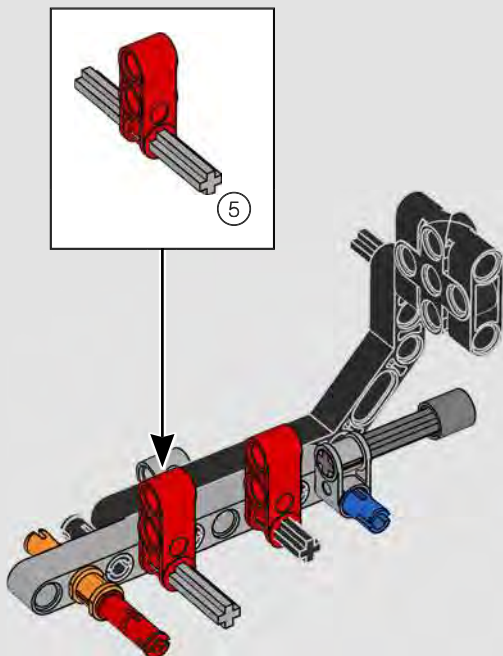

6

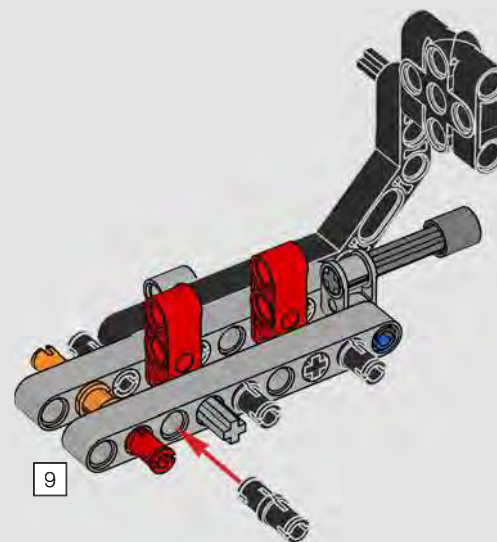

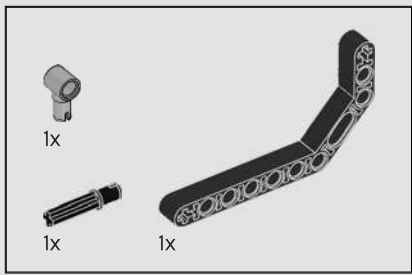

7

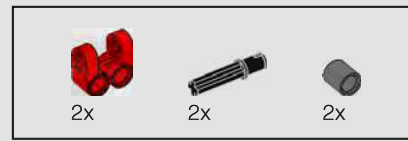
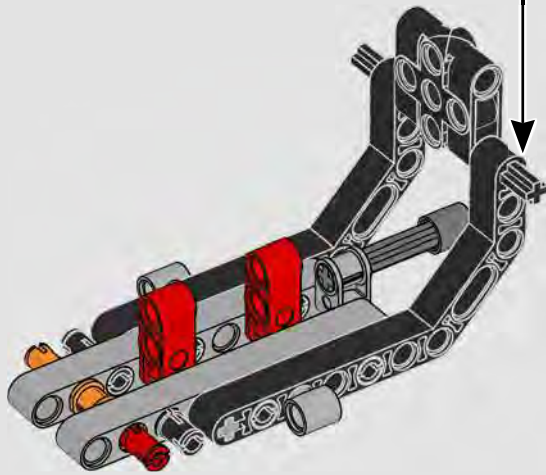

8

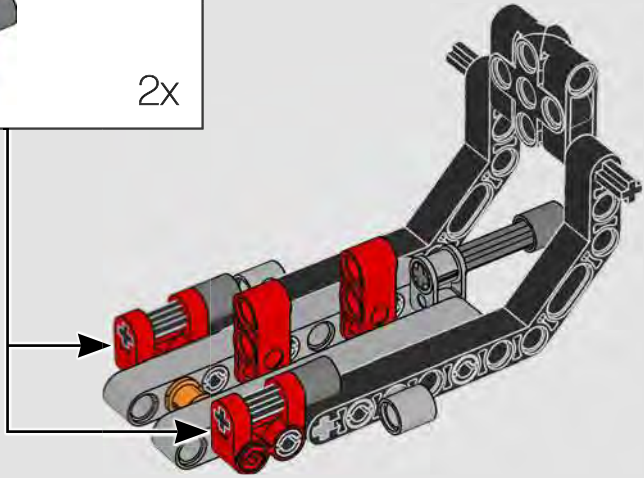
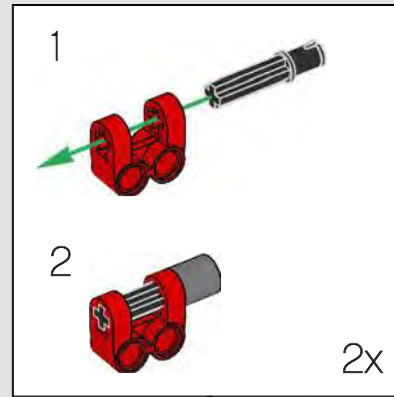



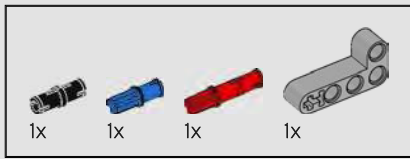

9

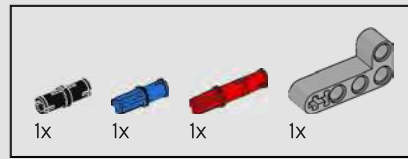
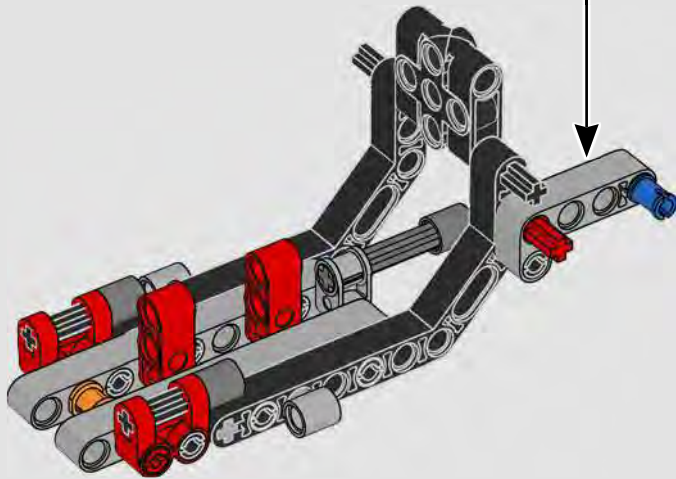
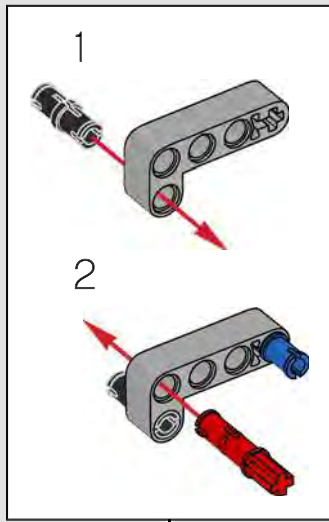

10

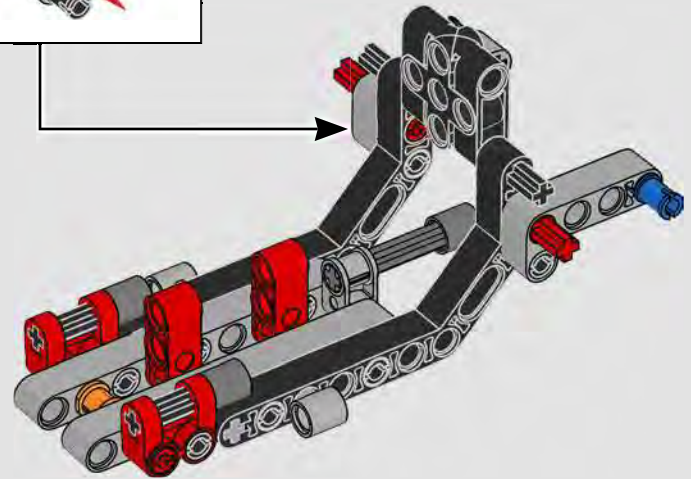
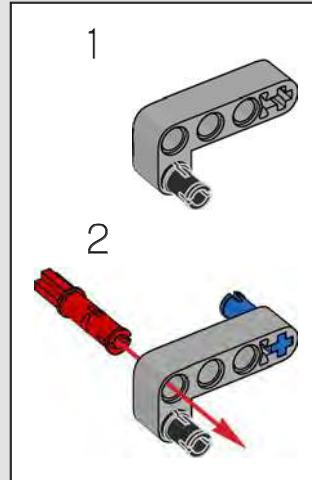



11

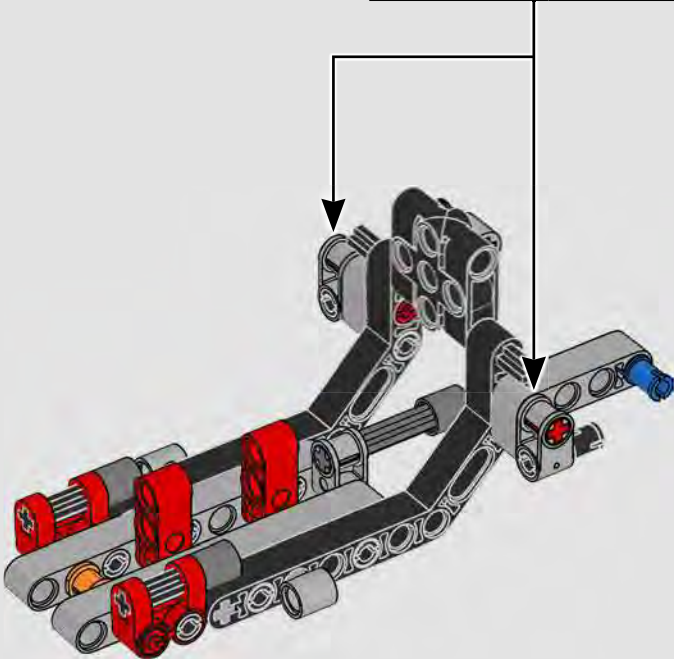

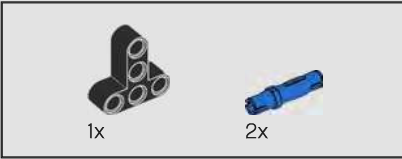
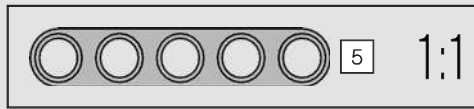
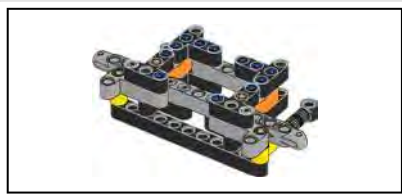

12

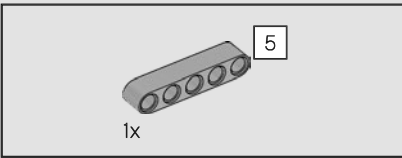
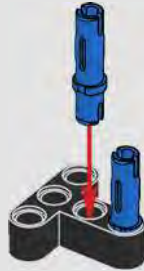

13

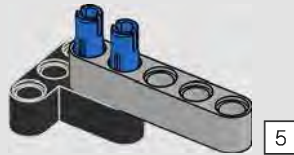

14



15

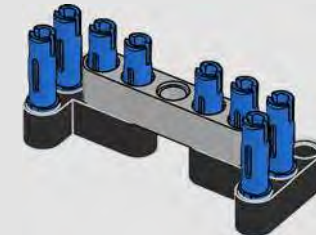



16

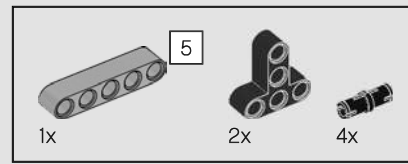
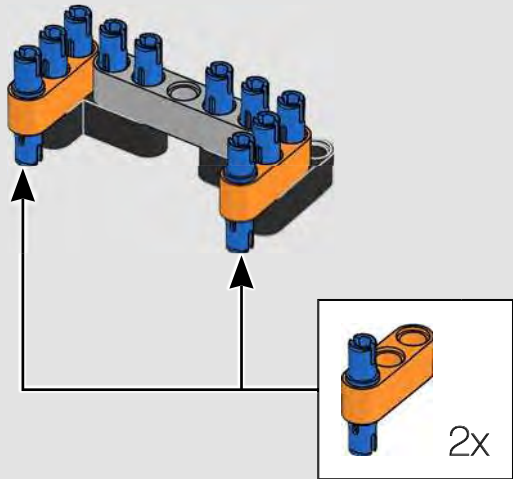

17

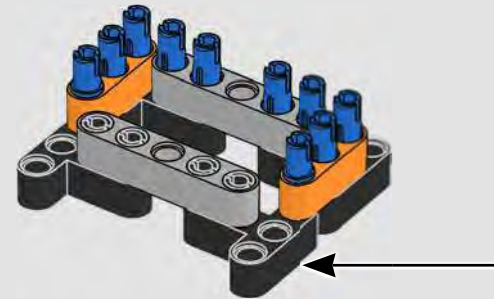
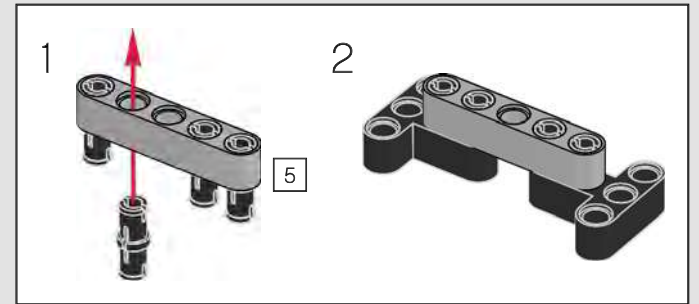
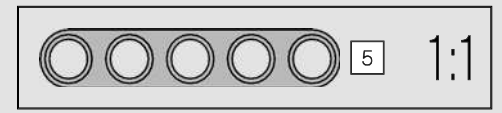

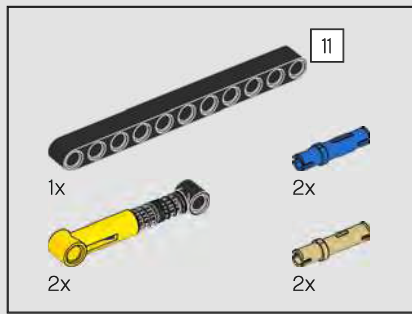

18

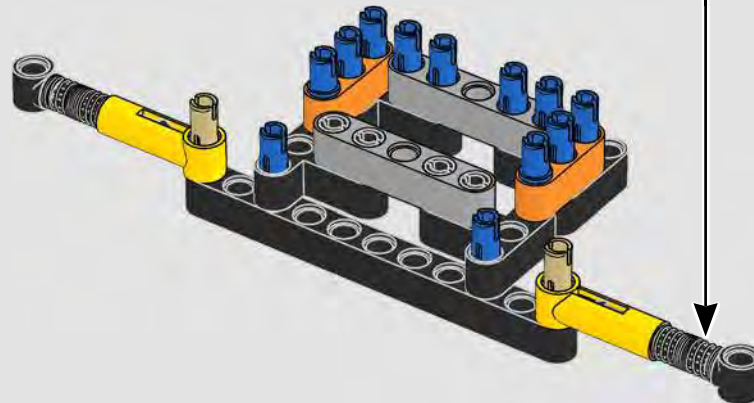
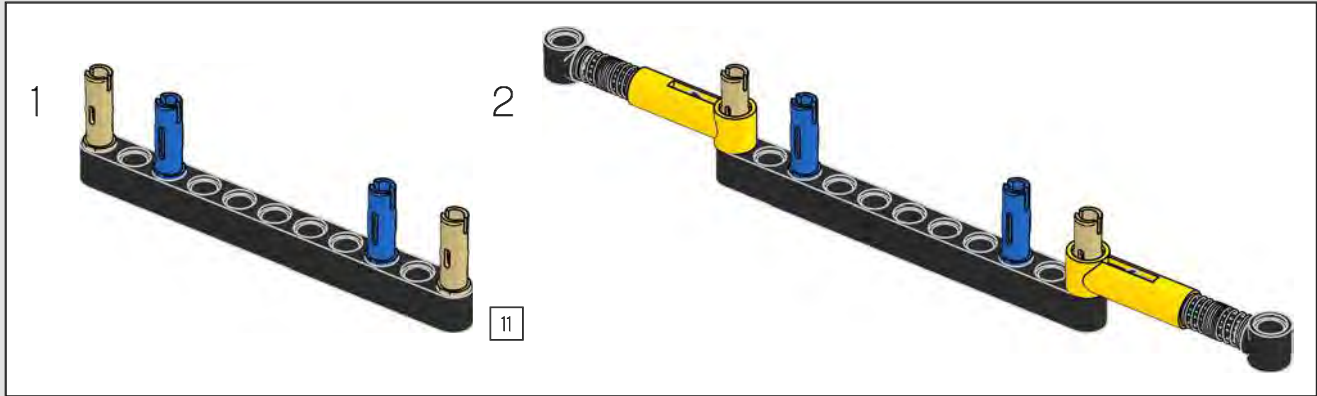

*The F-150 Raptor is outfitted with FOX™ Live Valve monotube shocks that automatically adjust to the driving terrain.*



19

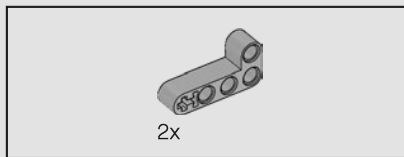
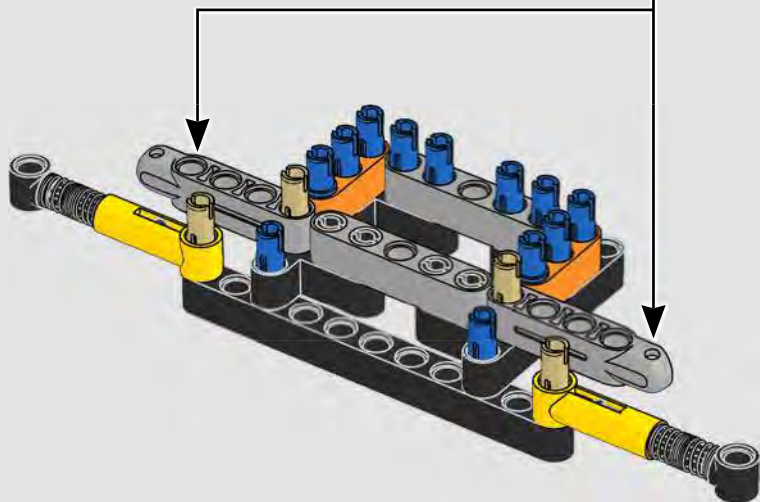
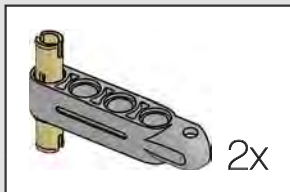
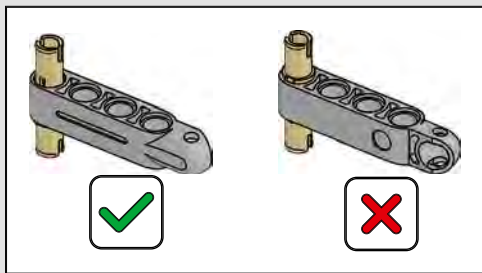

20

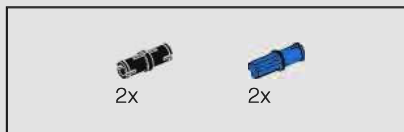
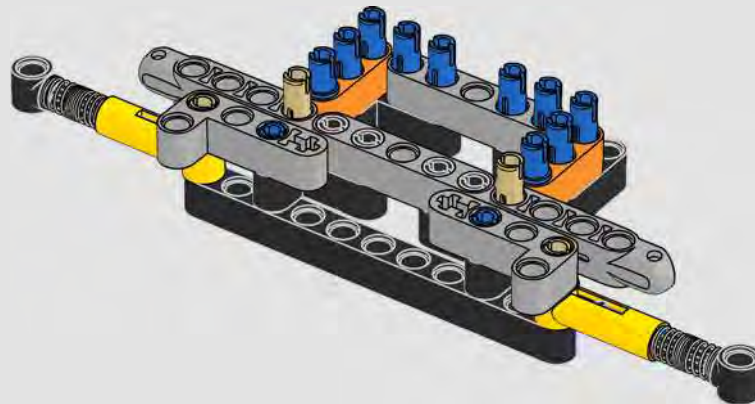

21

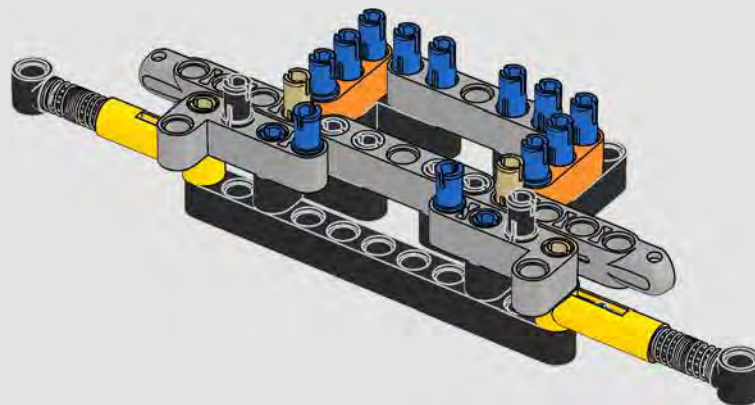

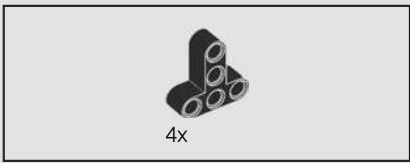

22

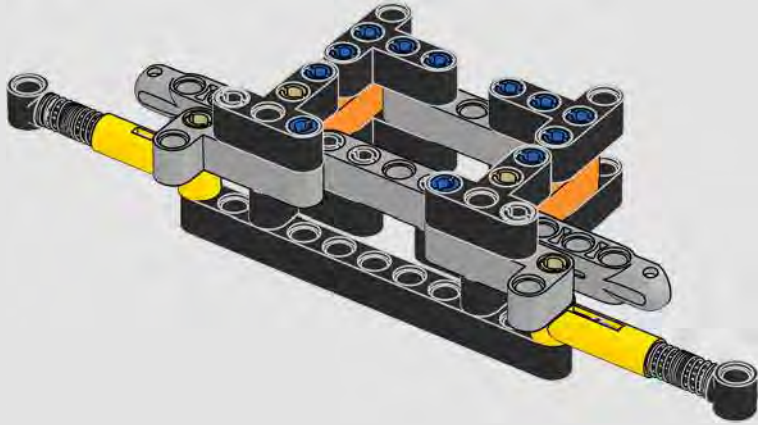

23

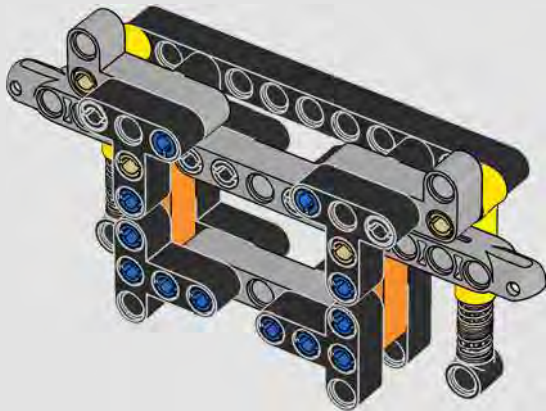

24

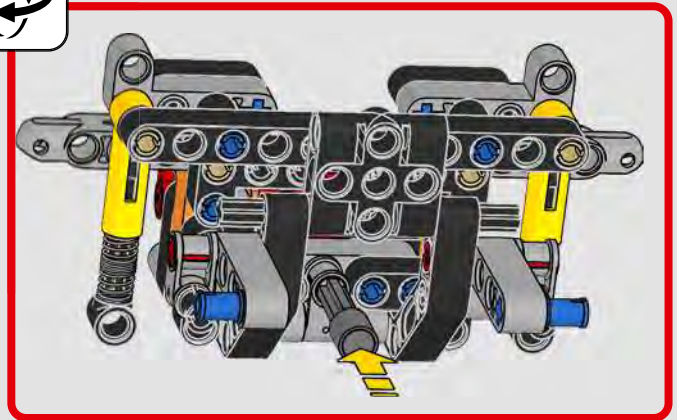
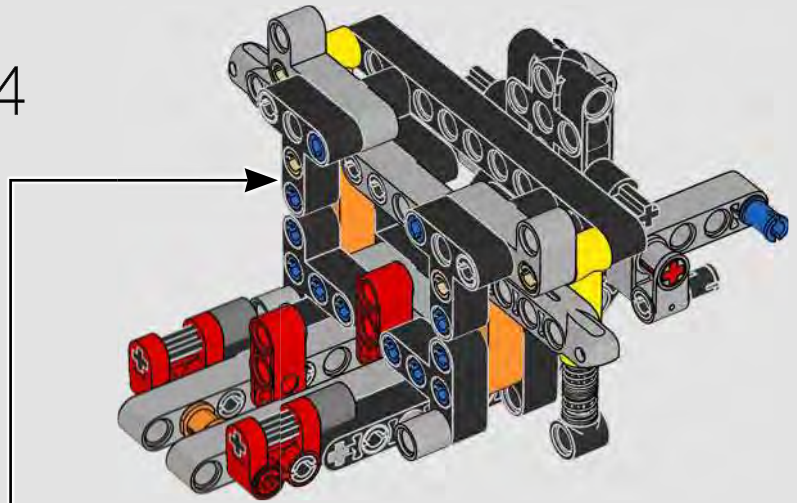

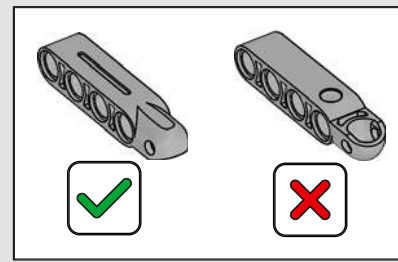
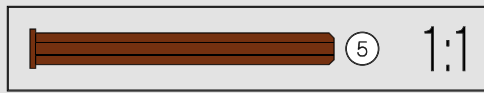
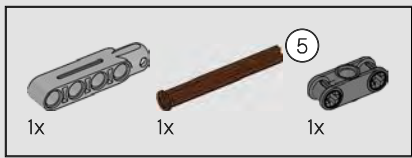

25

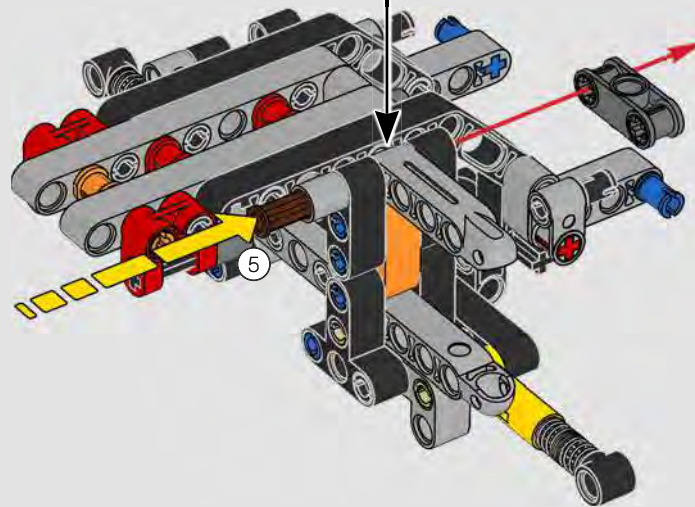
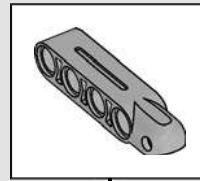



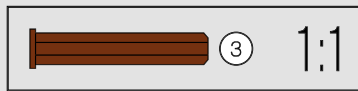

26

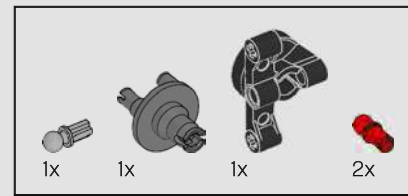
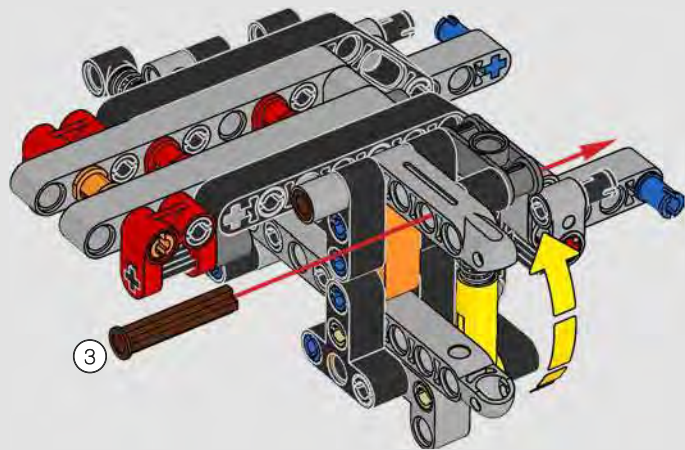

27

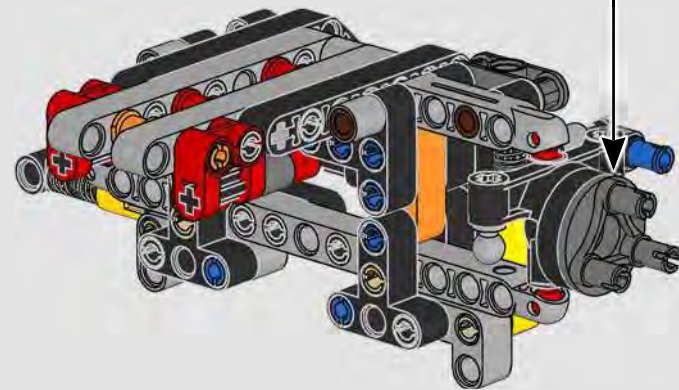
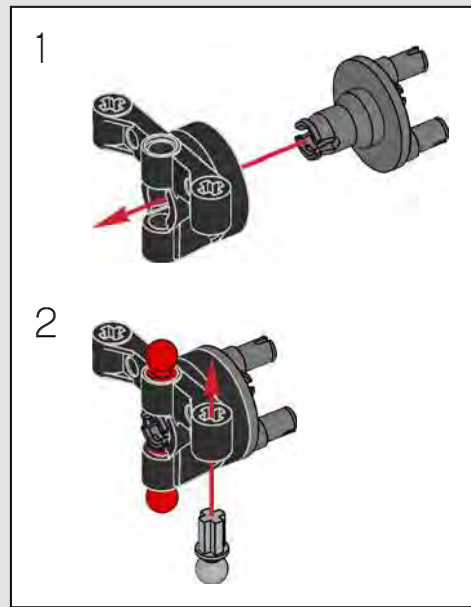

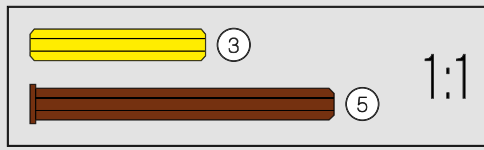
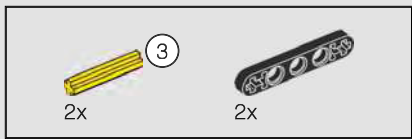

28

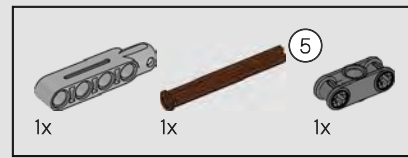
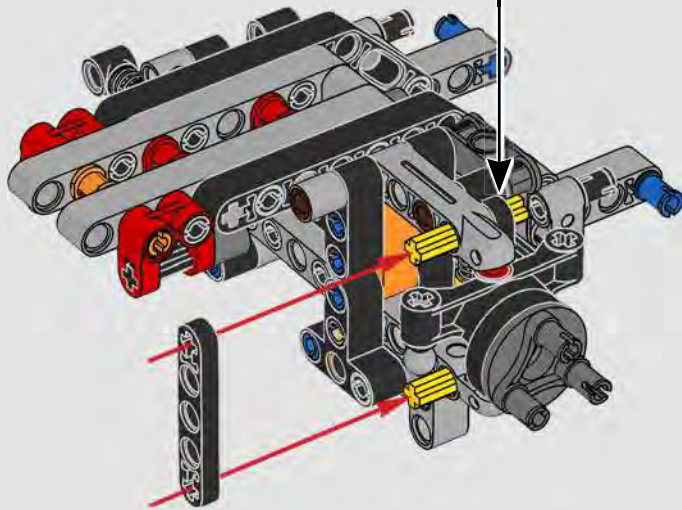
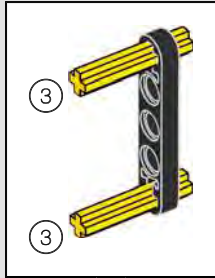

29

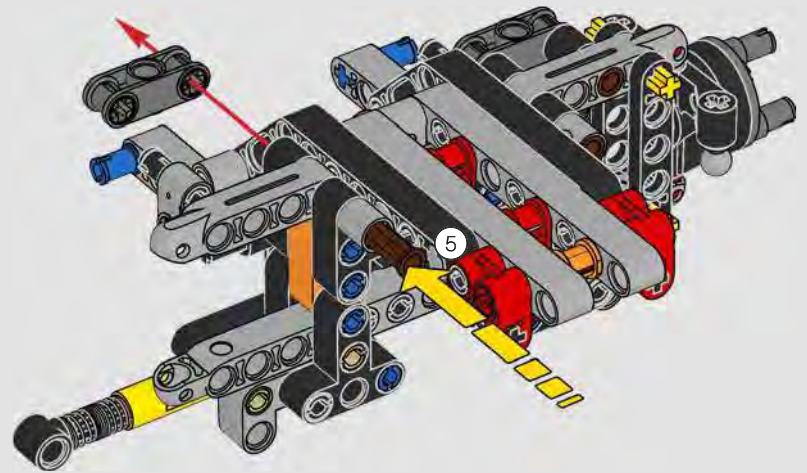
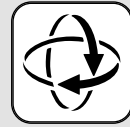

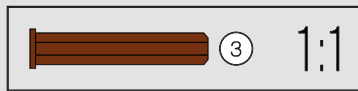
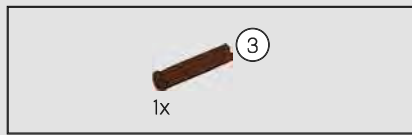

30

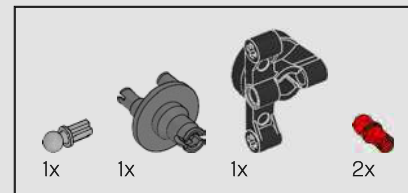
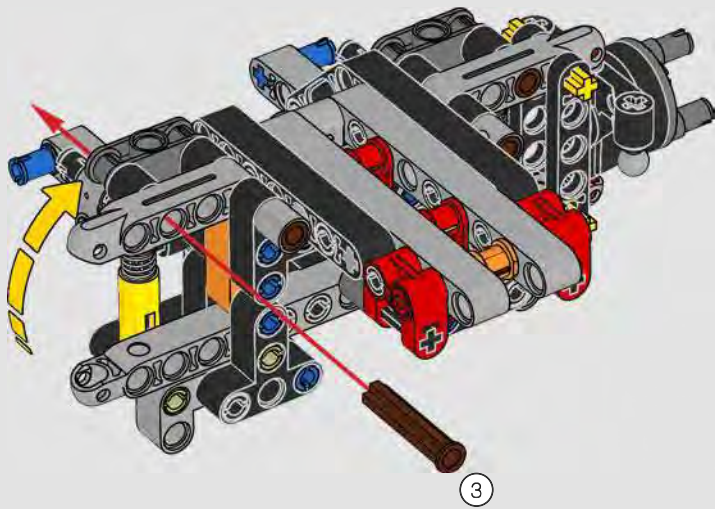

31

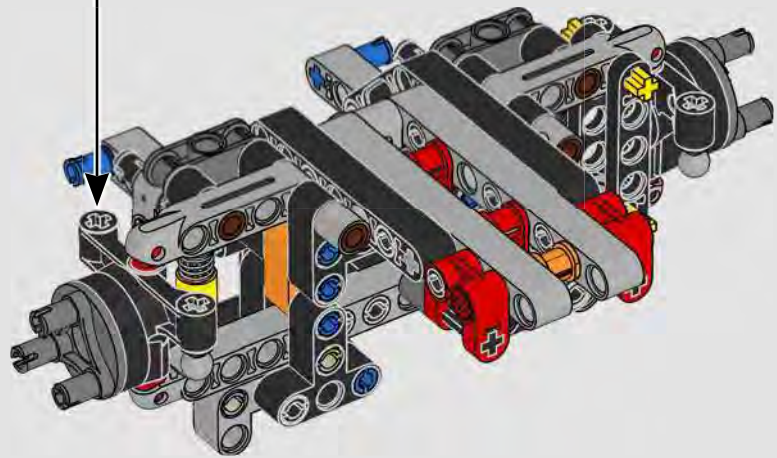
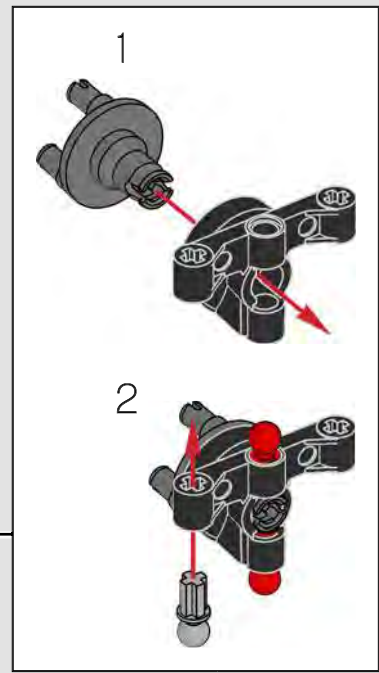

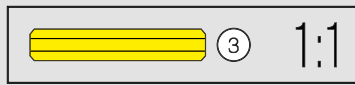
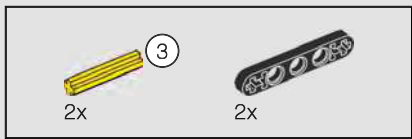

32

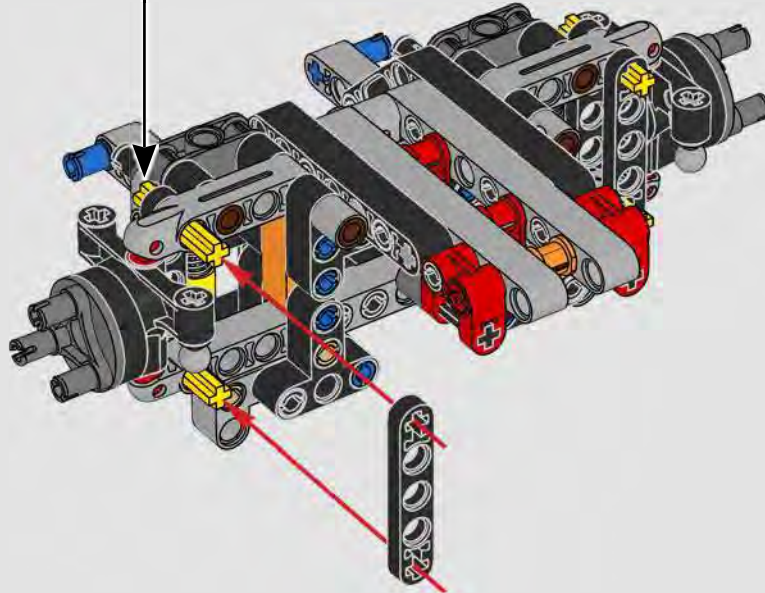
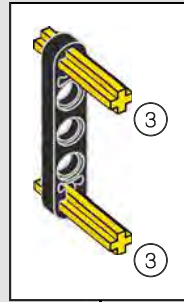

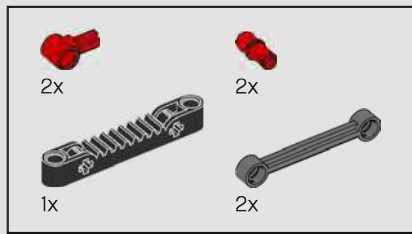

33

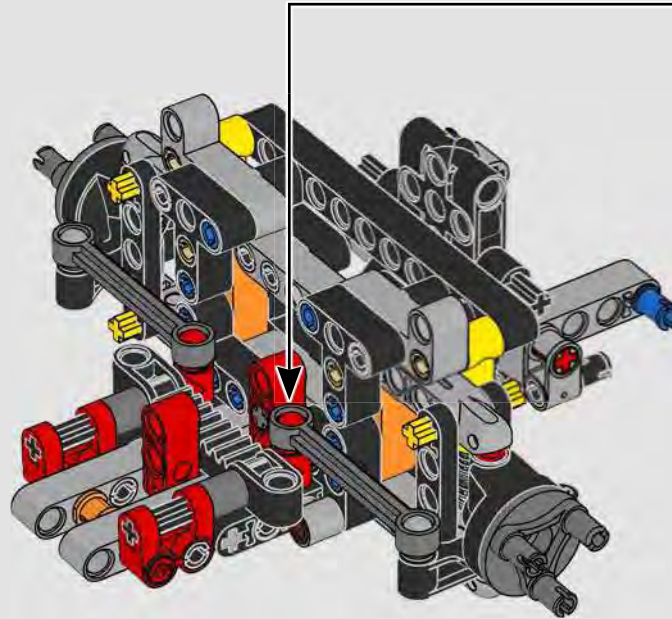
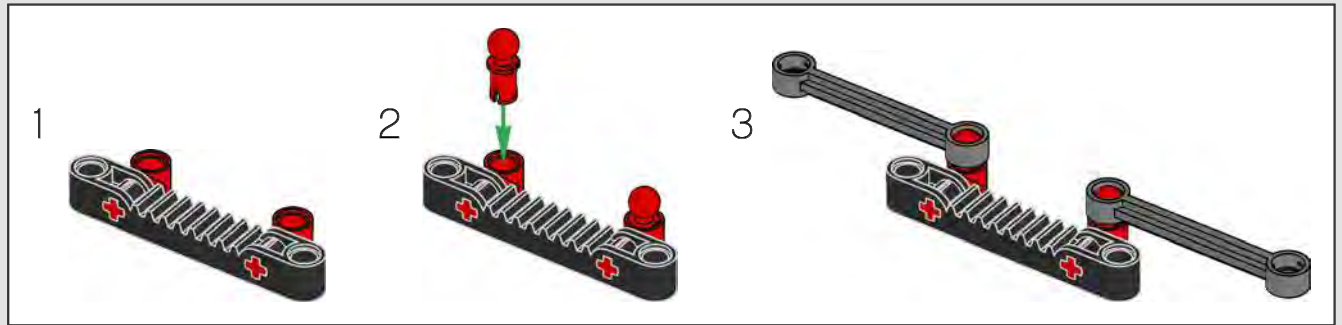

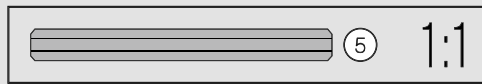
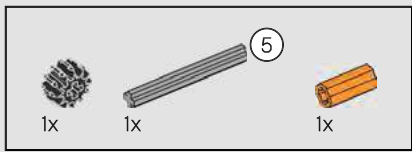

34

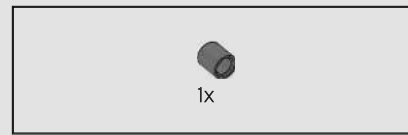
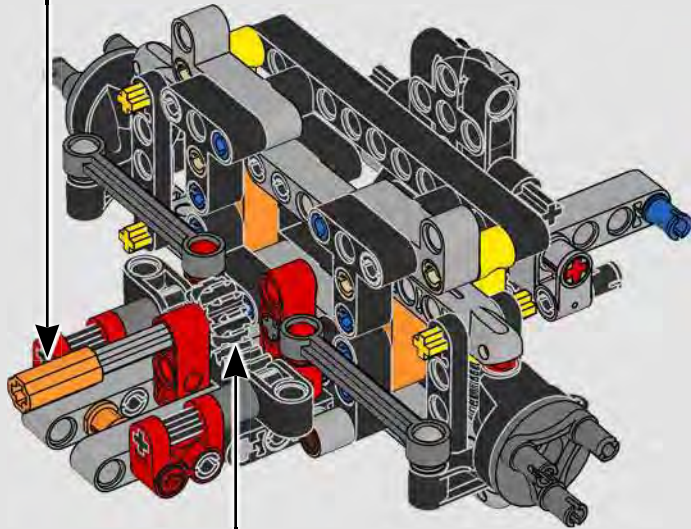
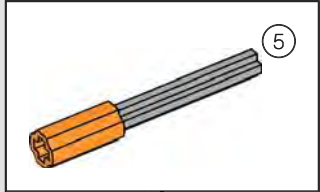

35

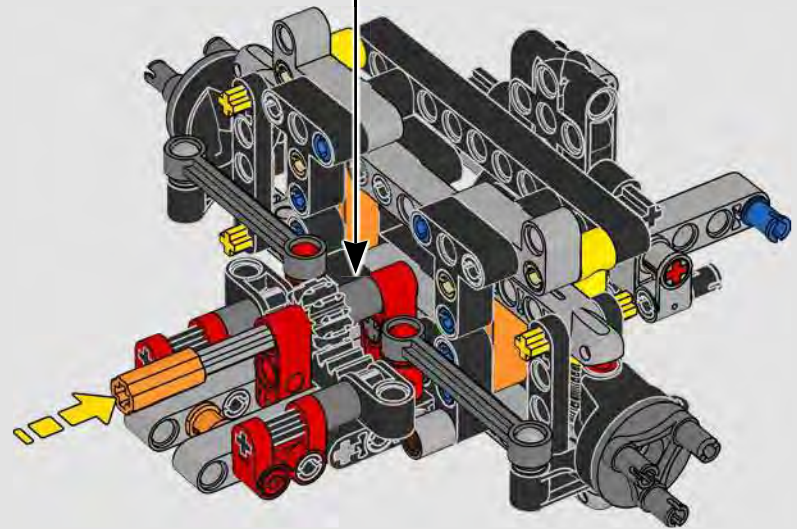

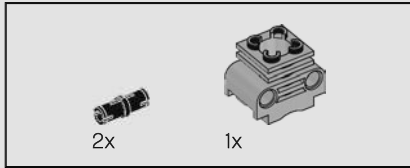
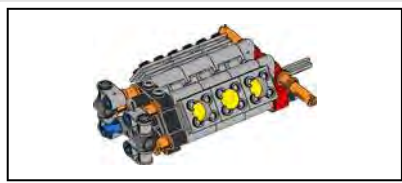

36

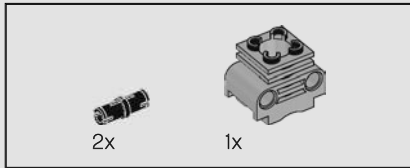
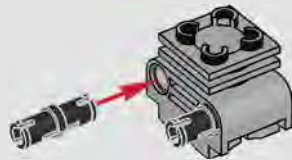

37

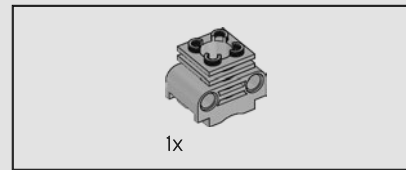
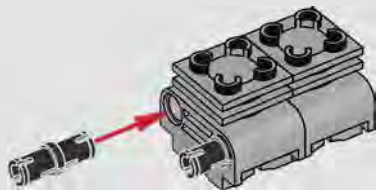

38

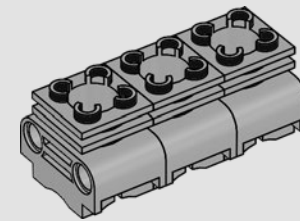

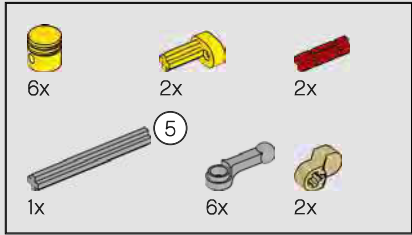
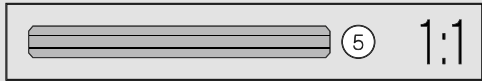
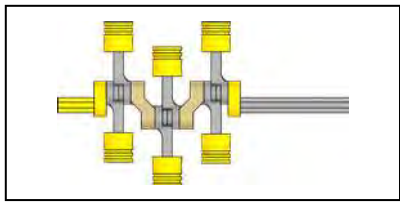

39

1

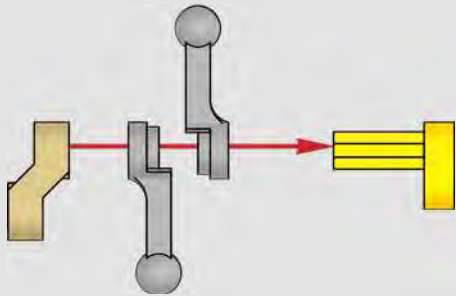

2

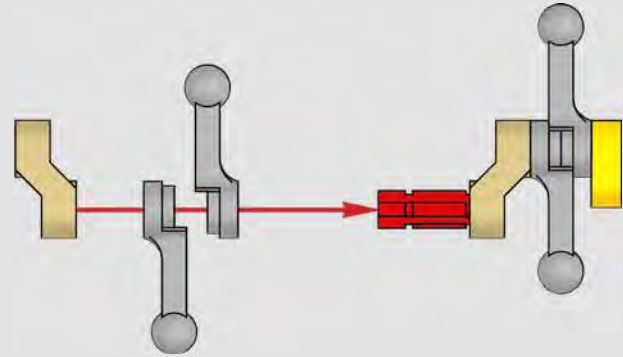

3

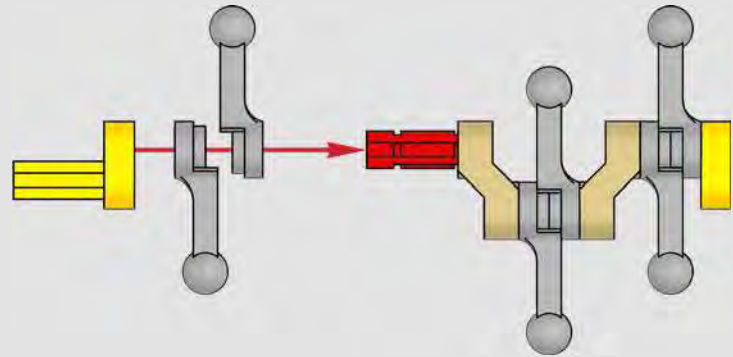



4

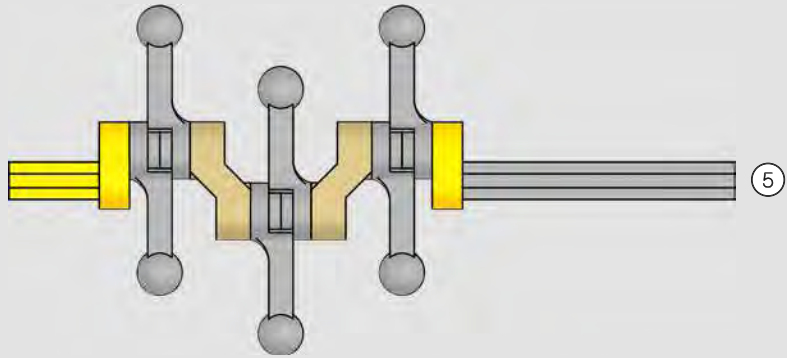

5

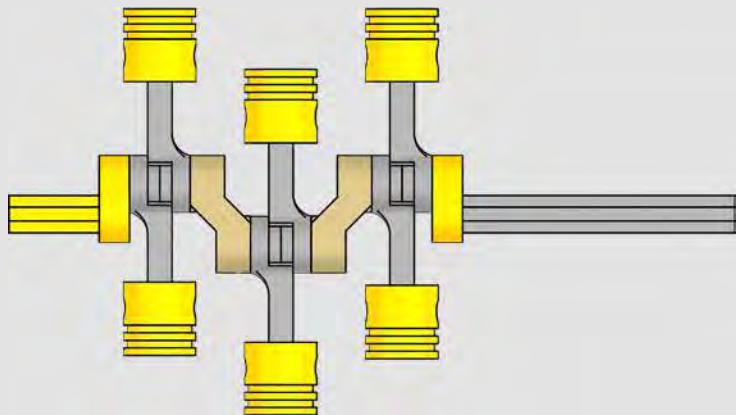

1:1

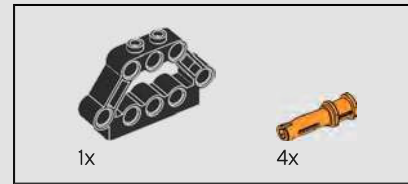
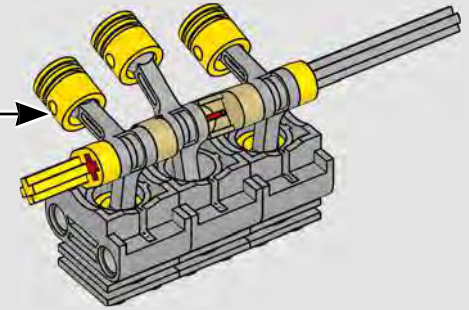
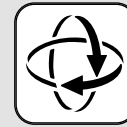

40

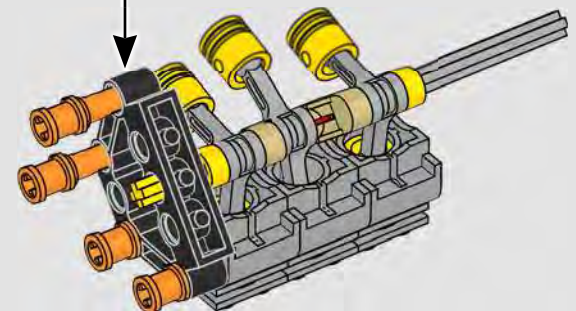
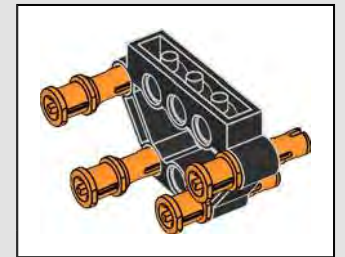

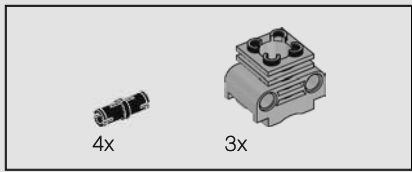

41

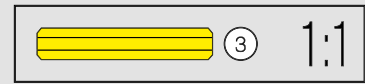
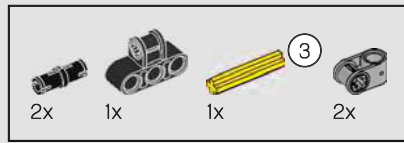
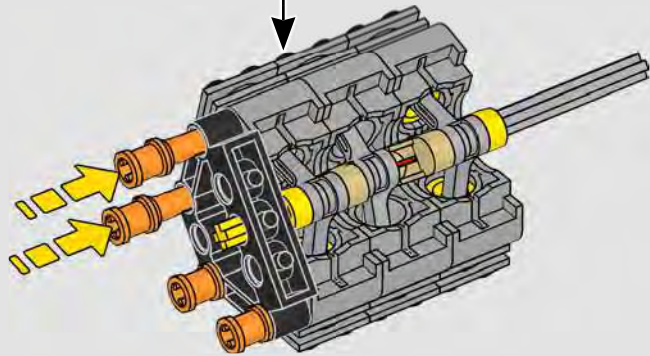
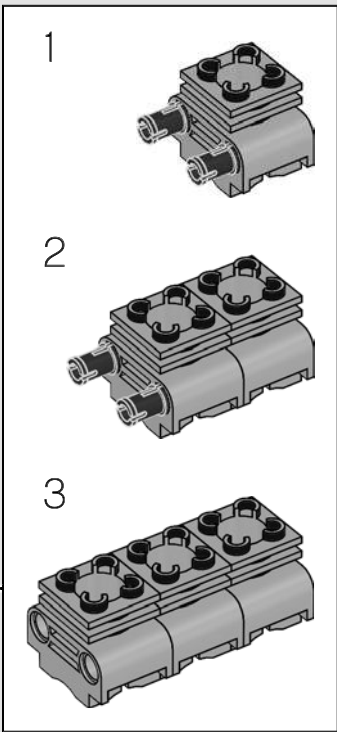

42

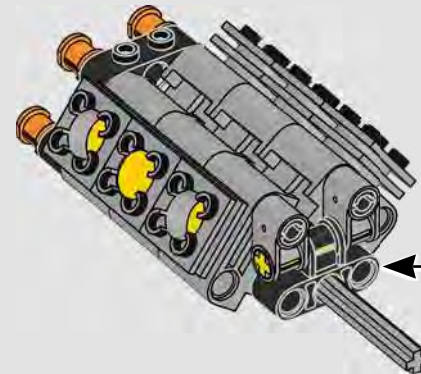
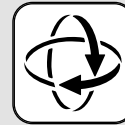
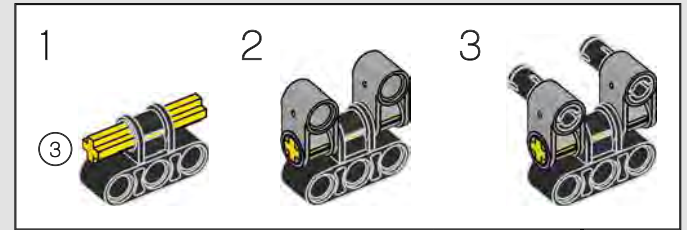

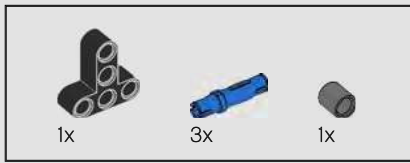

43

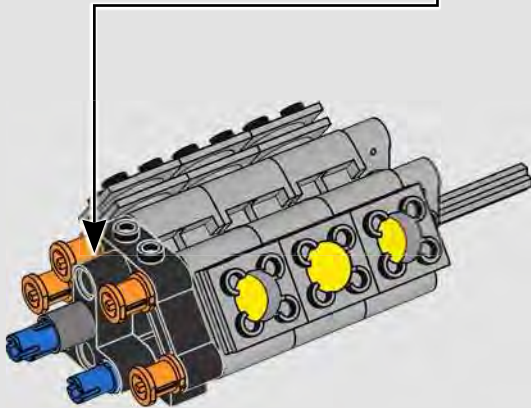
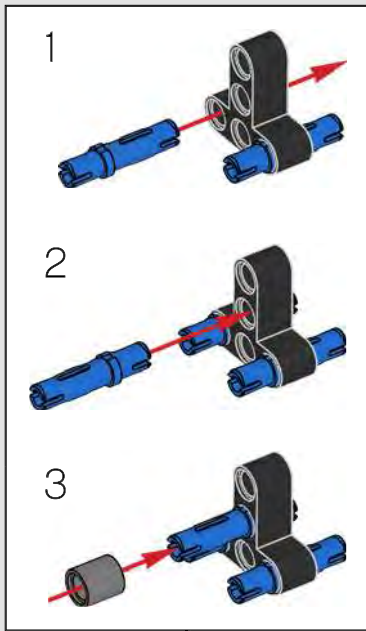

44

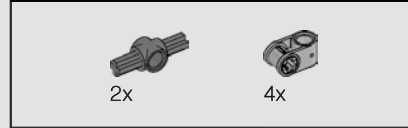
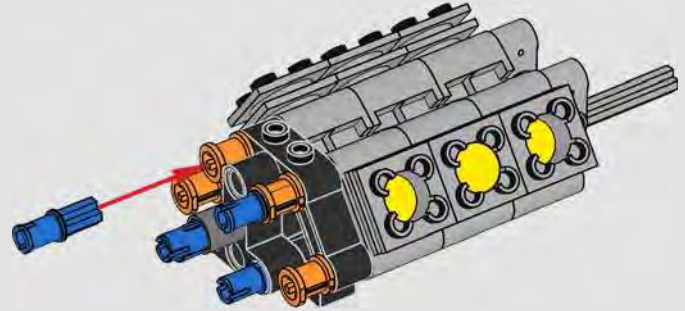

45

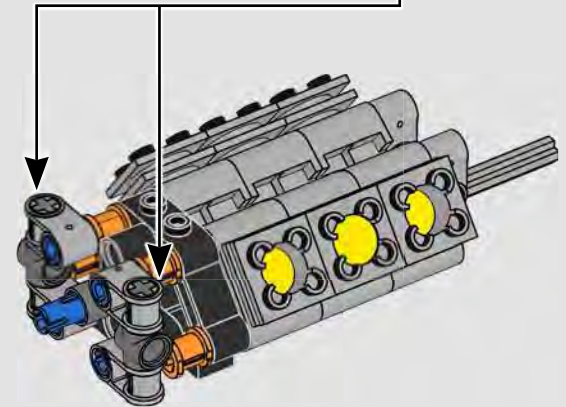
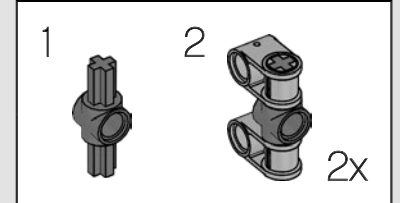

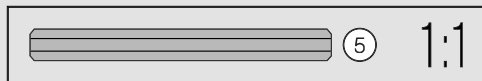
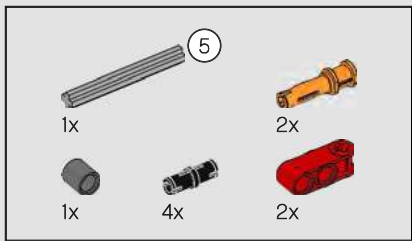

46

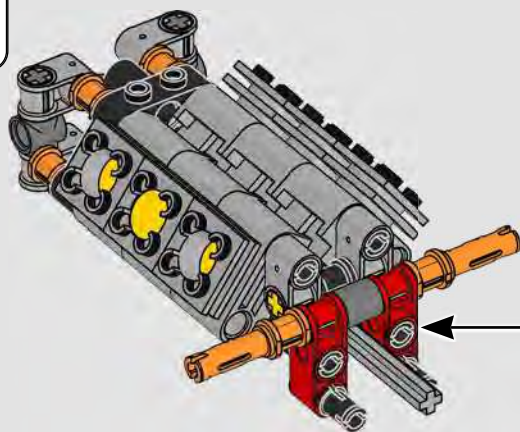
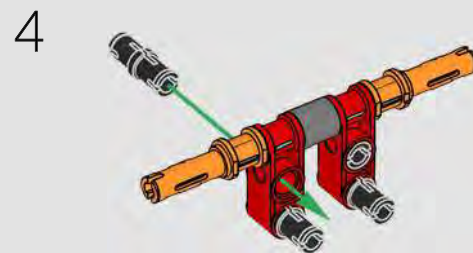
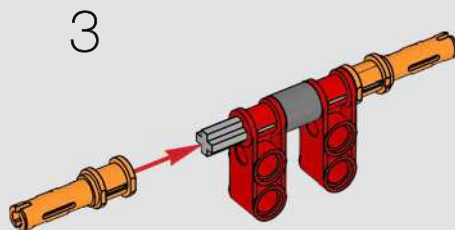
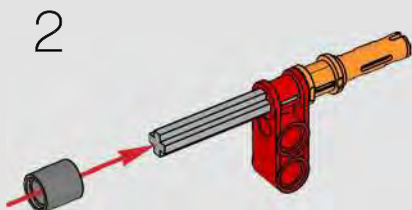
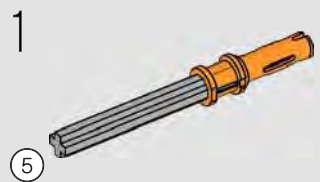

47

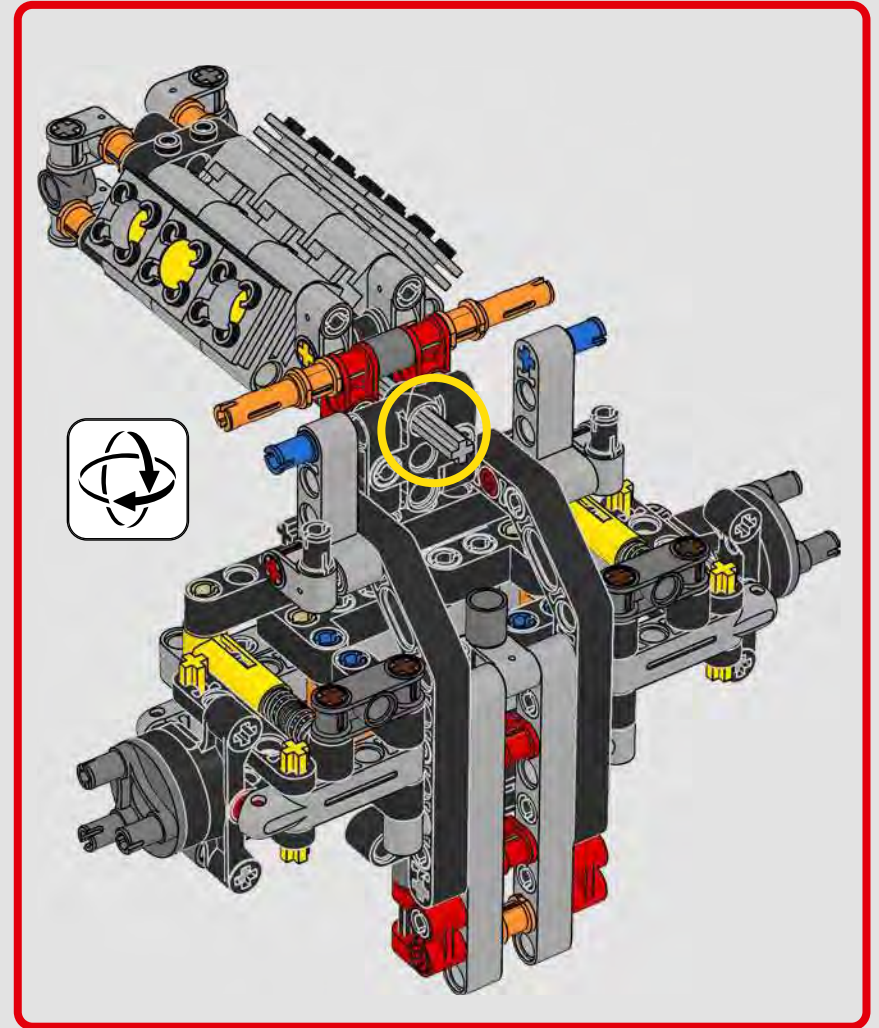
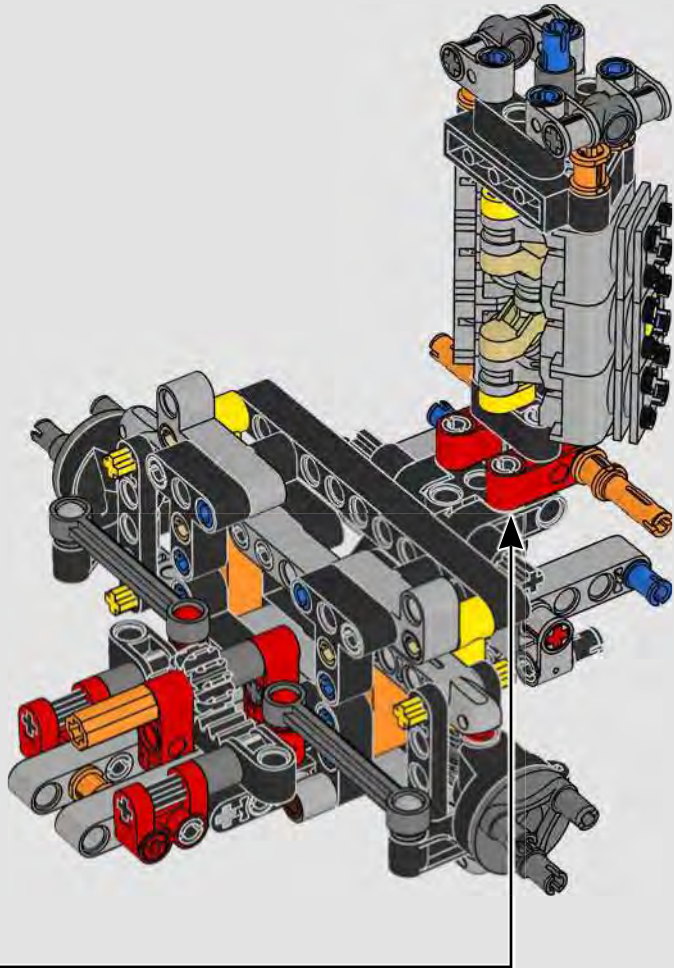



1x

48

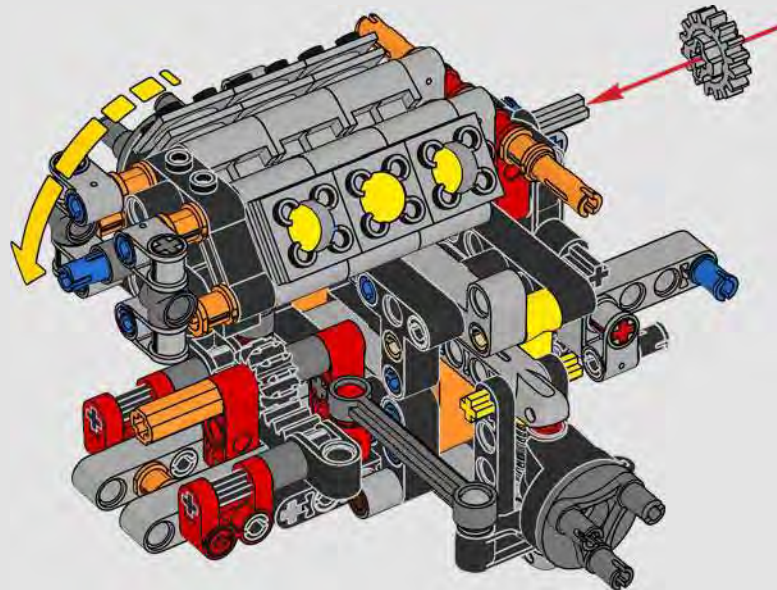

*Under the hood is a 24-valve, 3.5L twin-turbo HO V6 with Ford's dual-fuel port and direct injection, and 10-speed automatic transmission.*

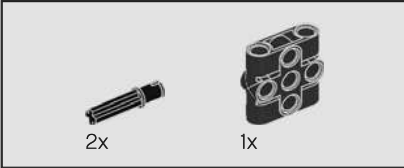
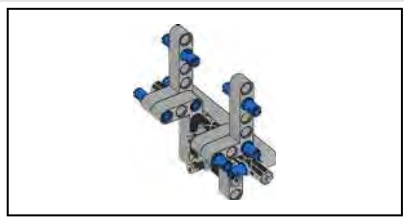

49

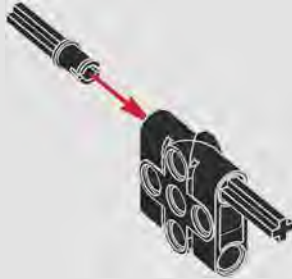

50

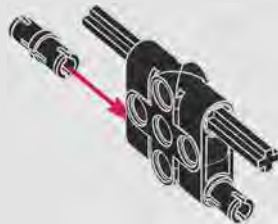

51

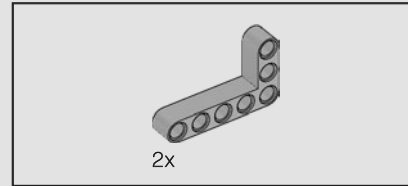
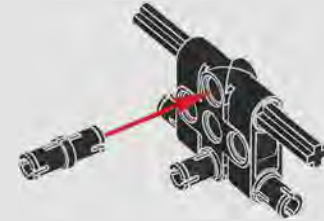

52

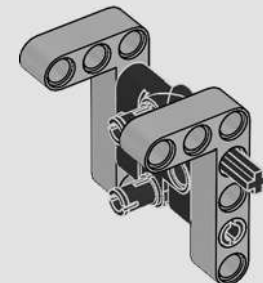



53

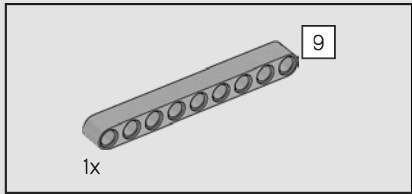
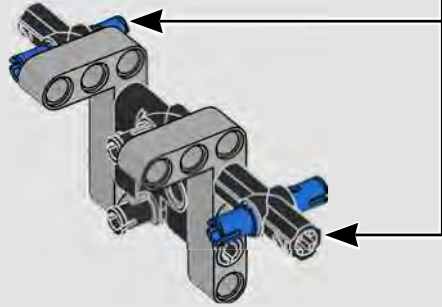

54

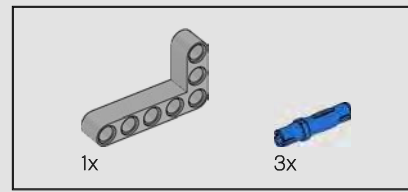
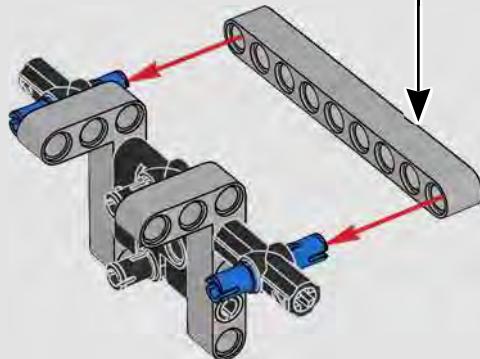
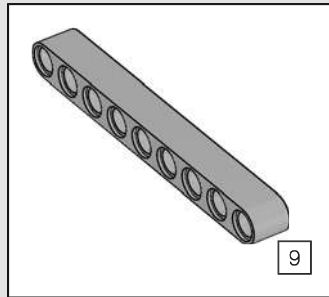

55

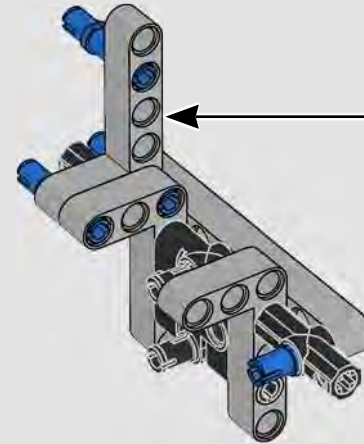
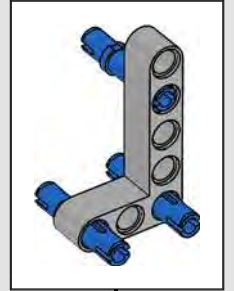



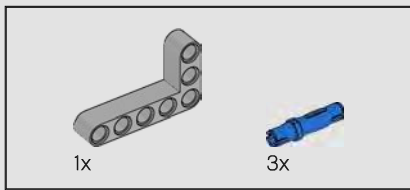

56

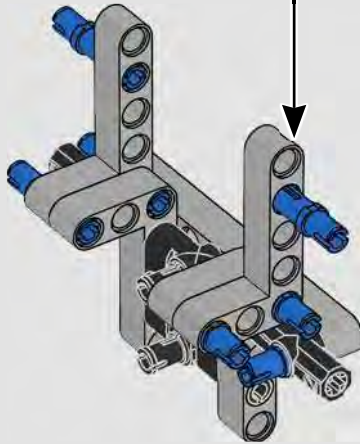
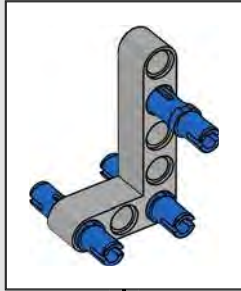

57

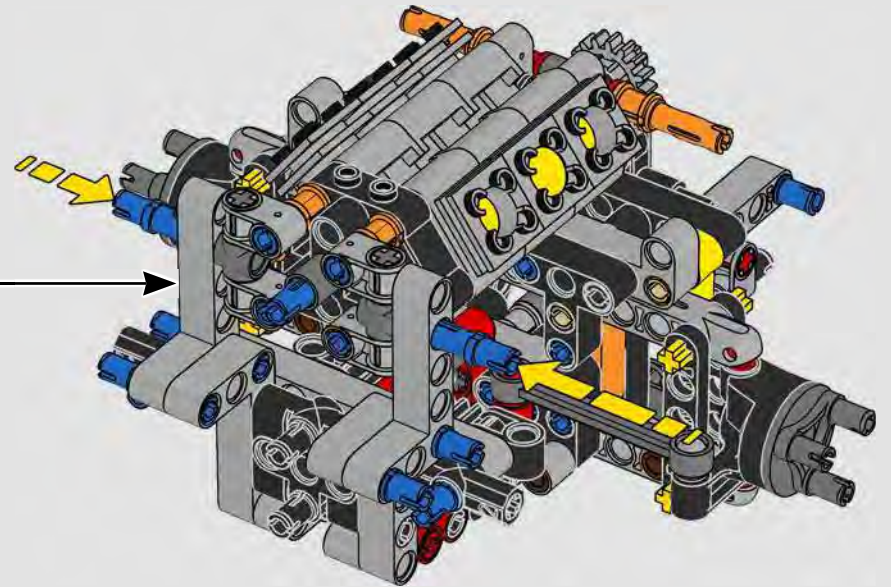

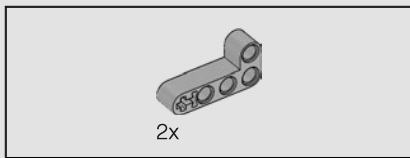

58

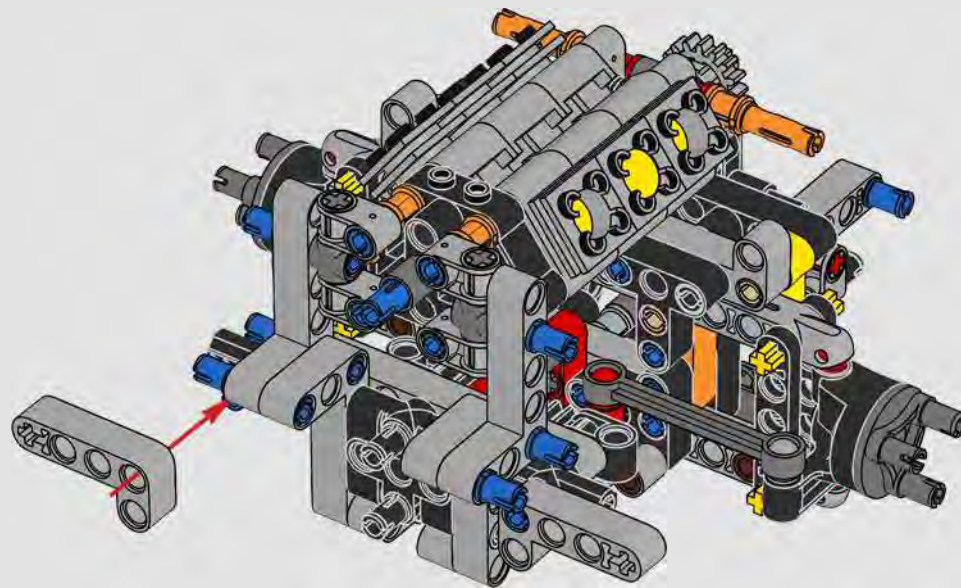

59

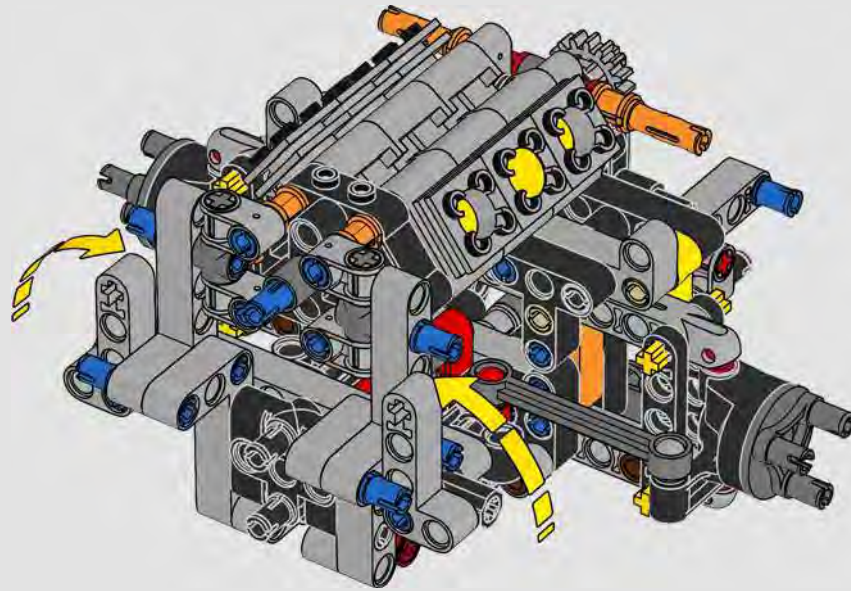

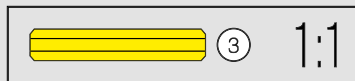
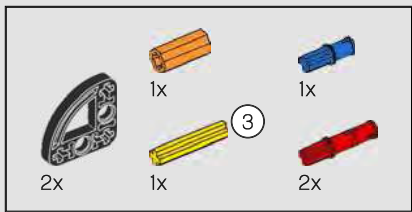

60

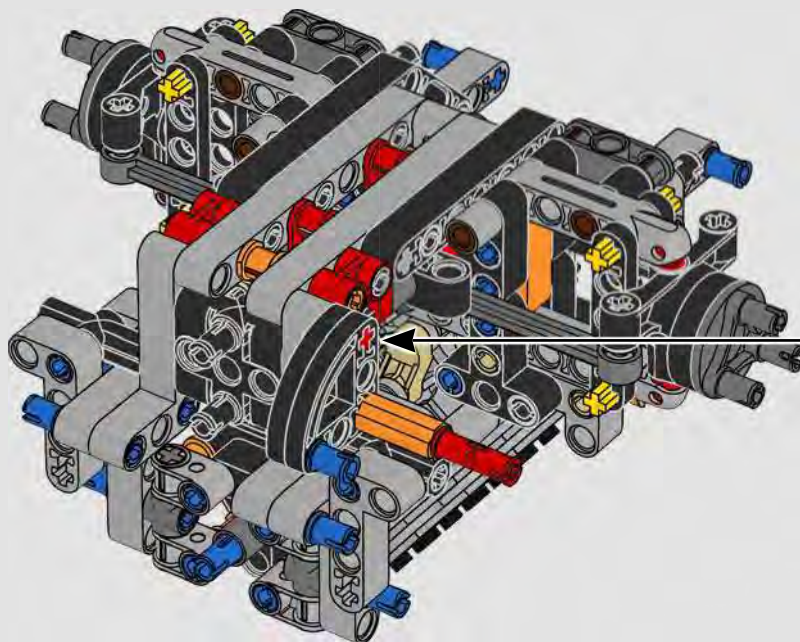
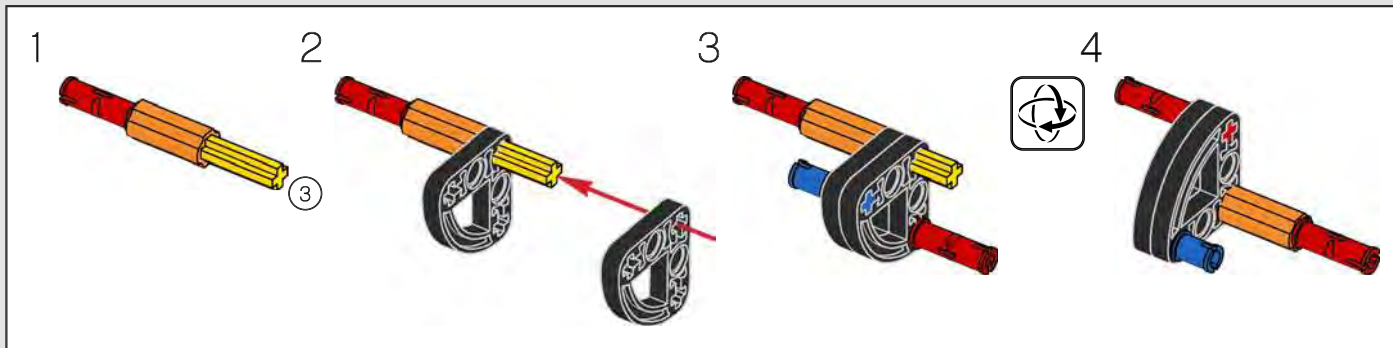

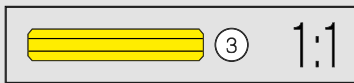
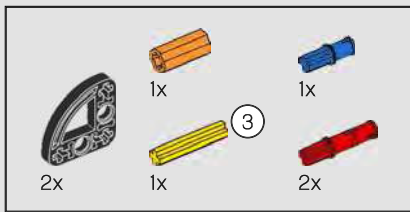

61

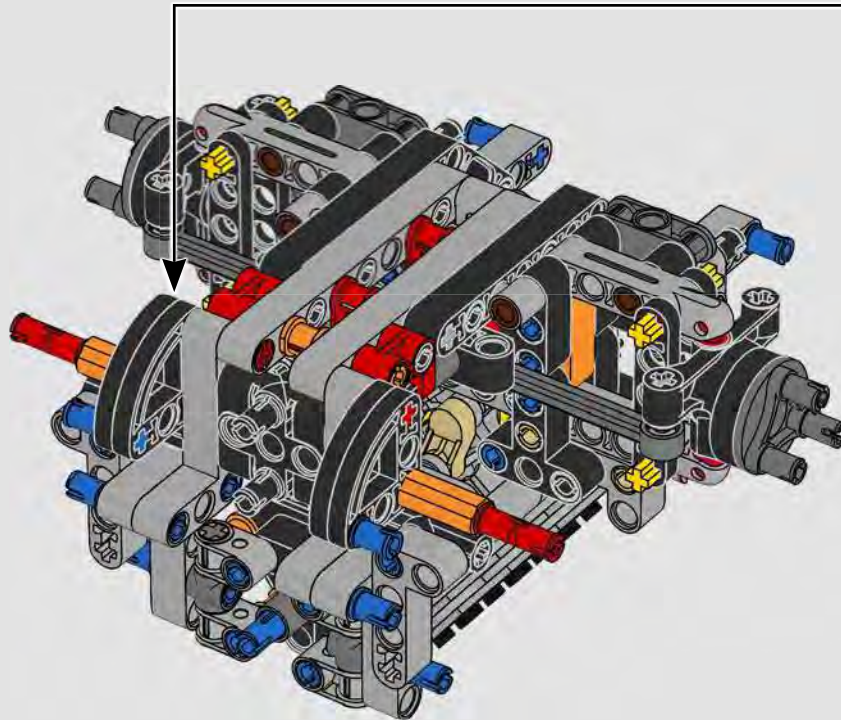
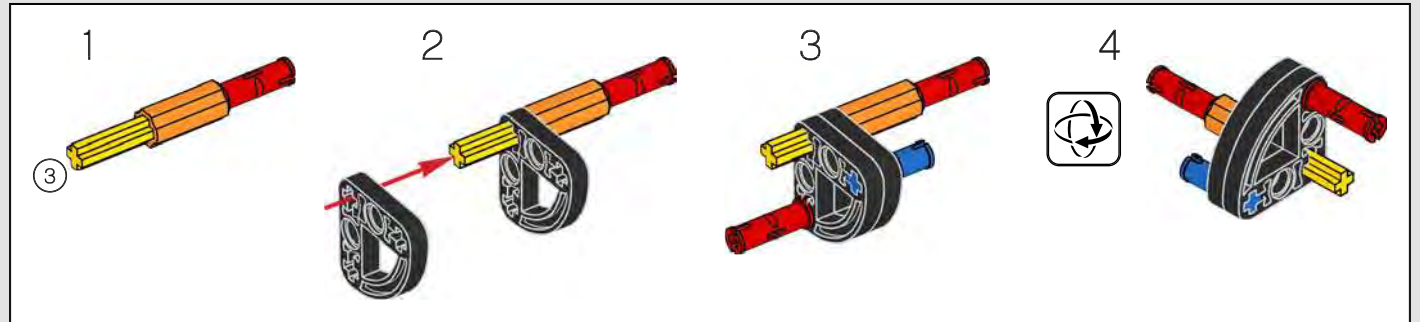

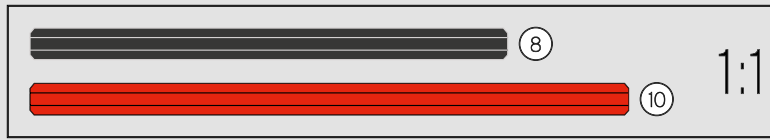
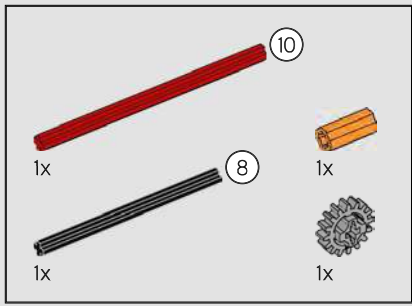

62

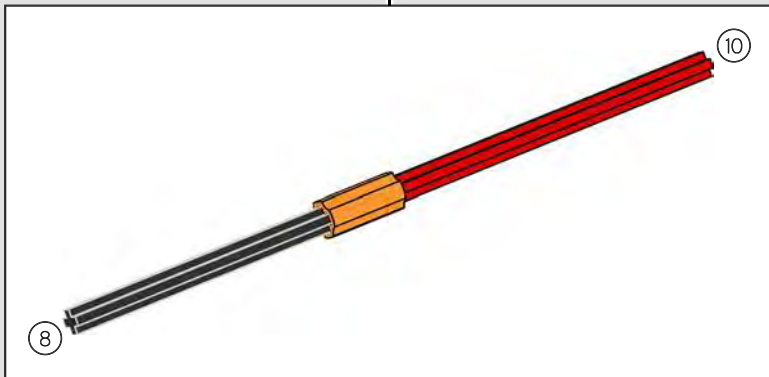
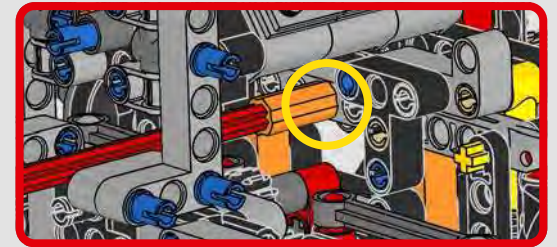
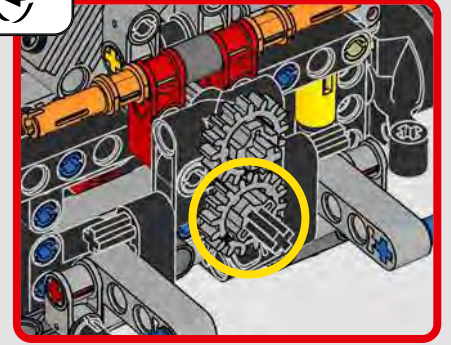
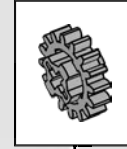
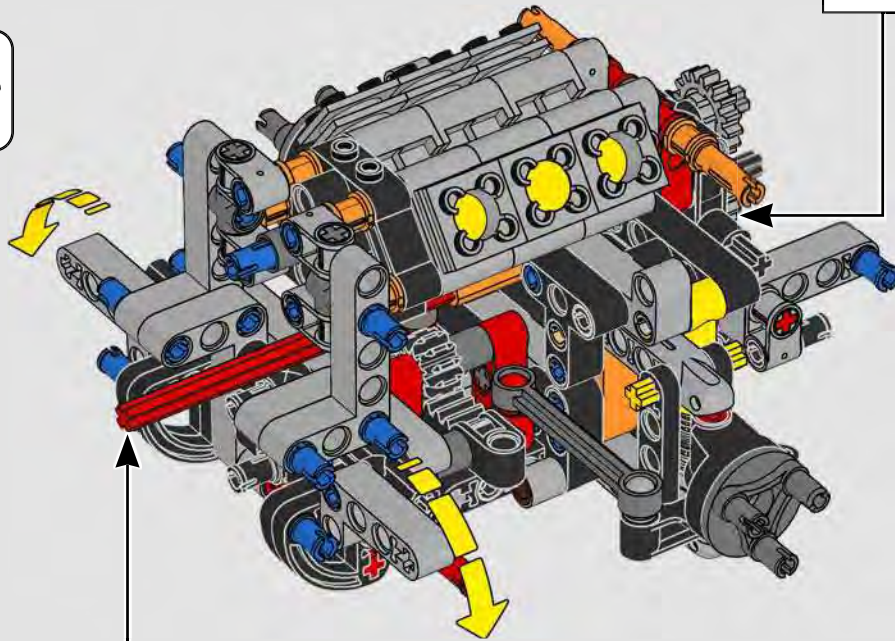

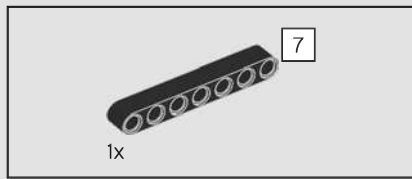

63

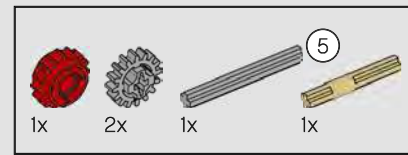
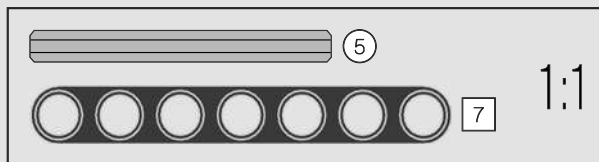
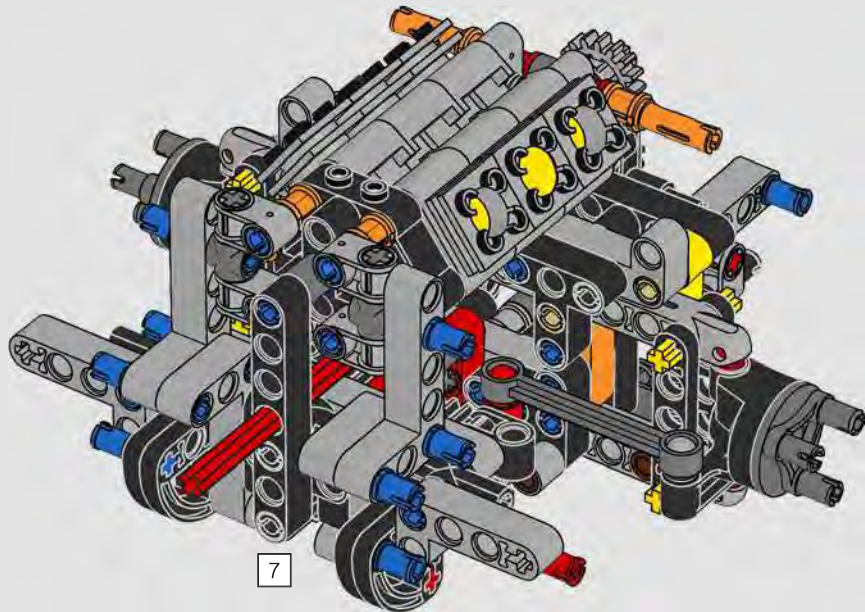

64

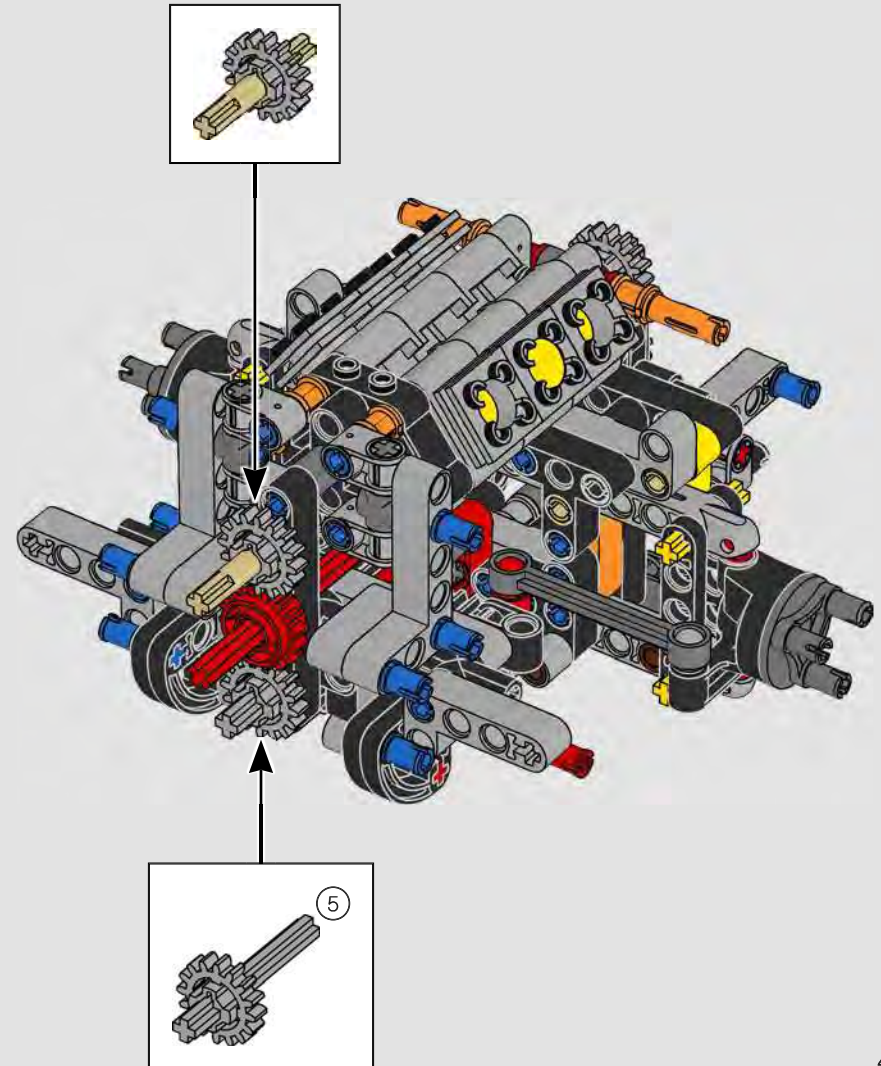

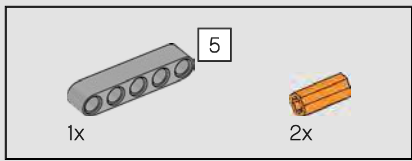

65

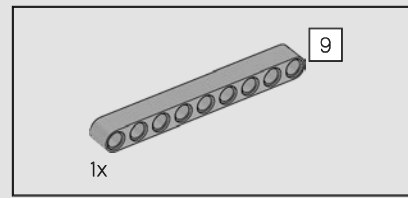
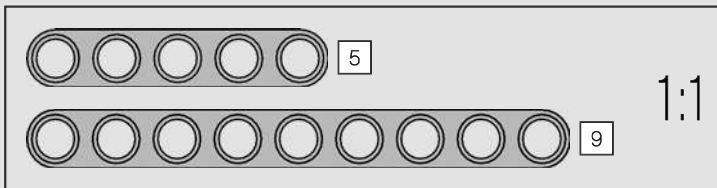
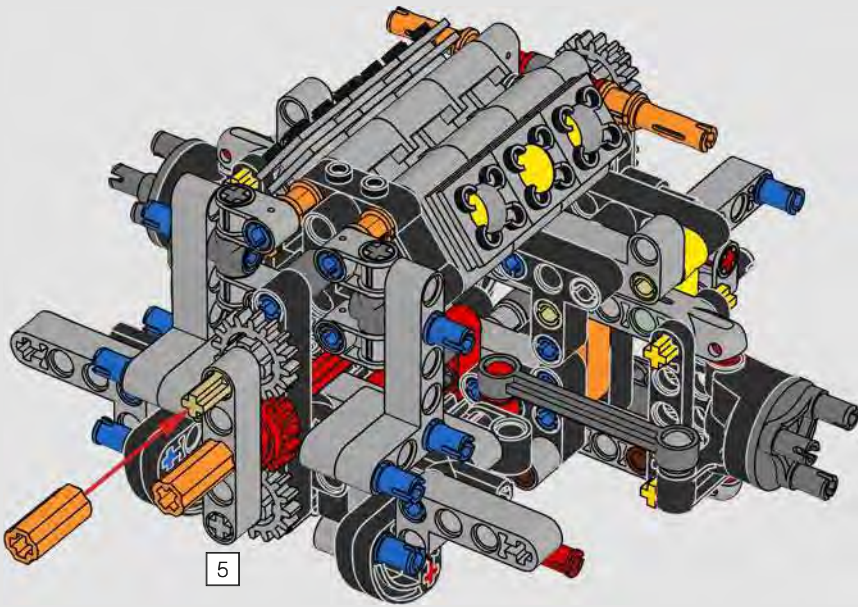

66

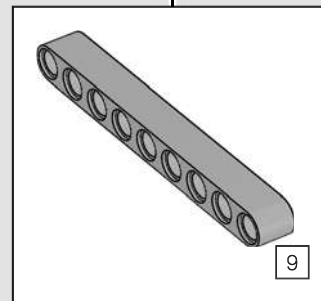
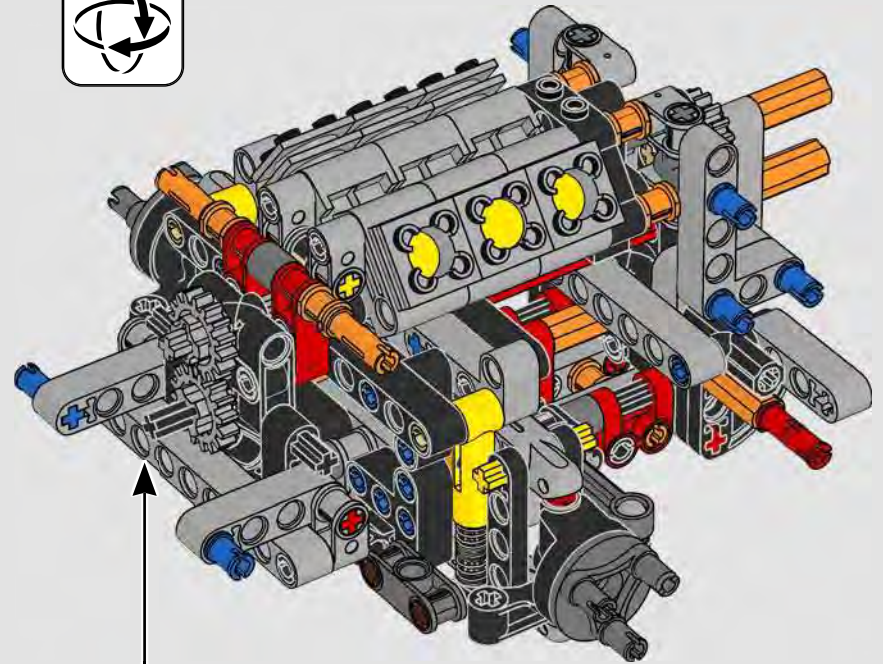
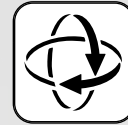



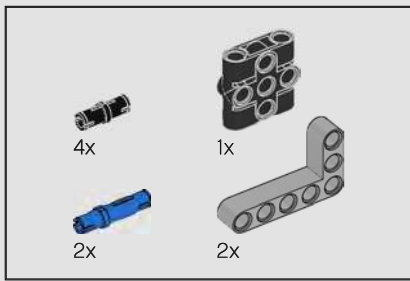

67

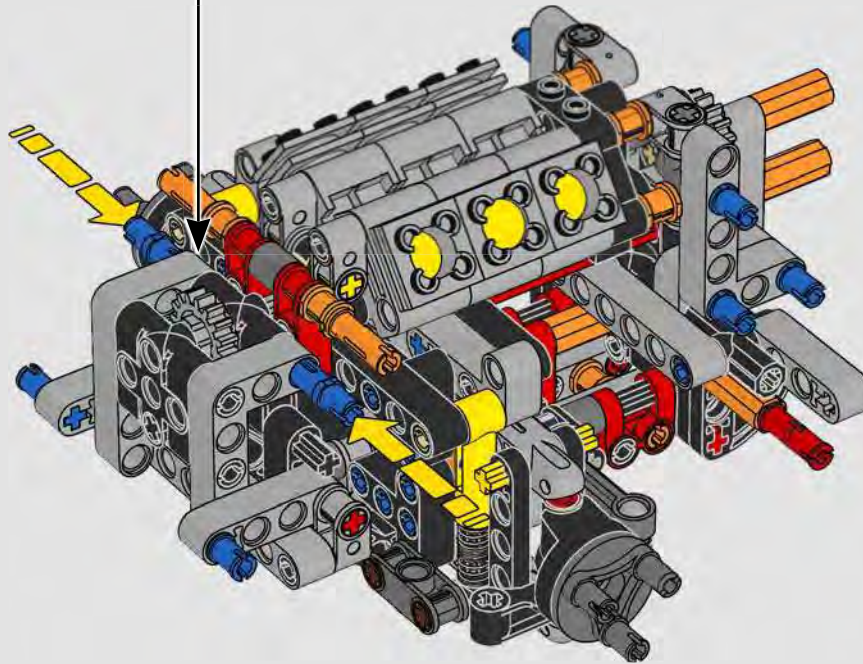
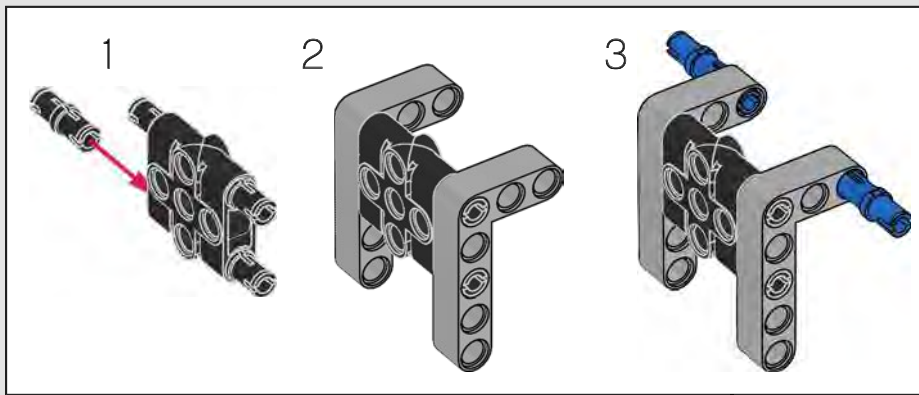

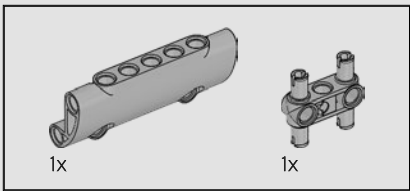

68

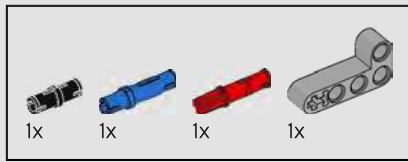
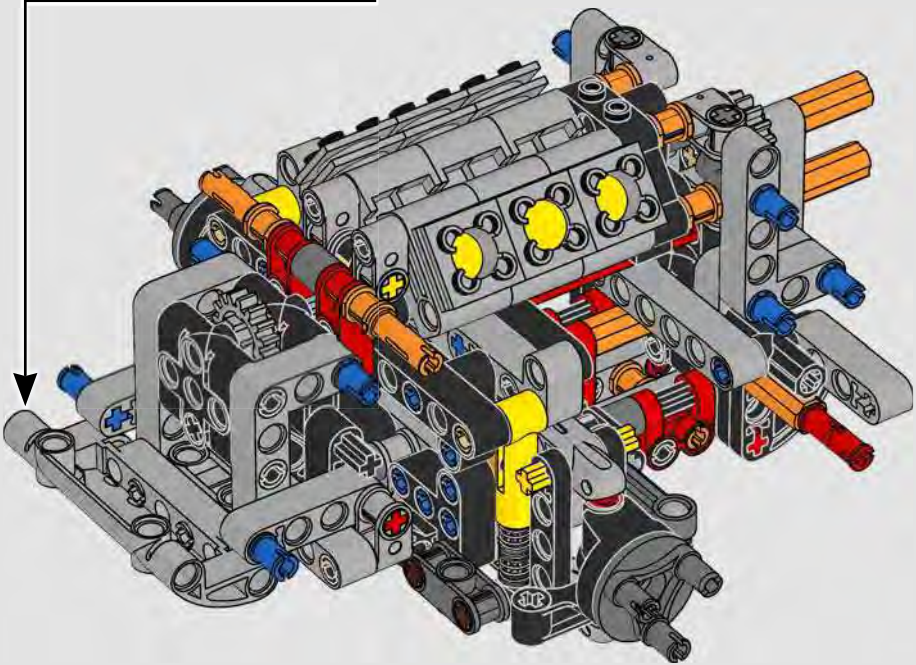
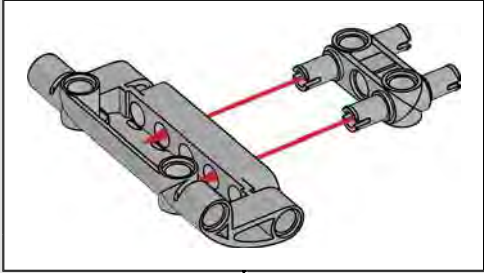

69

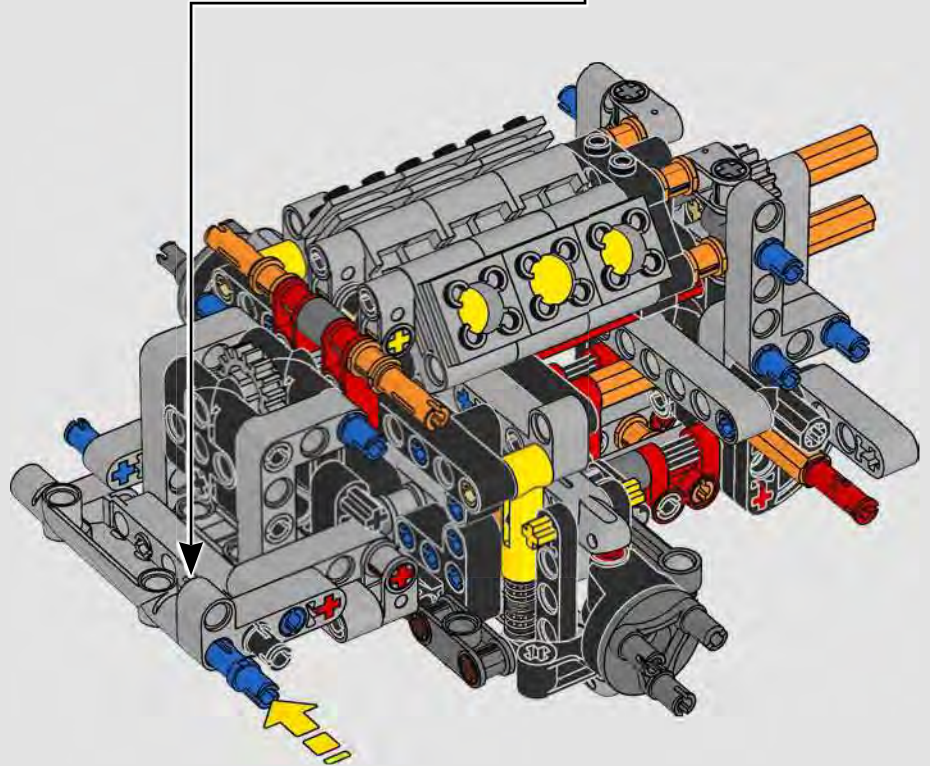
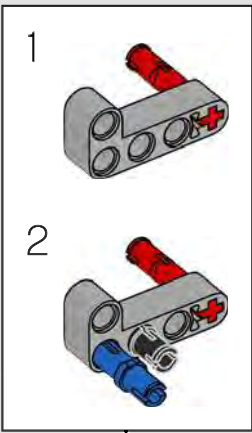

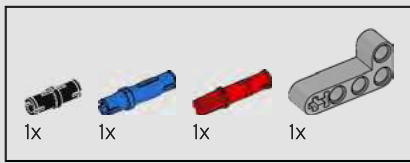

70

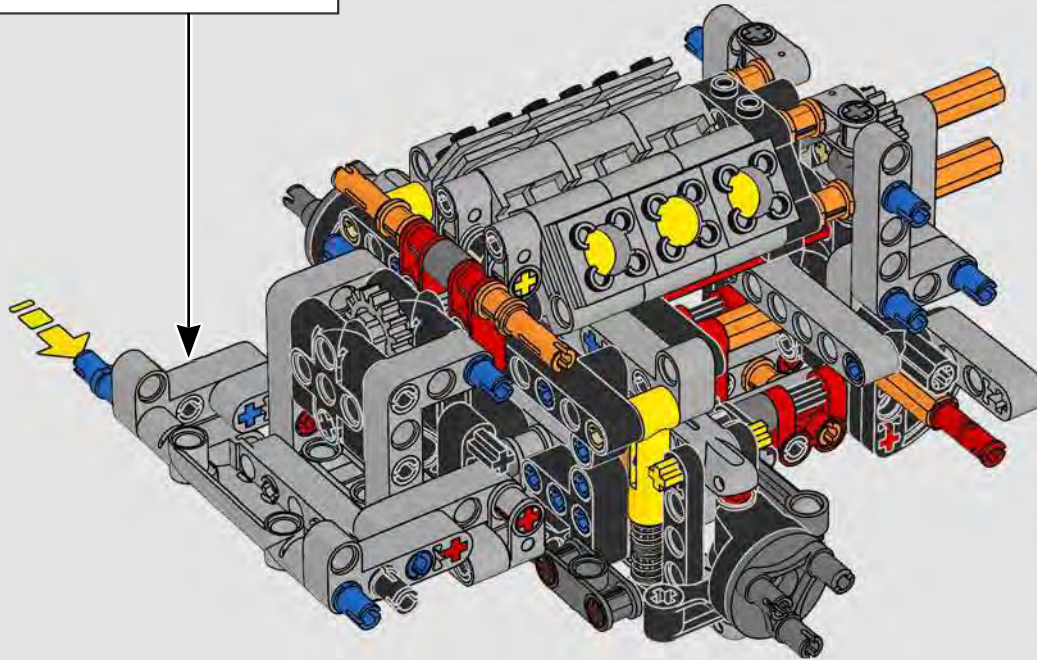
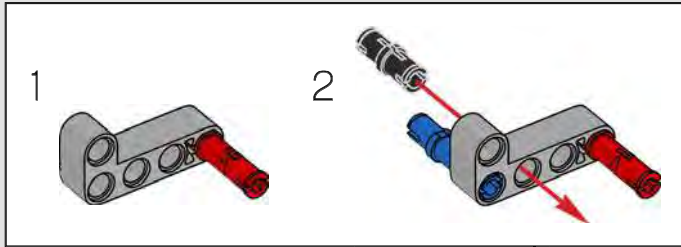

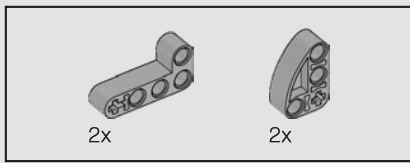

71

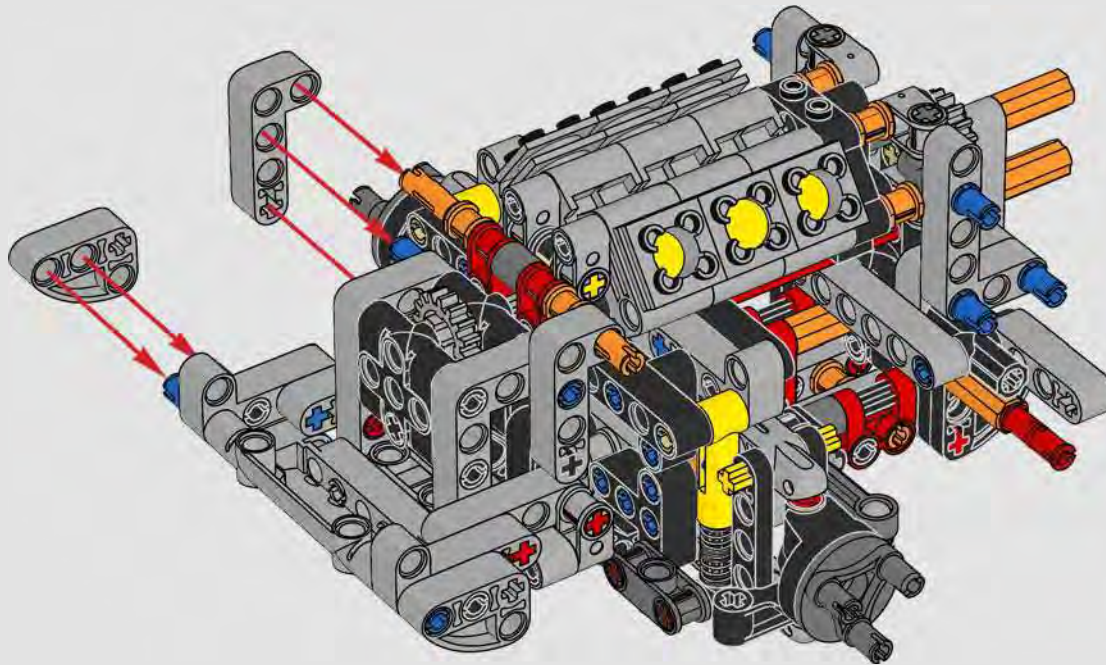

*Optimised for off-road use, the Raptor is fitted with four-wheel drive as standard.*

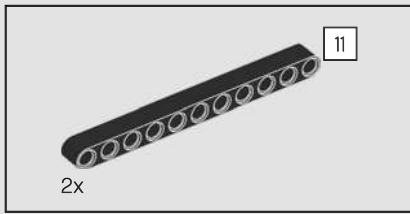

72

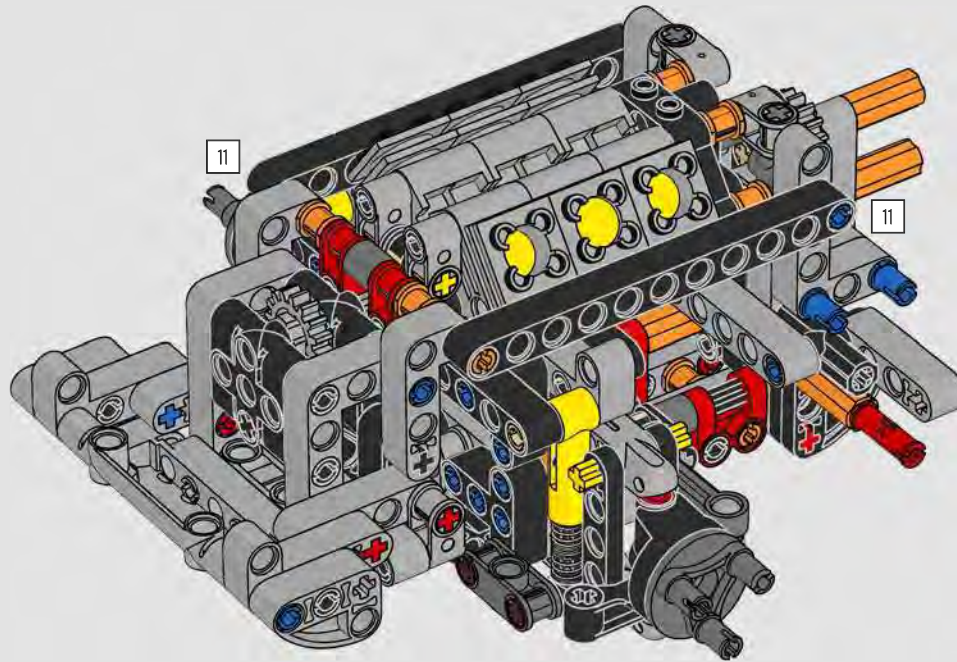

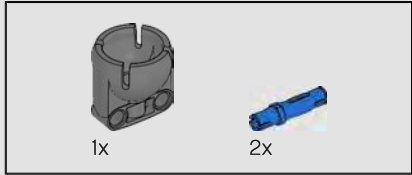
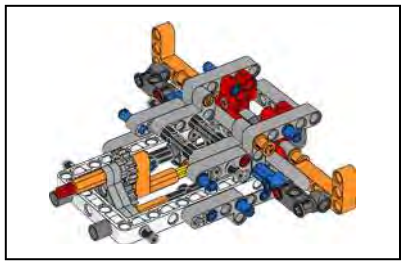

73

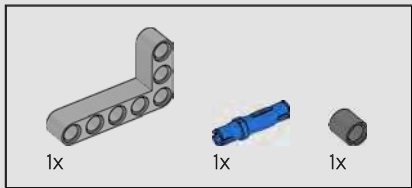
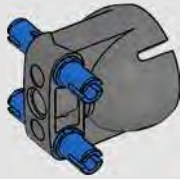

74

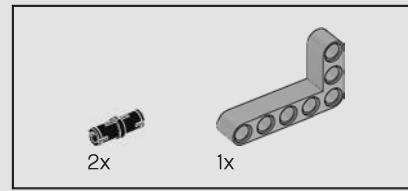
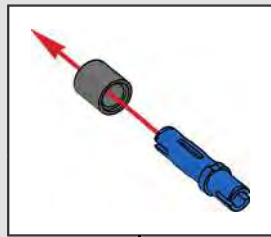
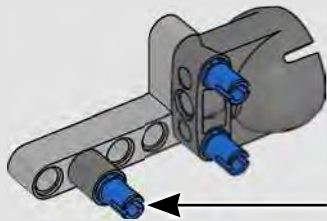

75

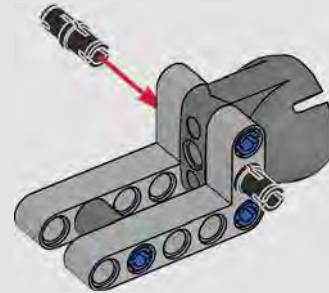

76

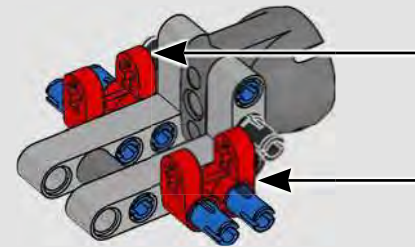
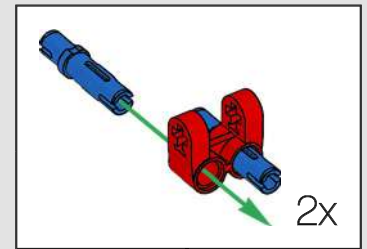

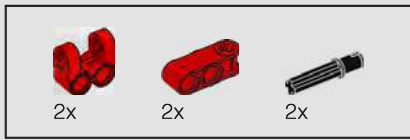

77

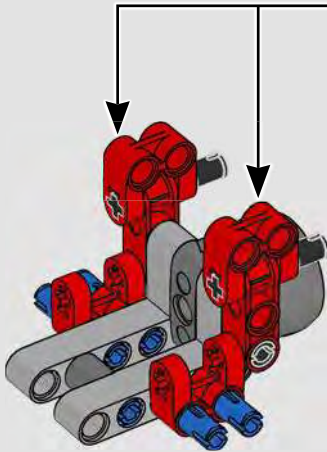
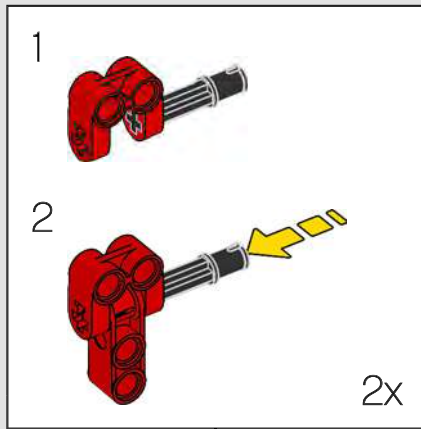

78

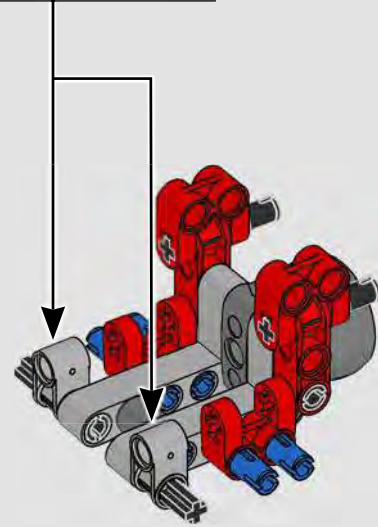
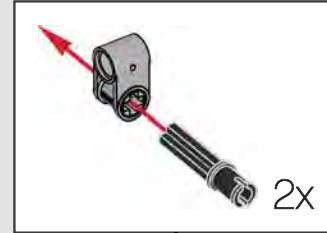

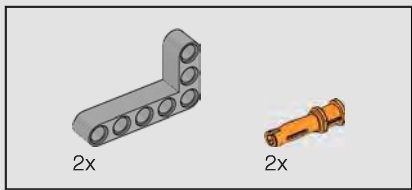

79

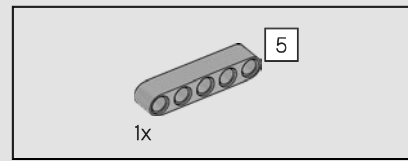
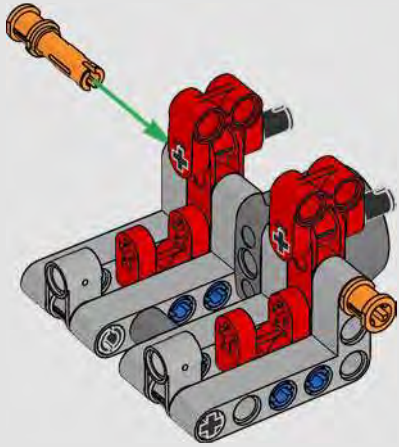

80

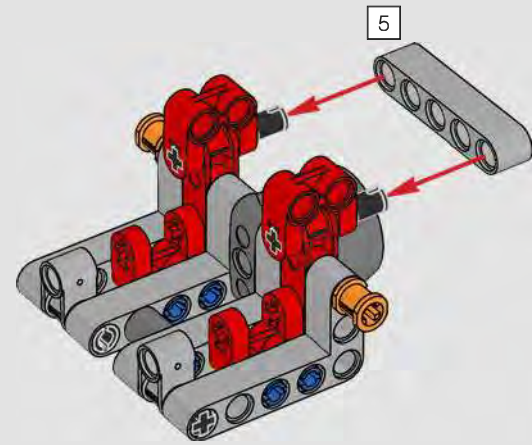
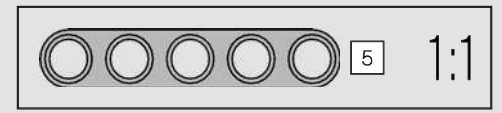



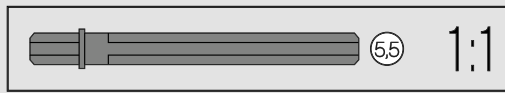
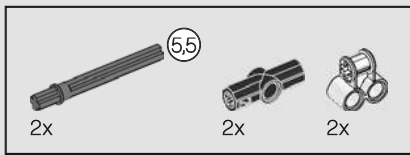

81

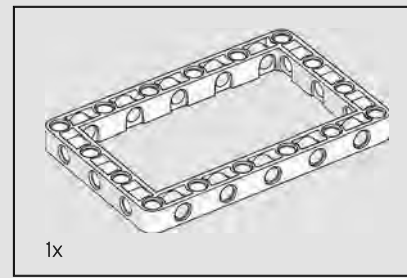
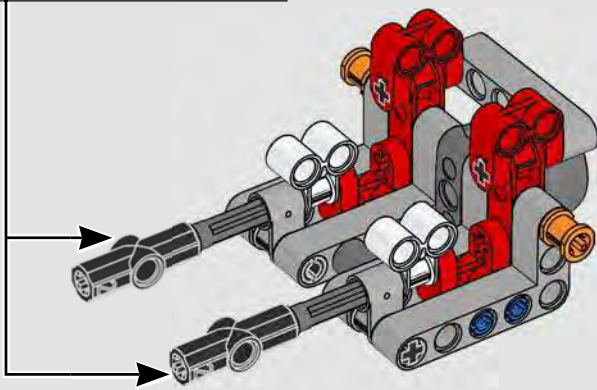
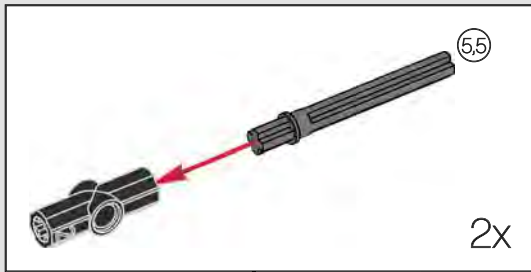

82

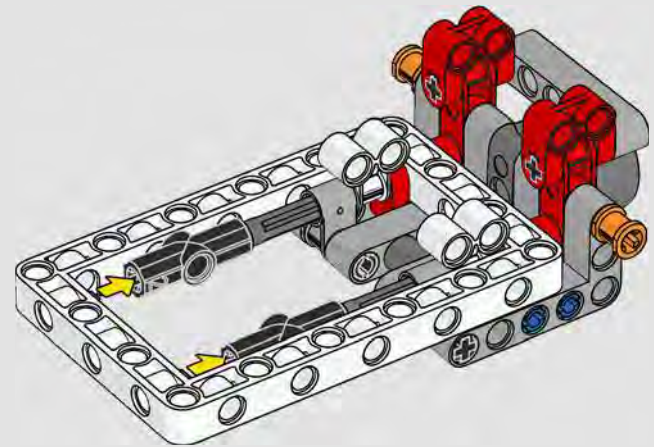

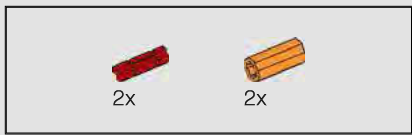

83

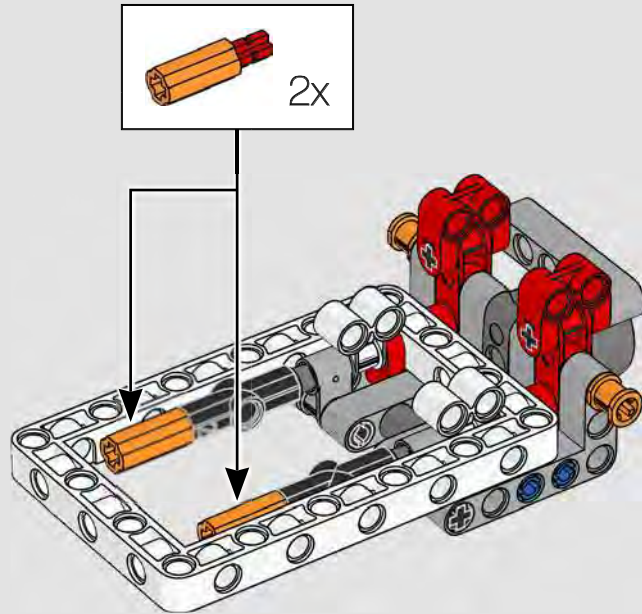

84

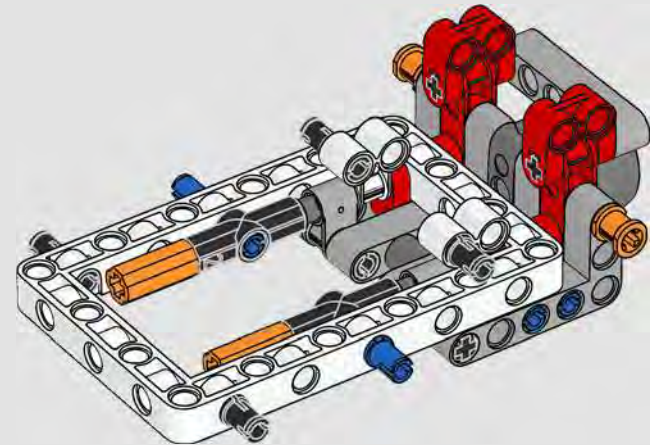

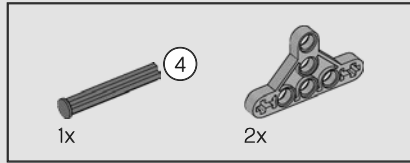
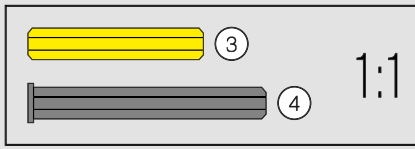
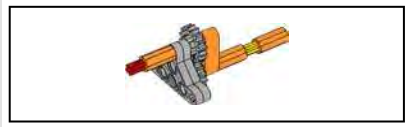

85

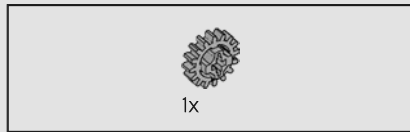
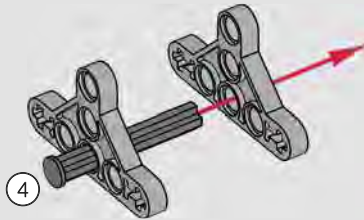

86

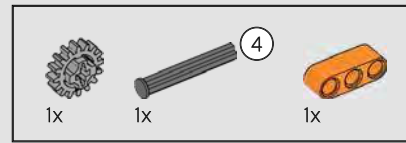
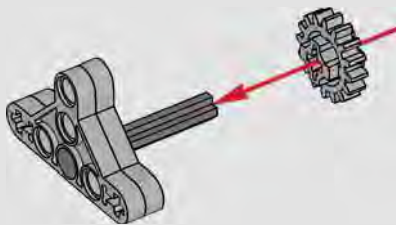

87

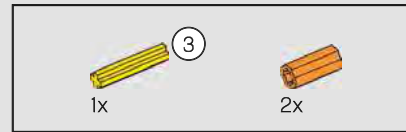
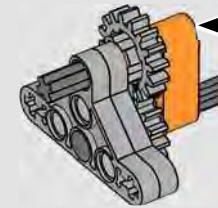
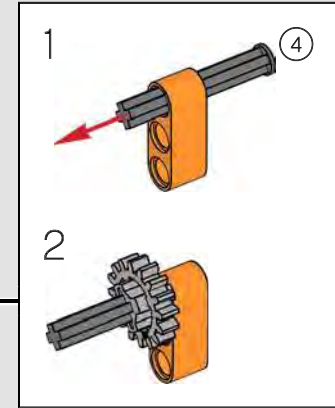

88

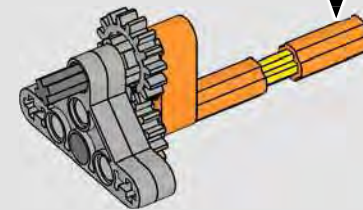
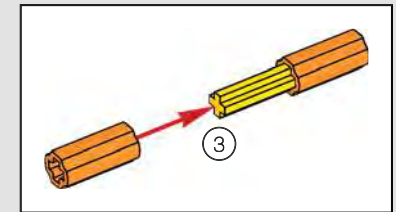

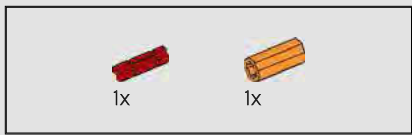

89

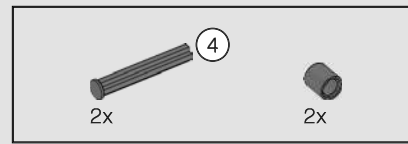
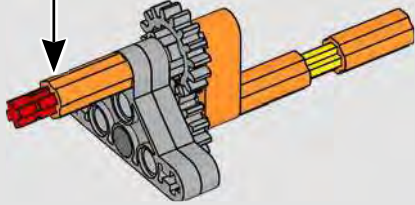
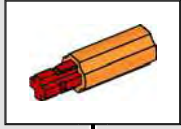

91

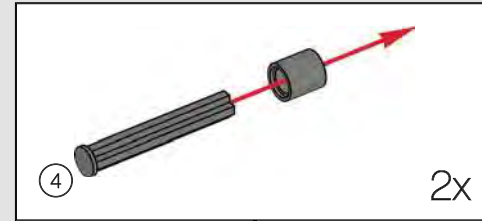
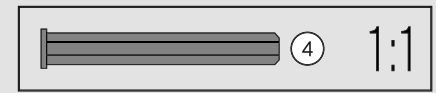

90

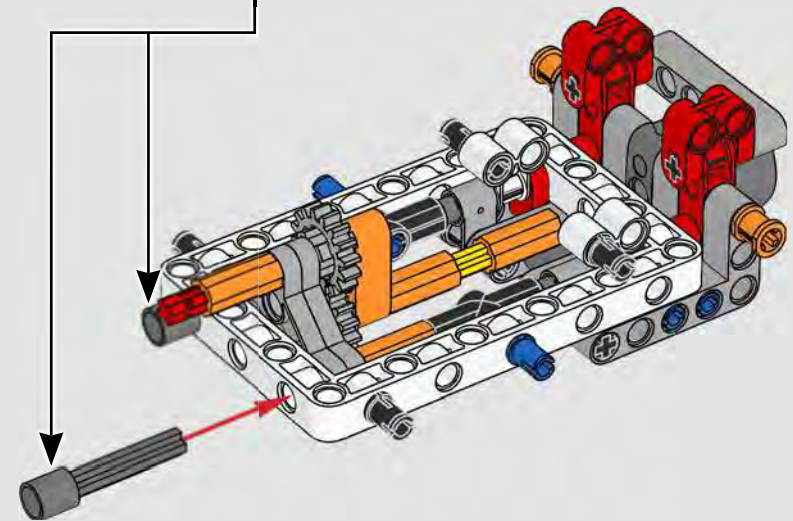
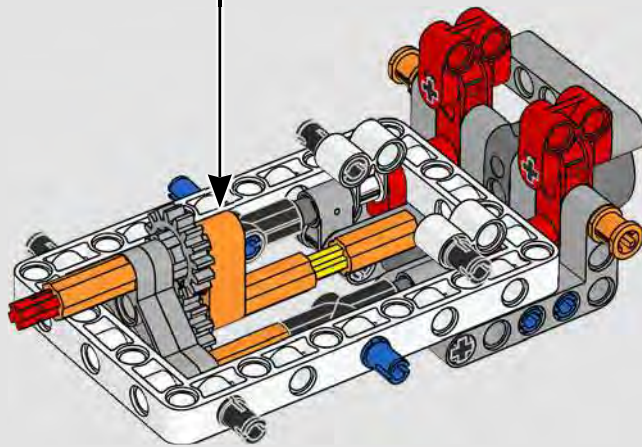

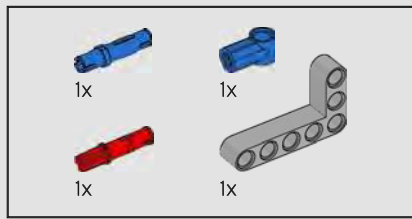

92

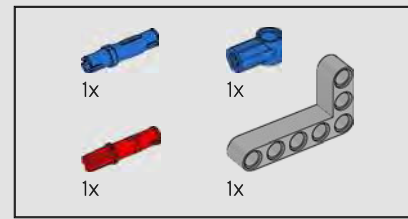
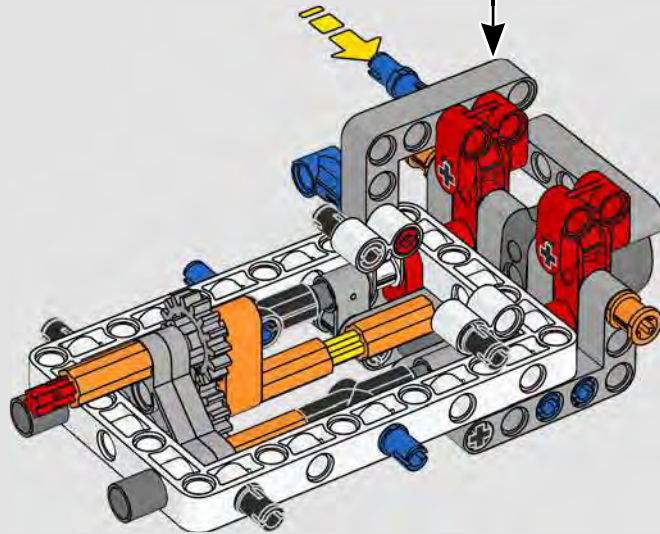
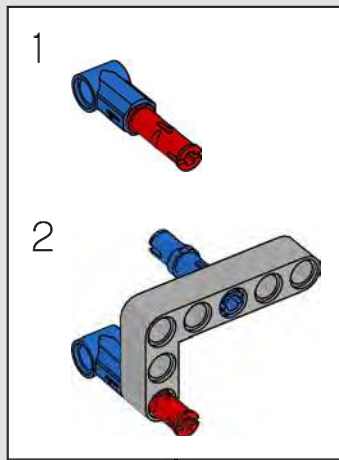

93

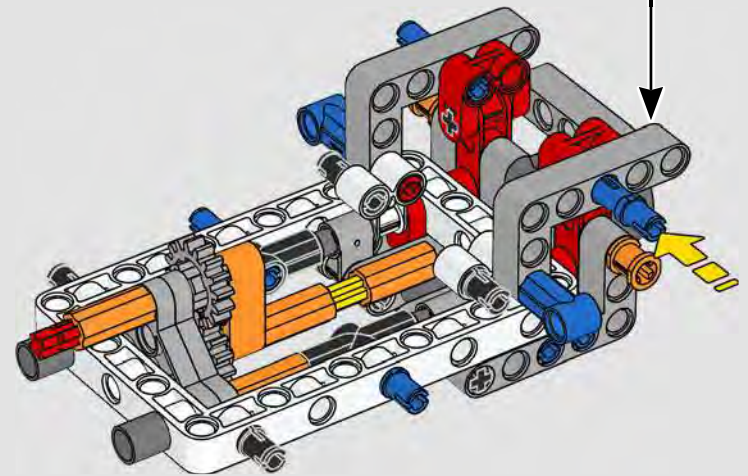
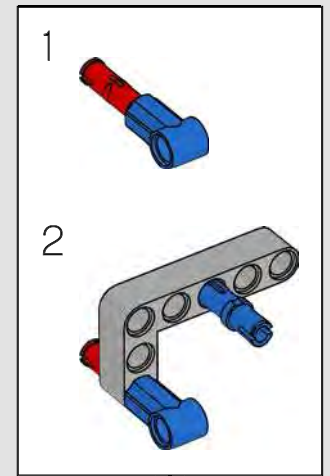

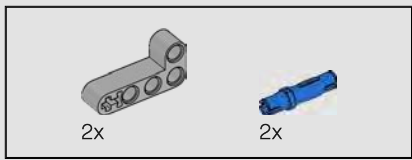

94

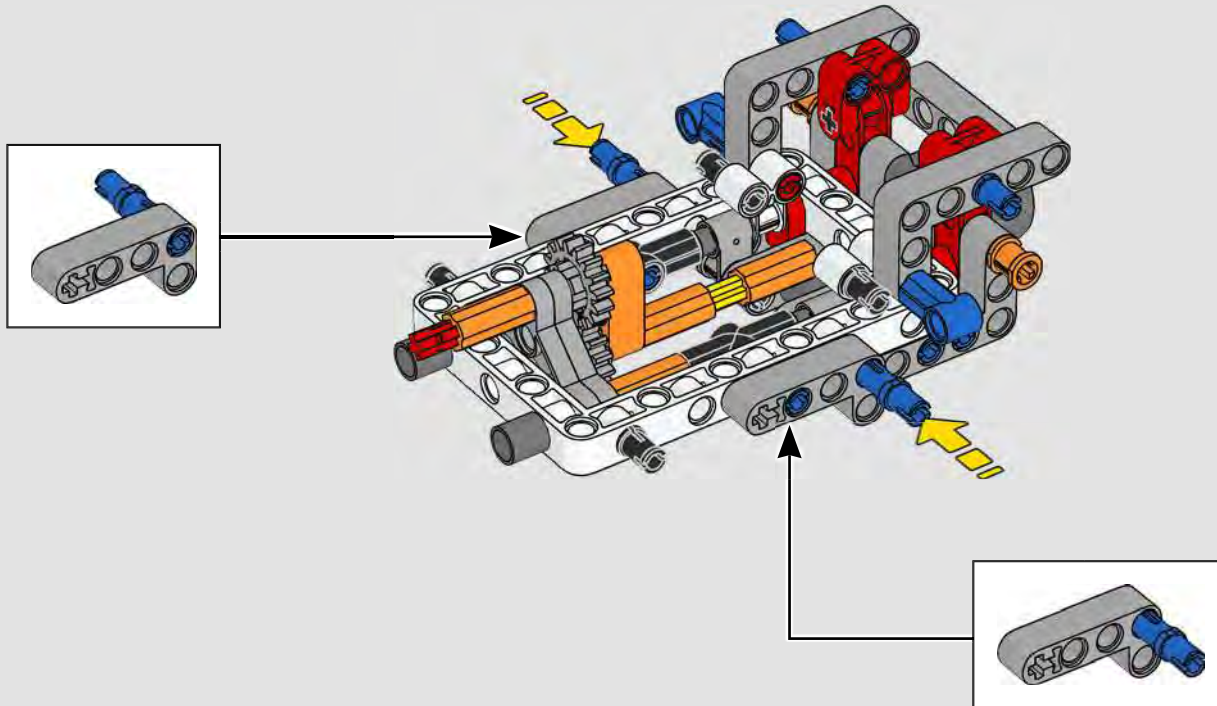

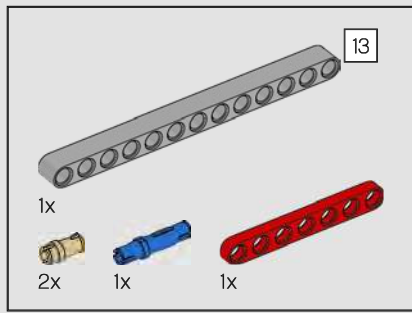

95

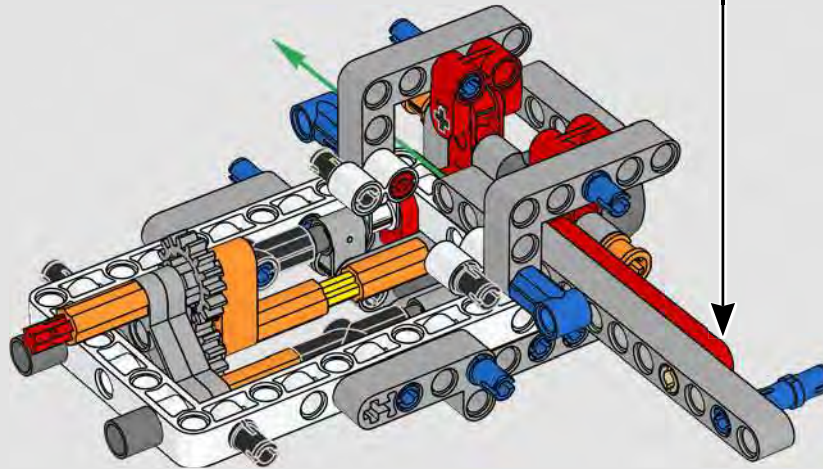
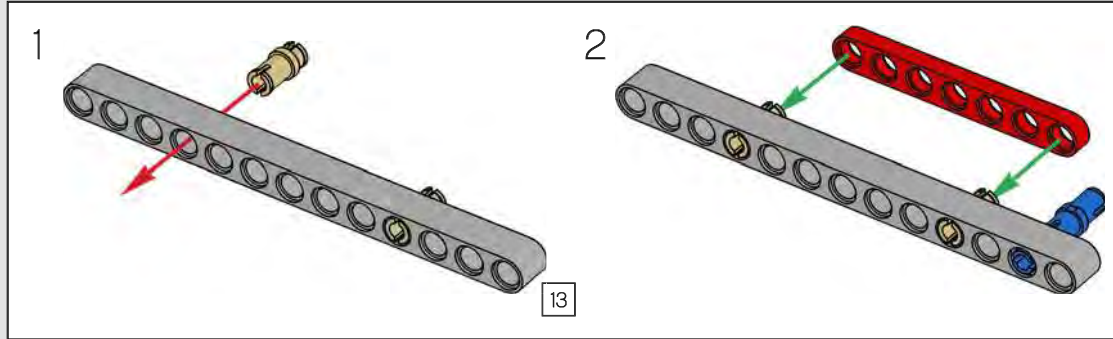
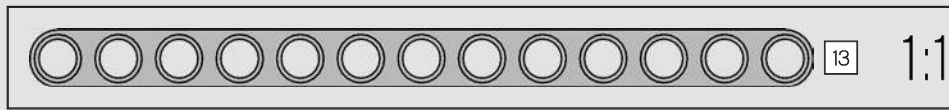

96

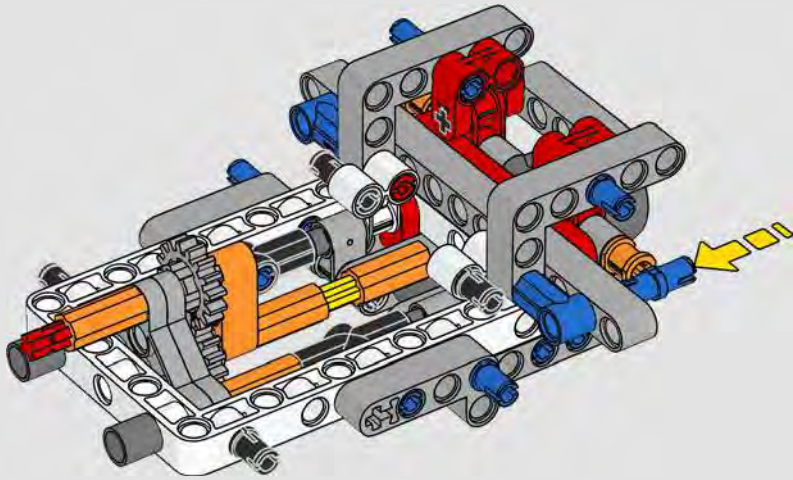

97

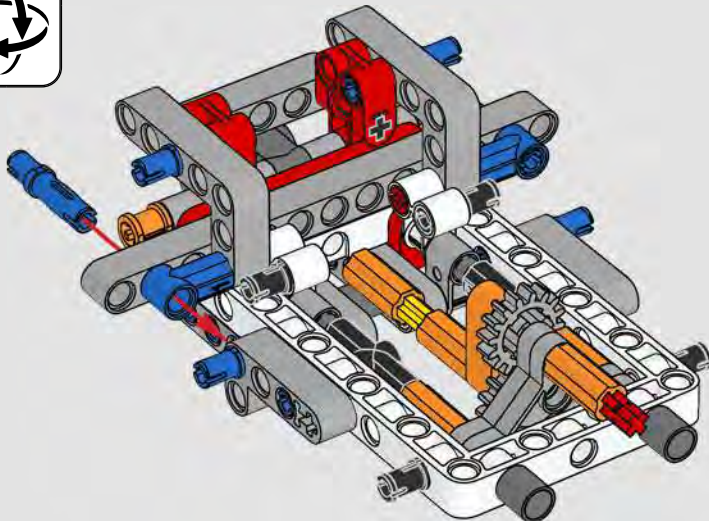

98

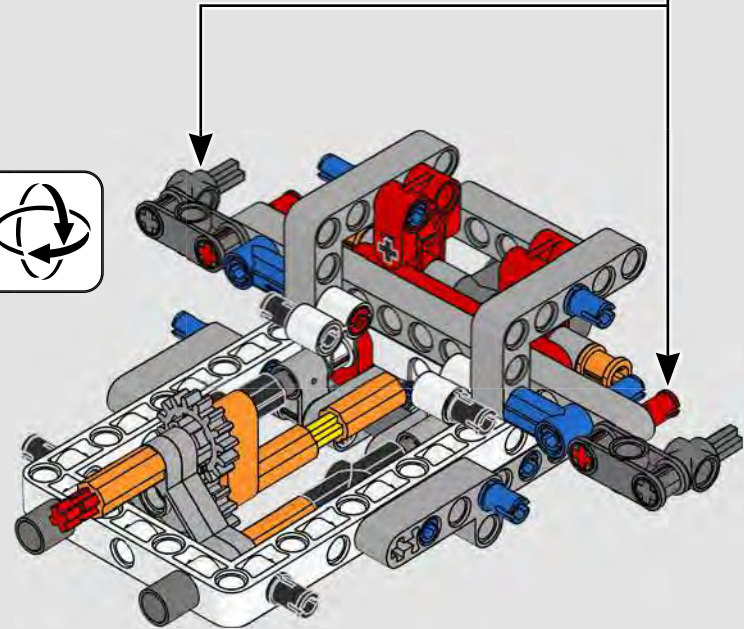
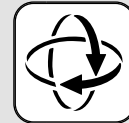
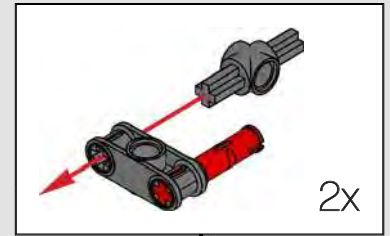



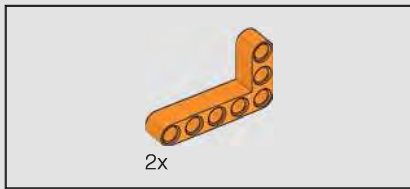

99

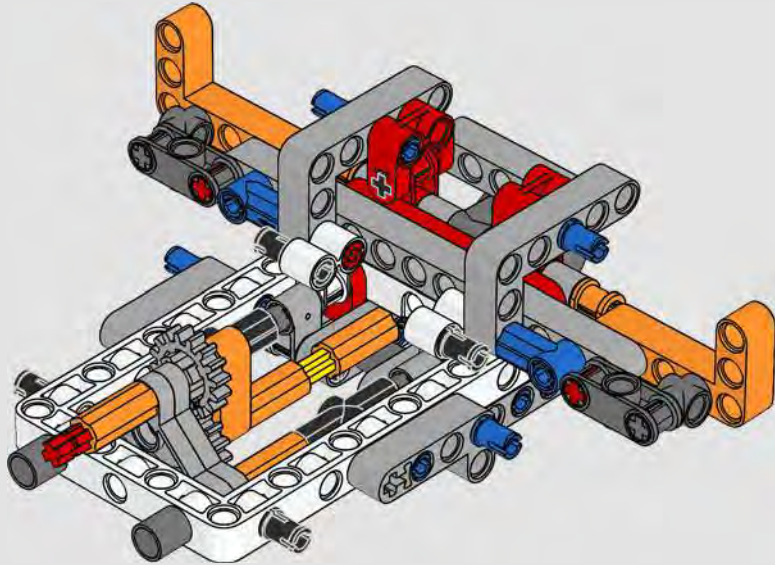

100

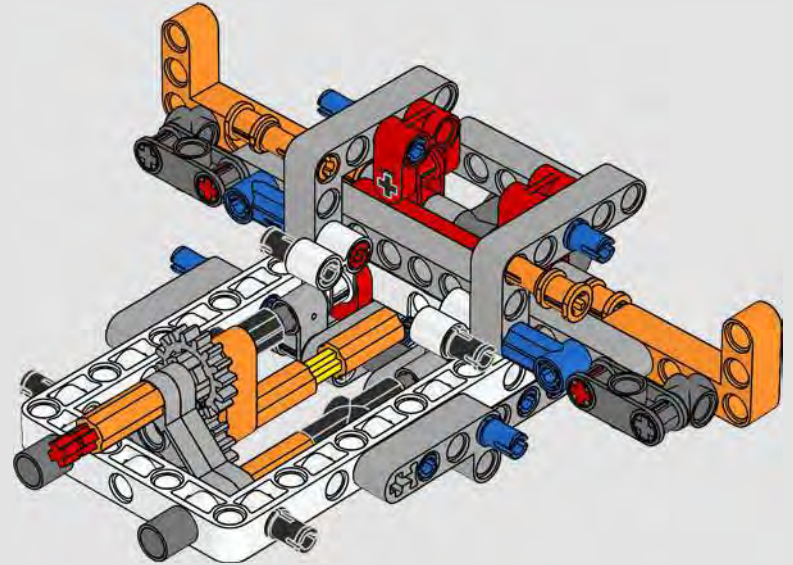

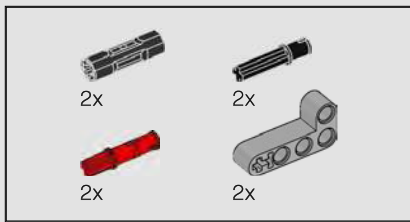

101

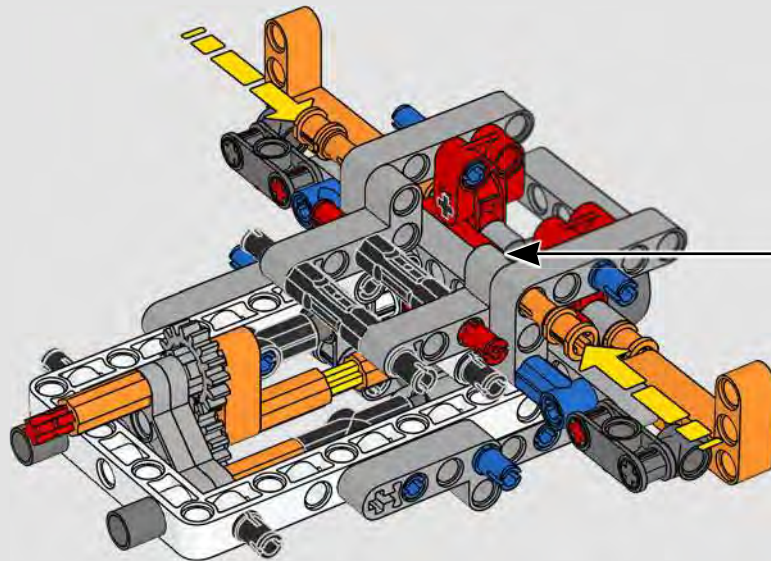
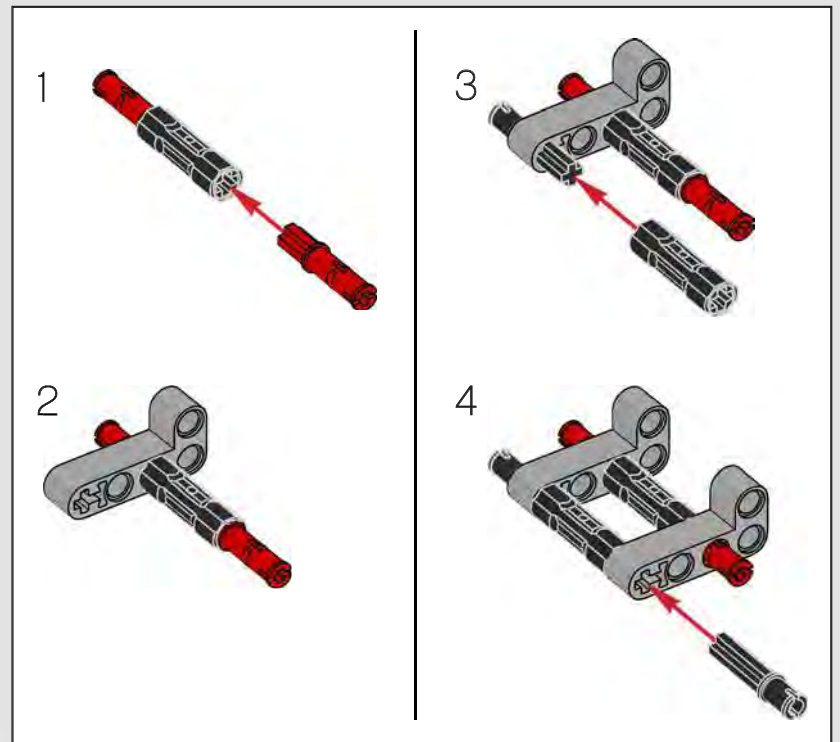

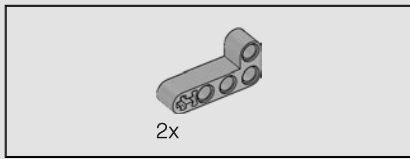

102

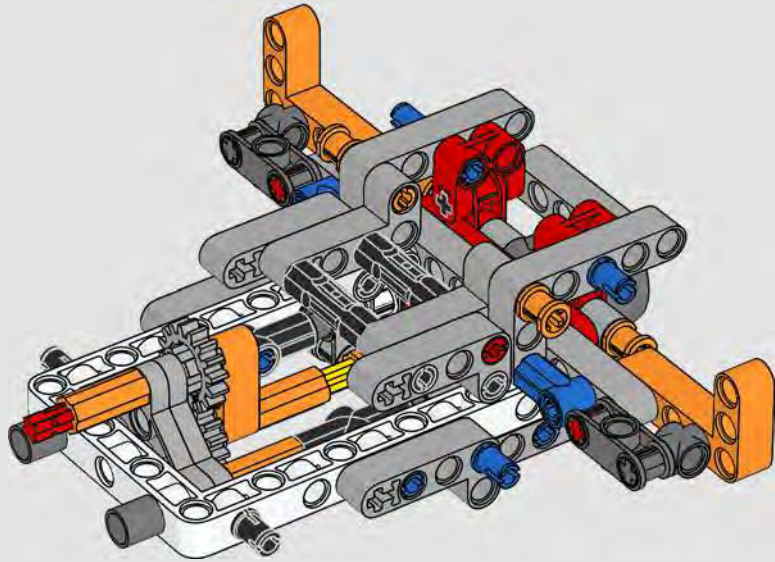

103

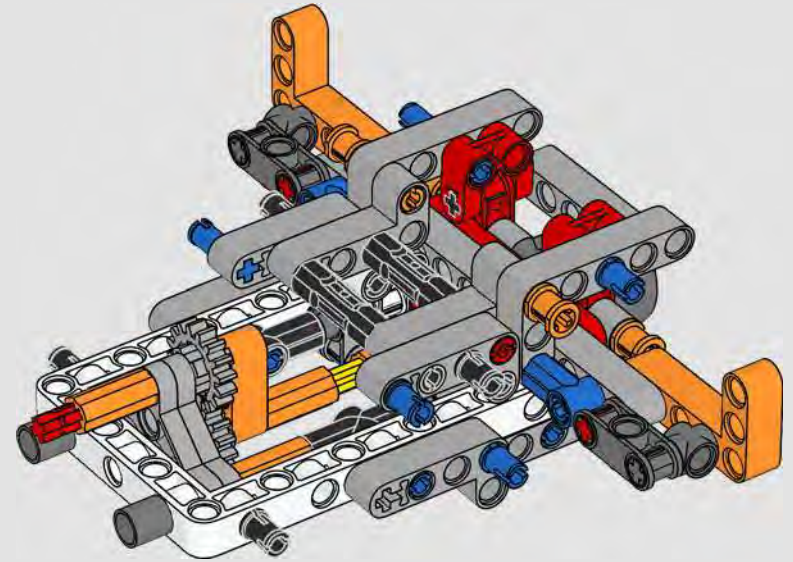

104

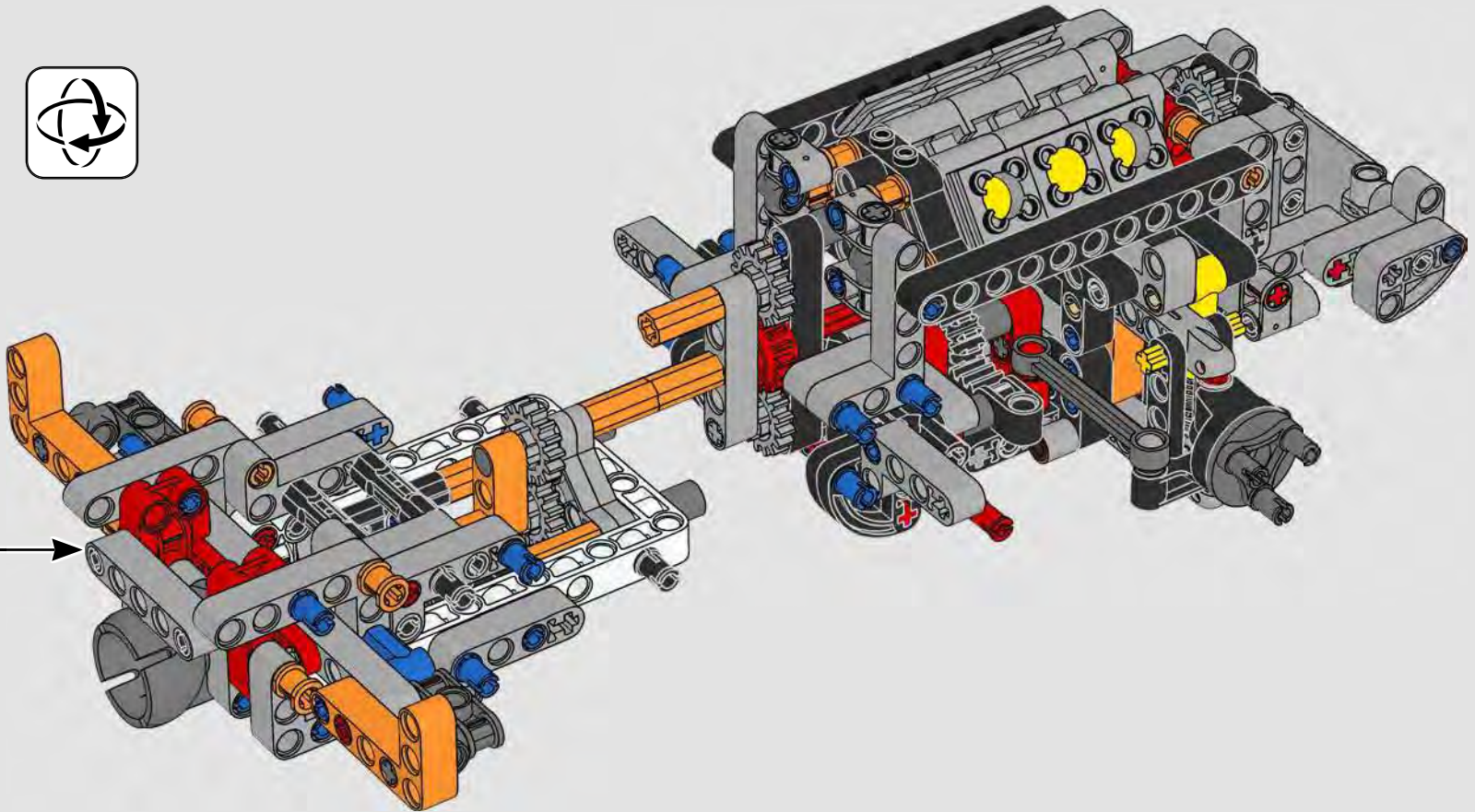

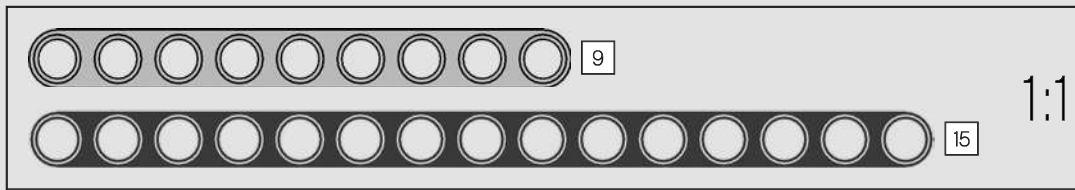
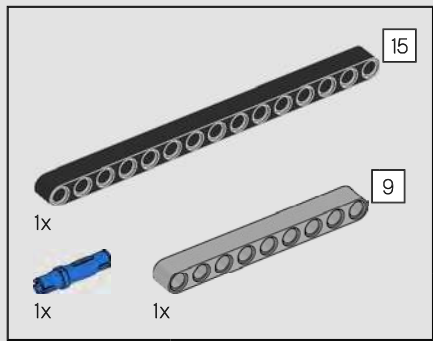

105

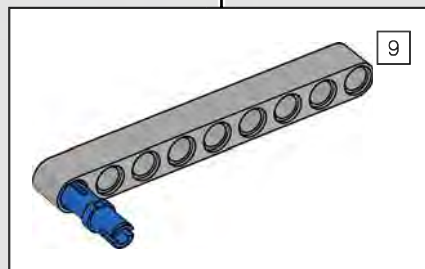
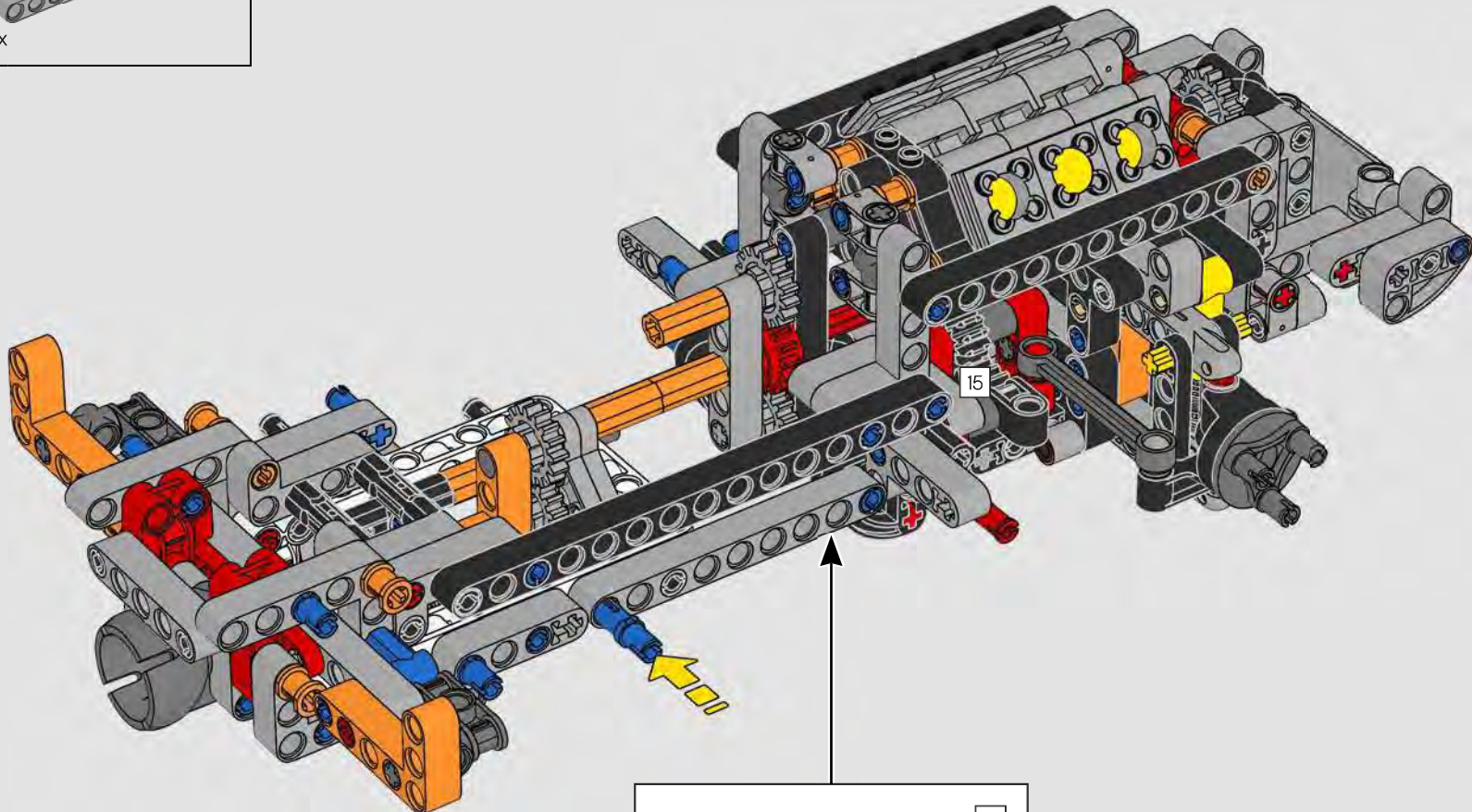

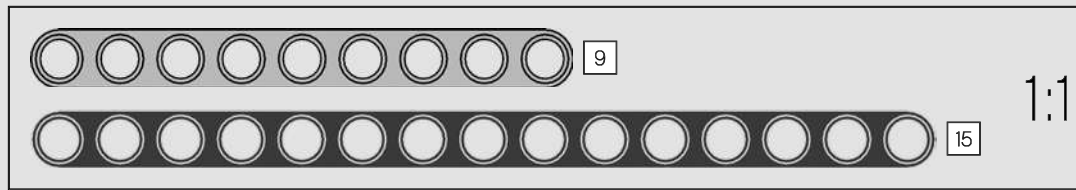
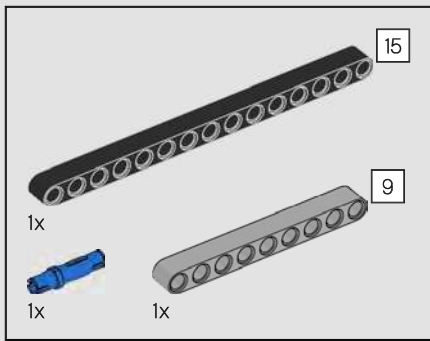

106

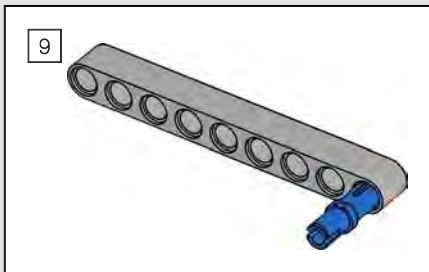
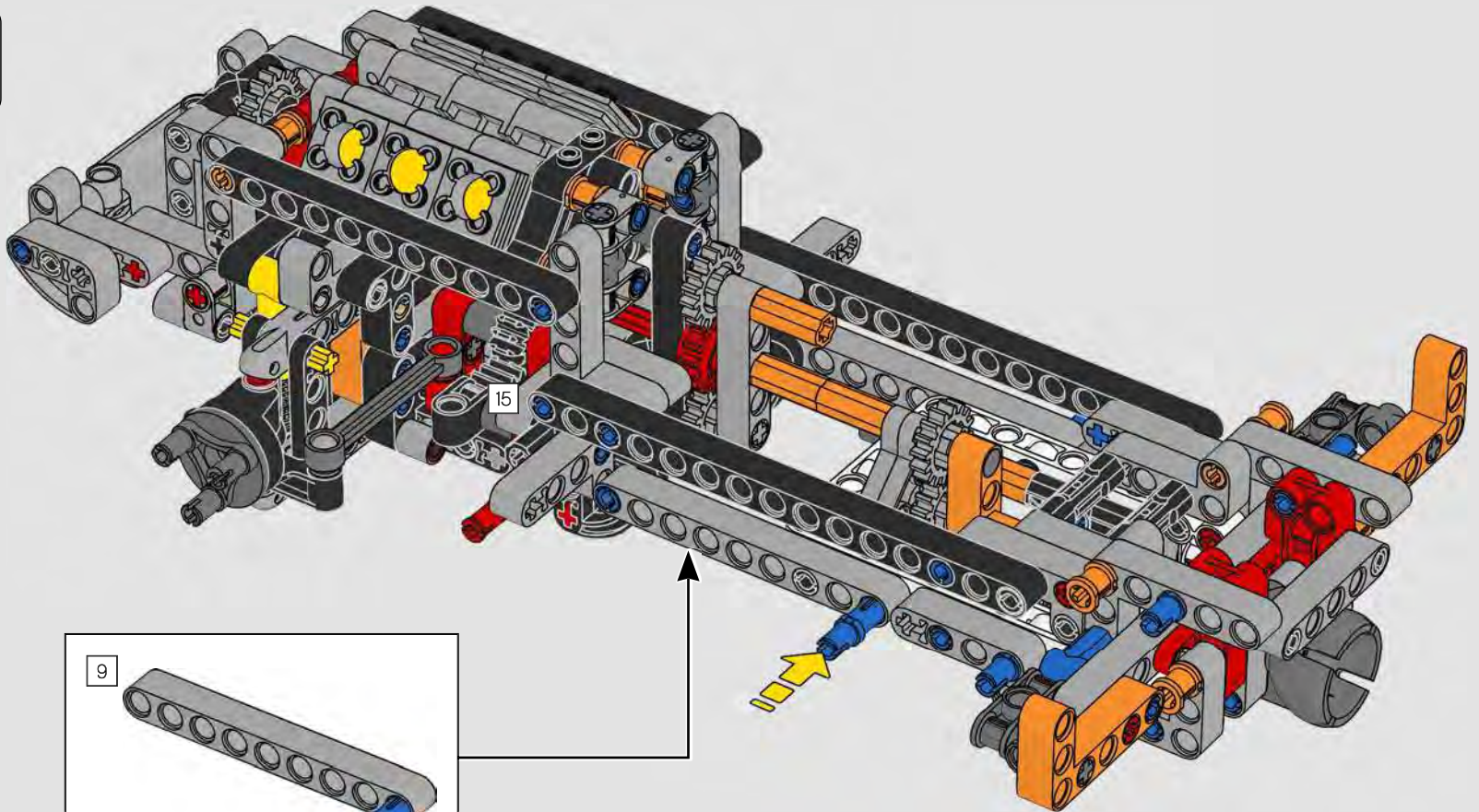

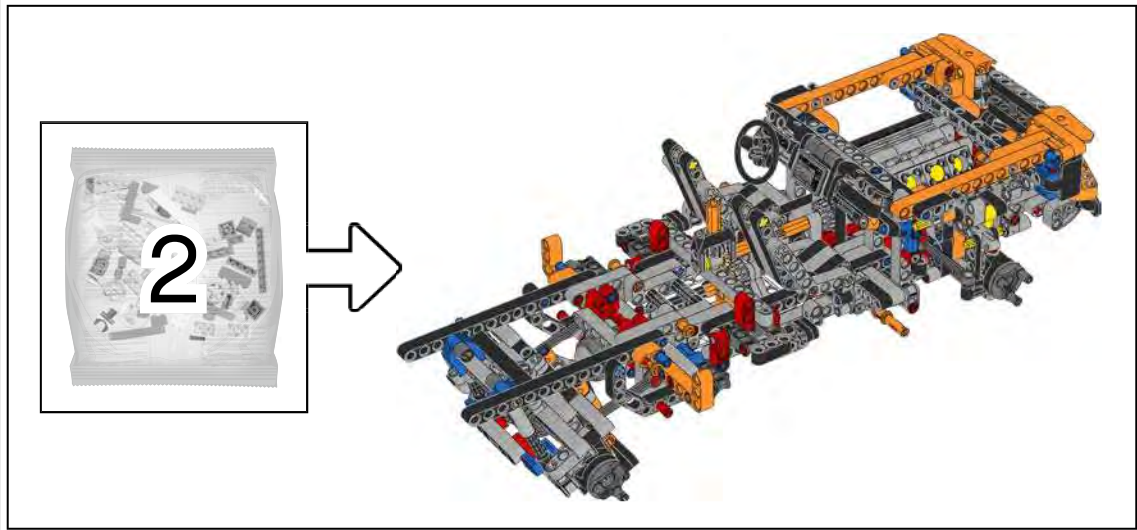

107

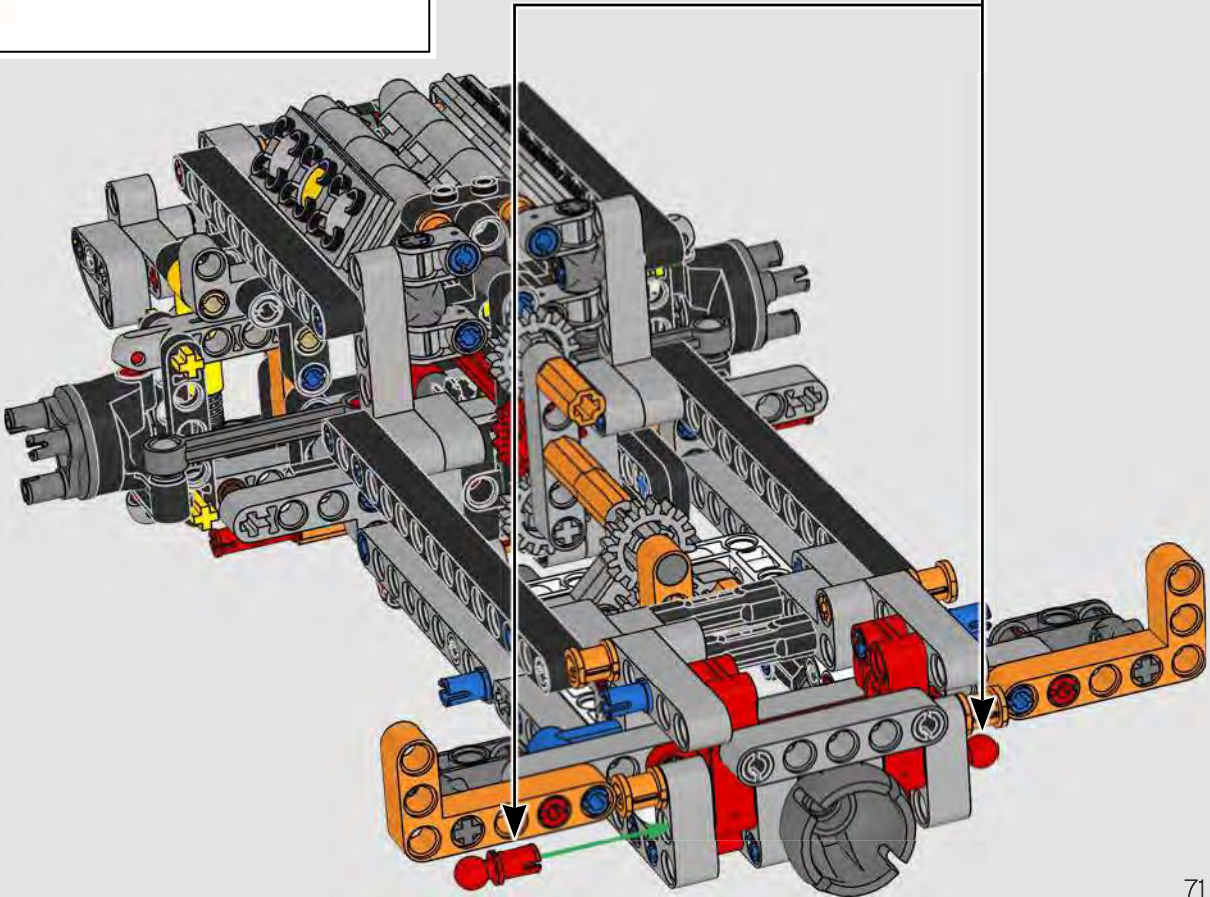

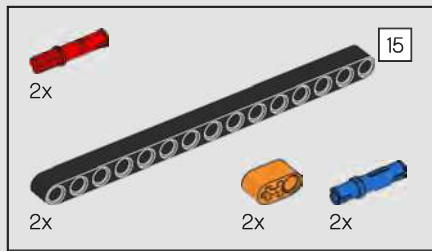

108

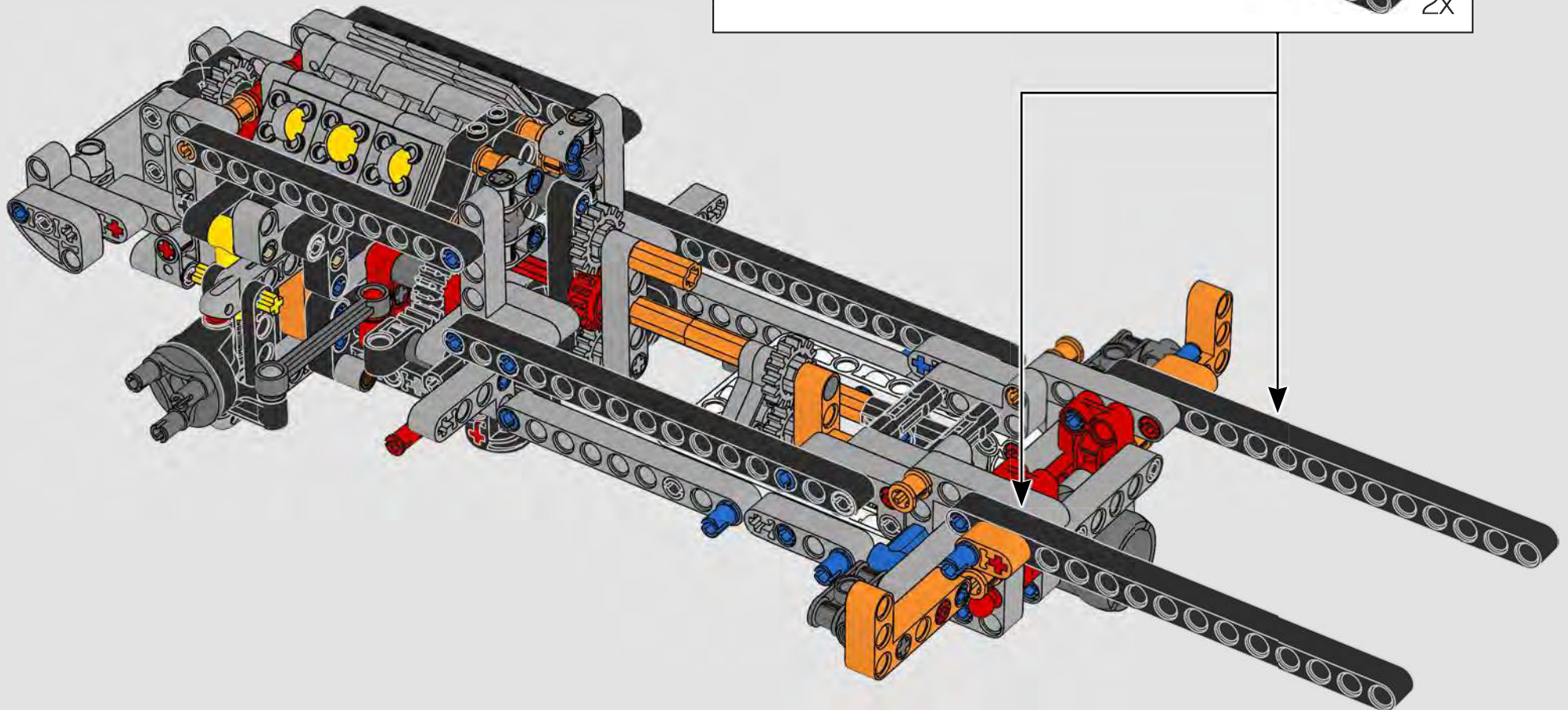
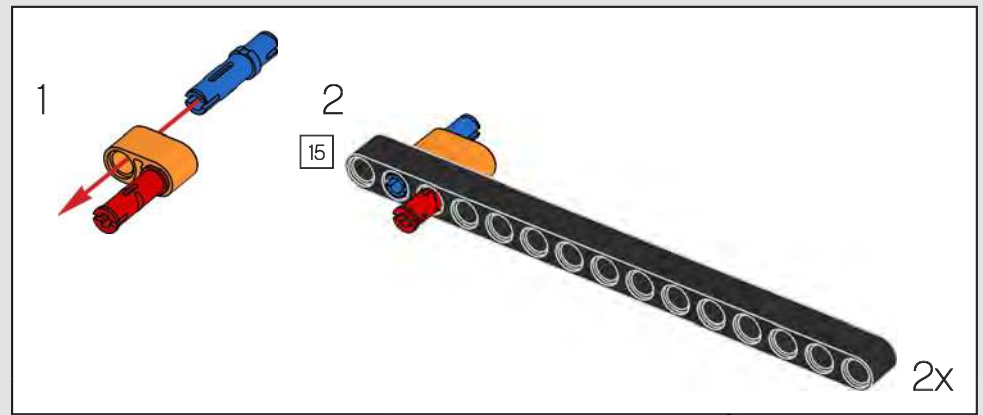



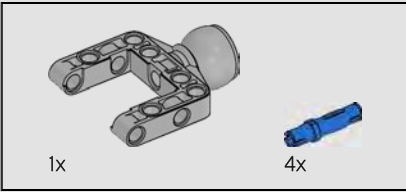
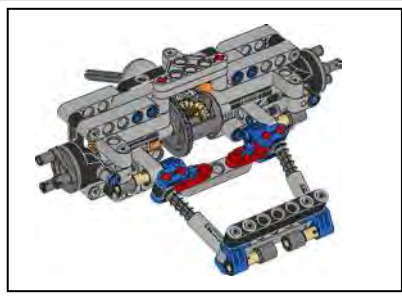

109

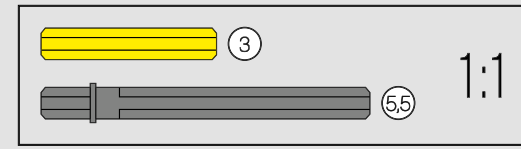
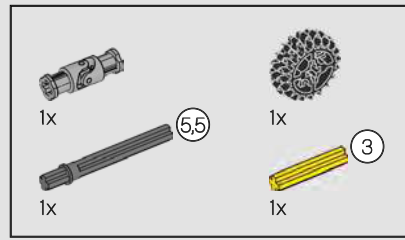
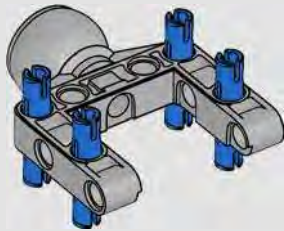

110

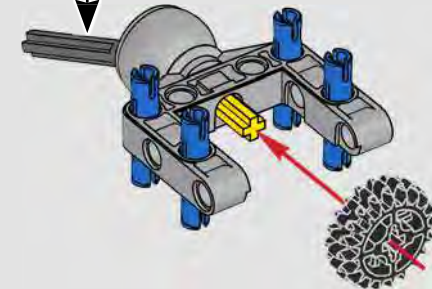
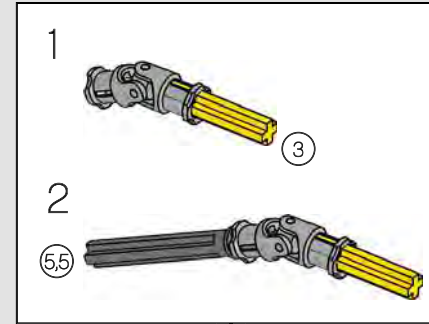

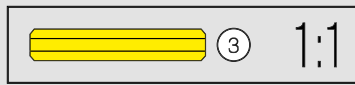
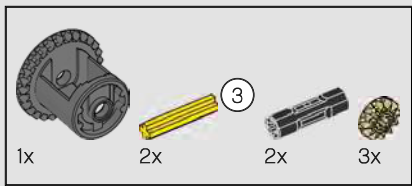

111

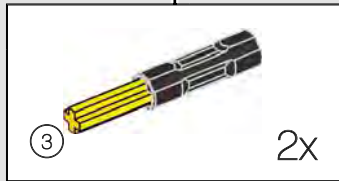
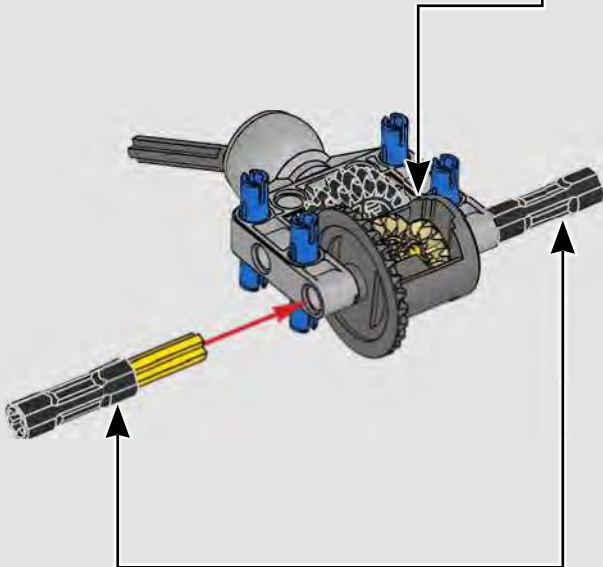
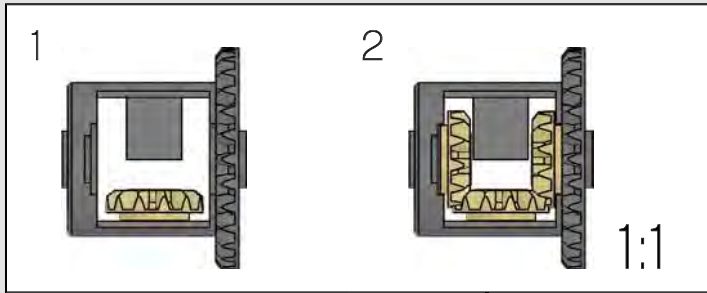

112

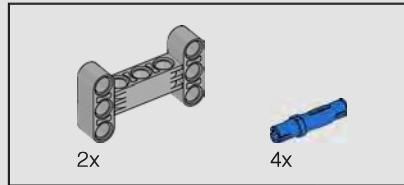
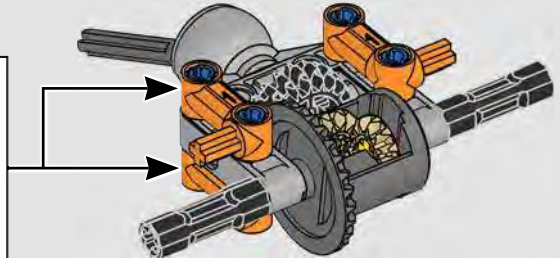
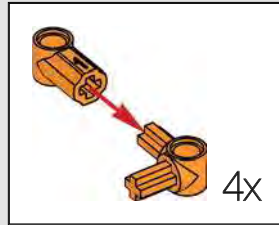

113

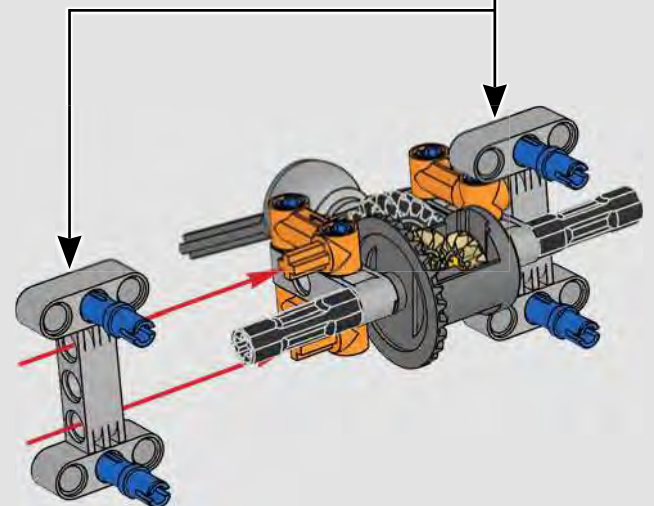
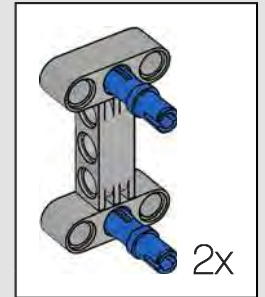

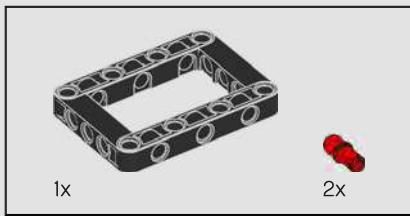

114

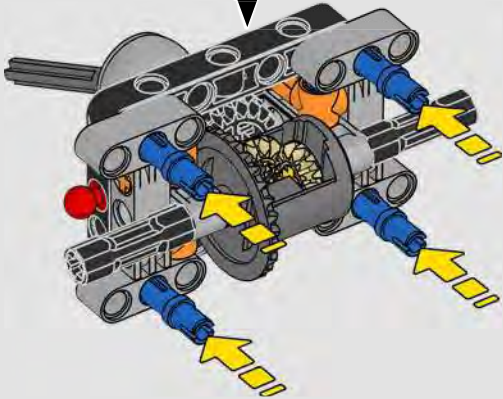
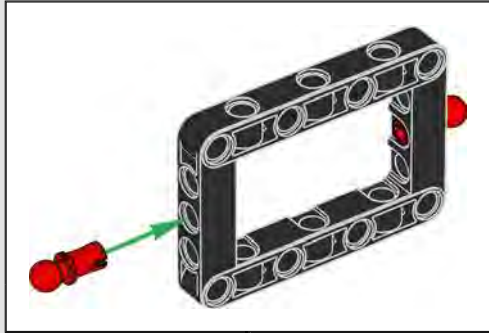

115

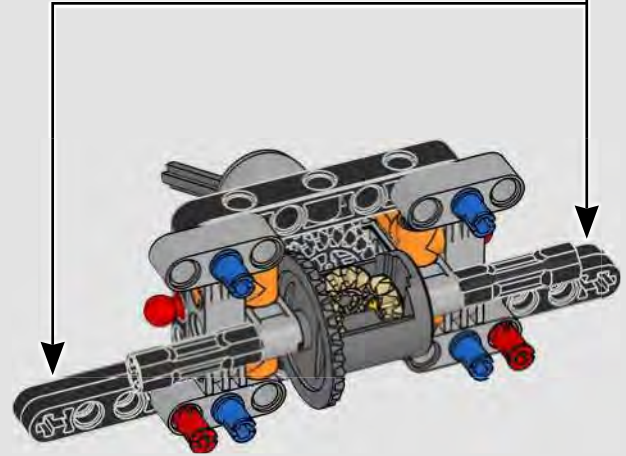
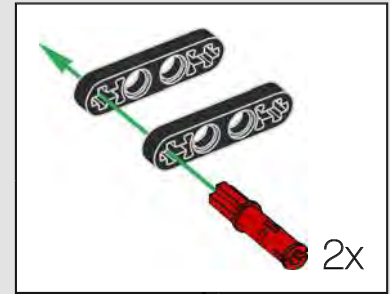



116

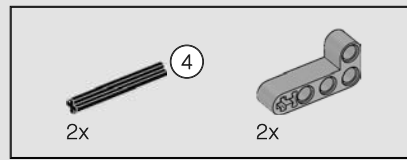
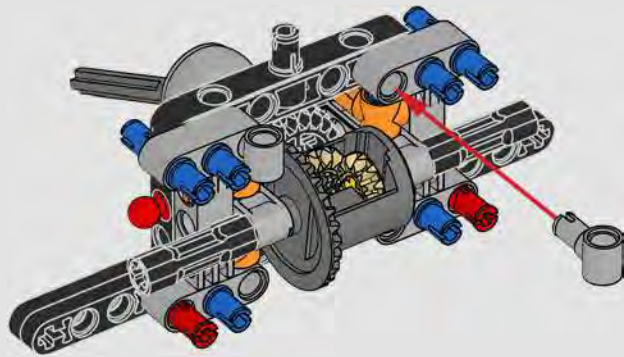

117

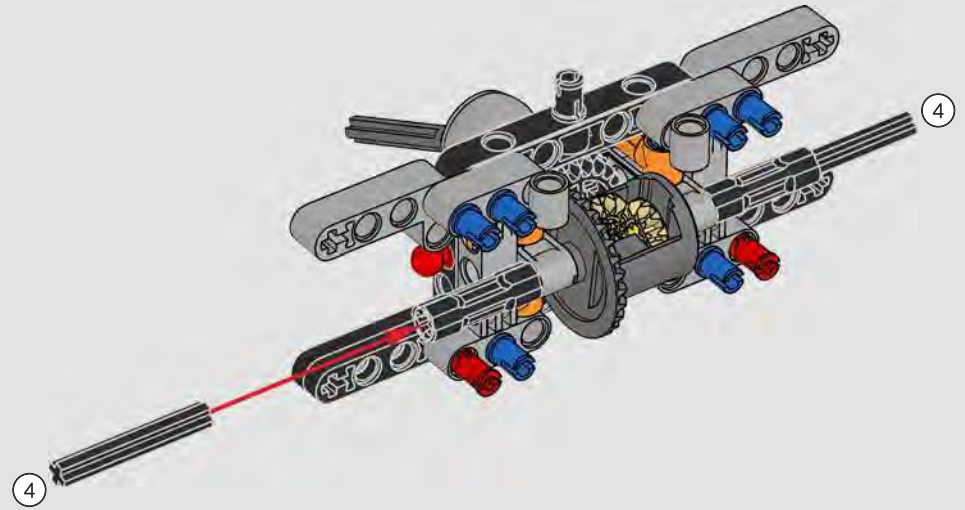
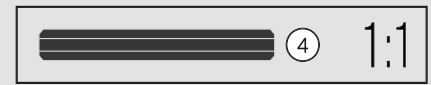

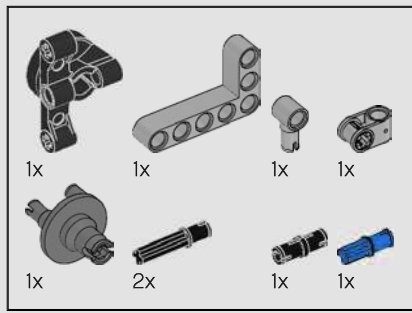

118

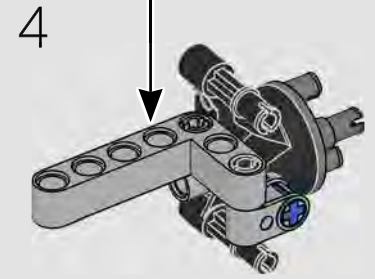
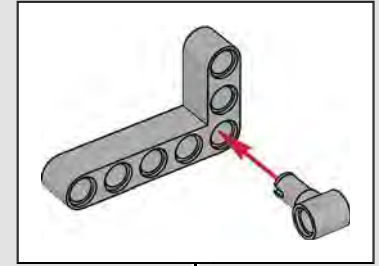
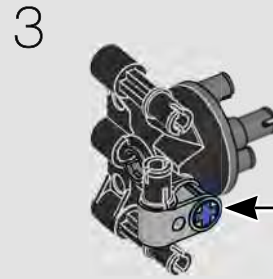
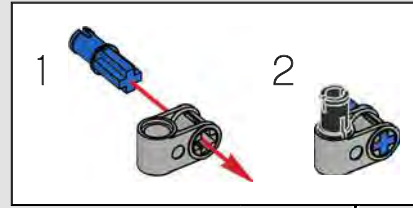
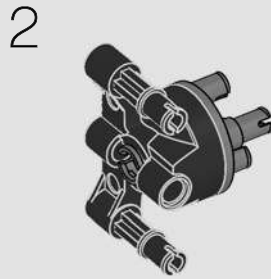
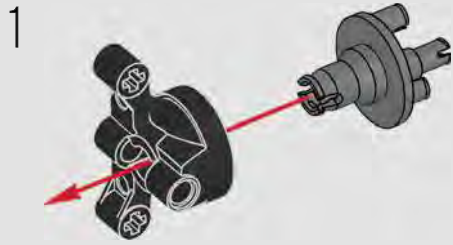

119

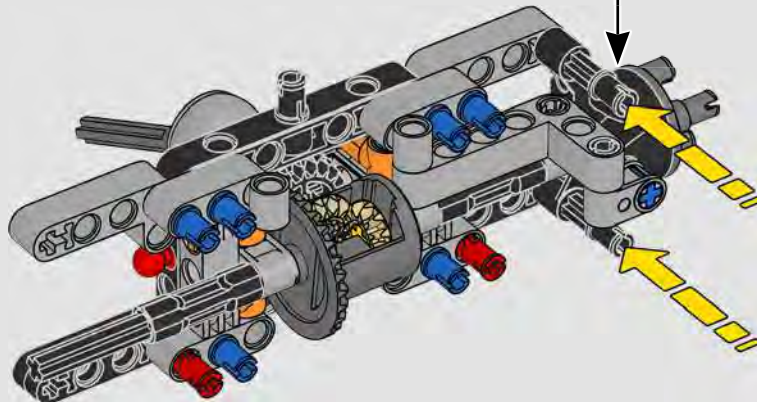

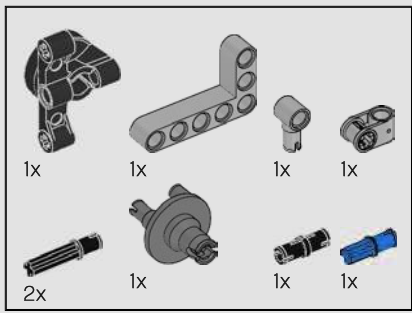

120

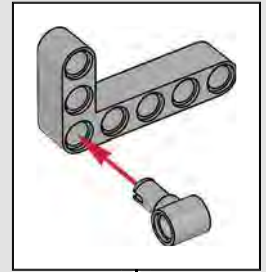
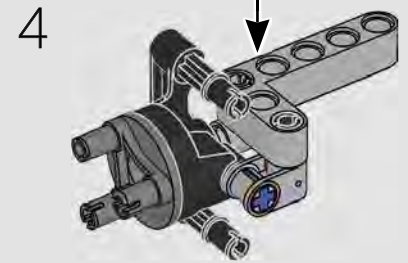
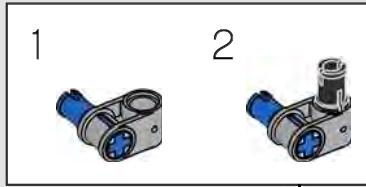
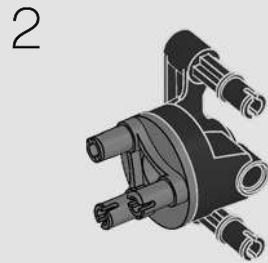
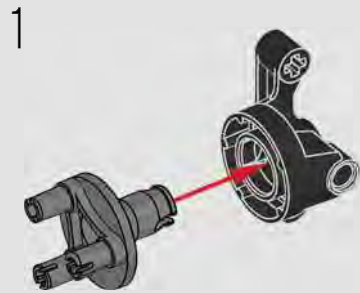

121

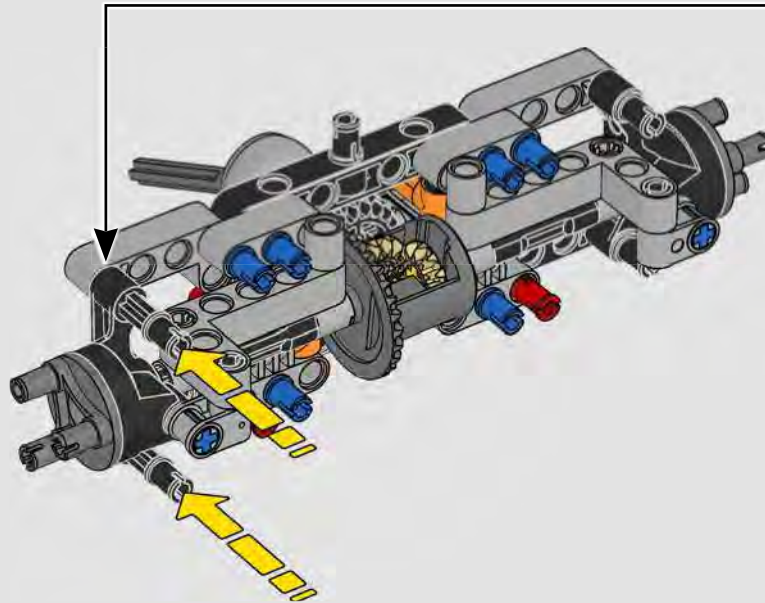

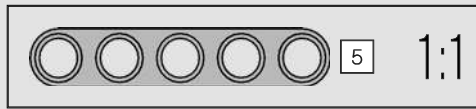
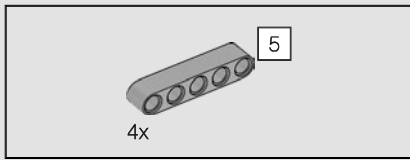

122

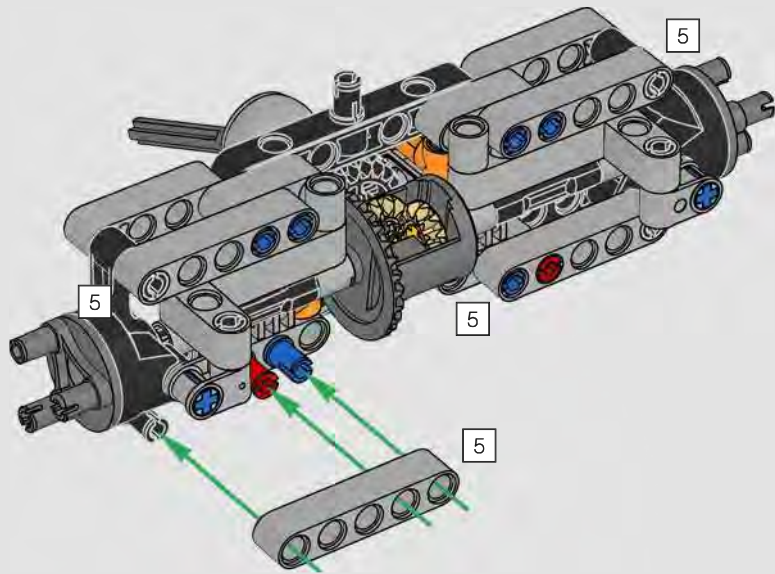

123

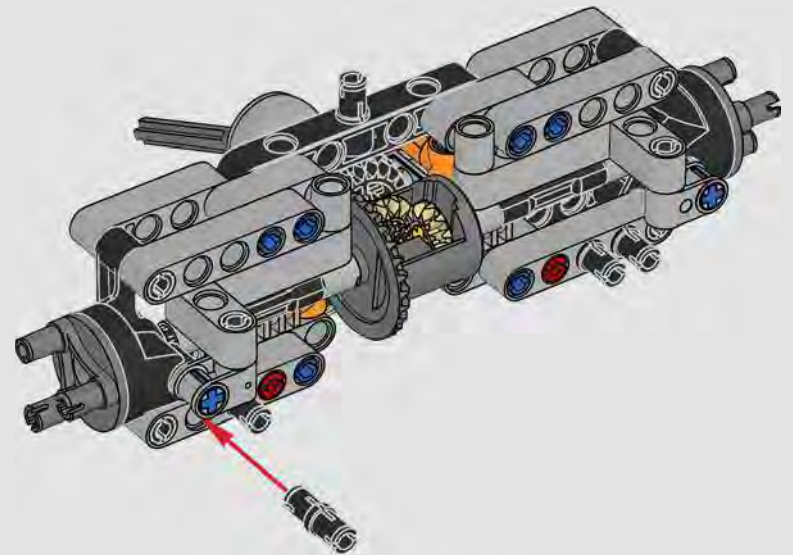

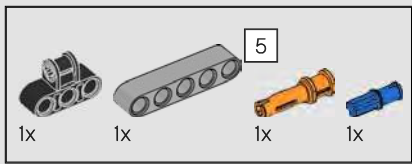

124

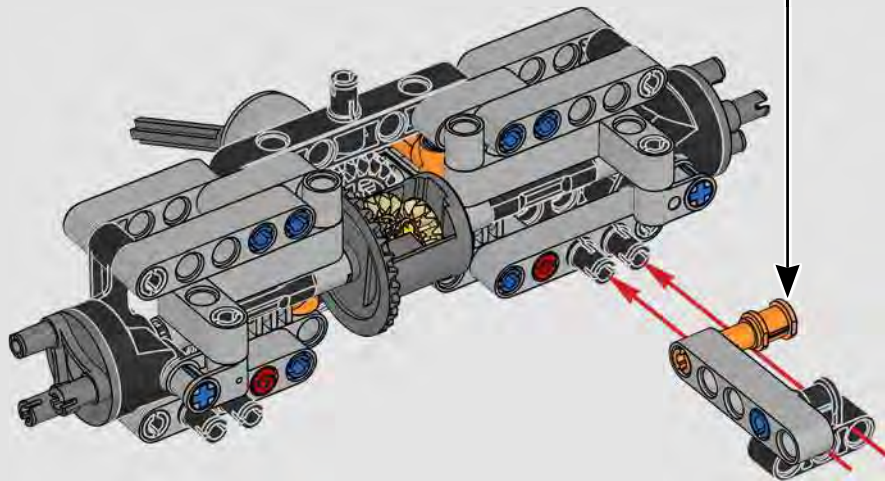
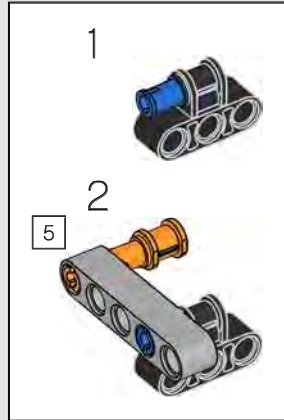
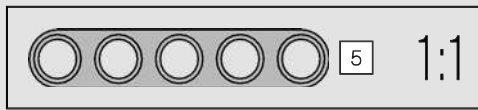

125

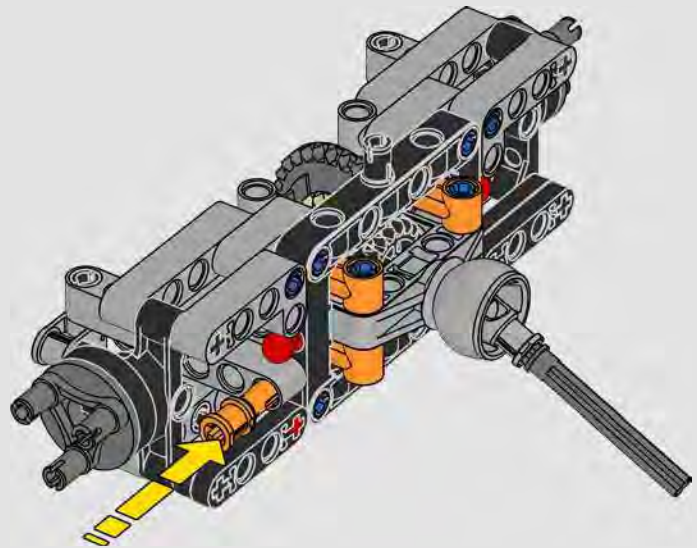
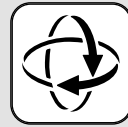



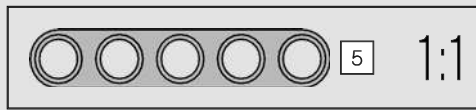
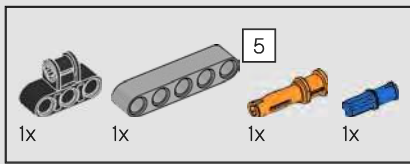

126

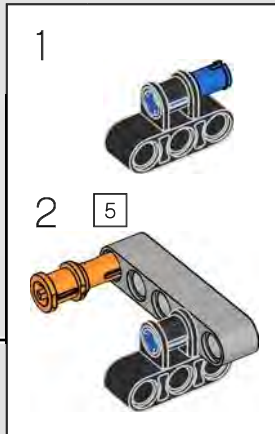
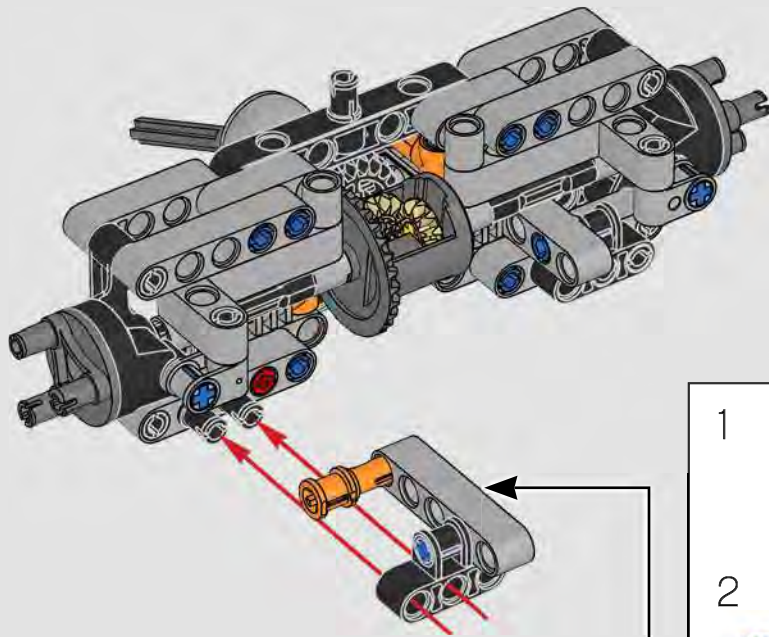

127

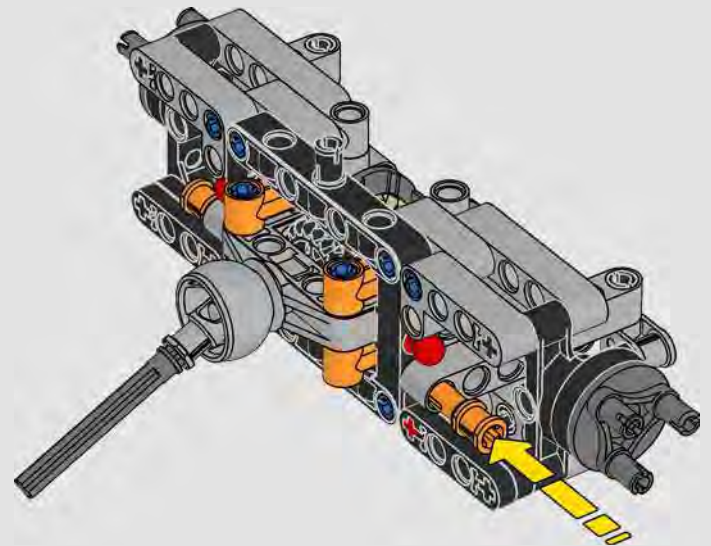
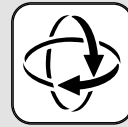



128

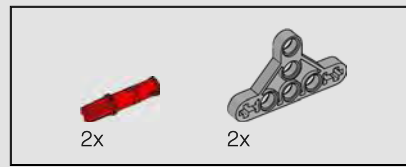
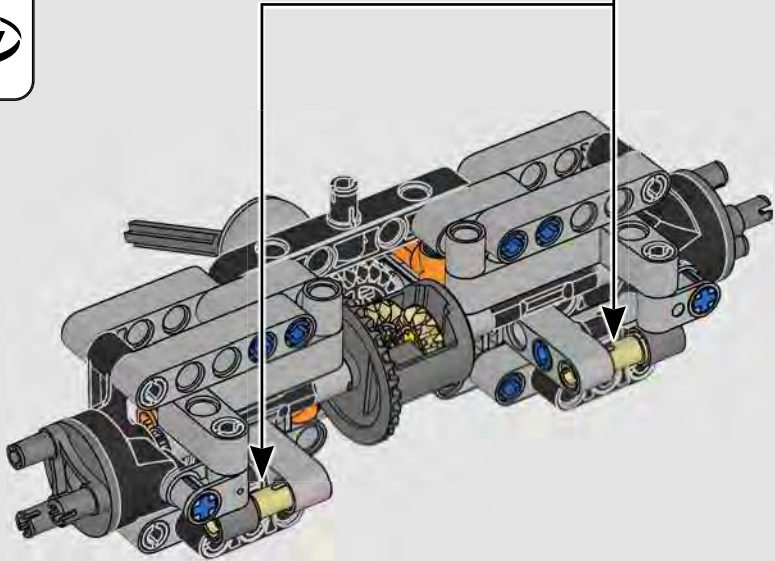

129

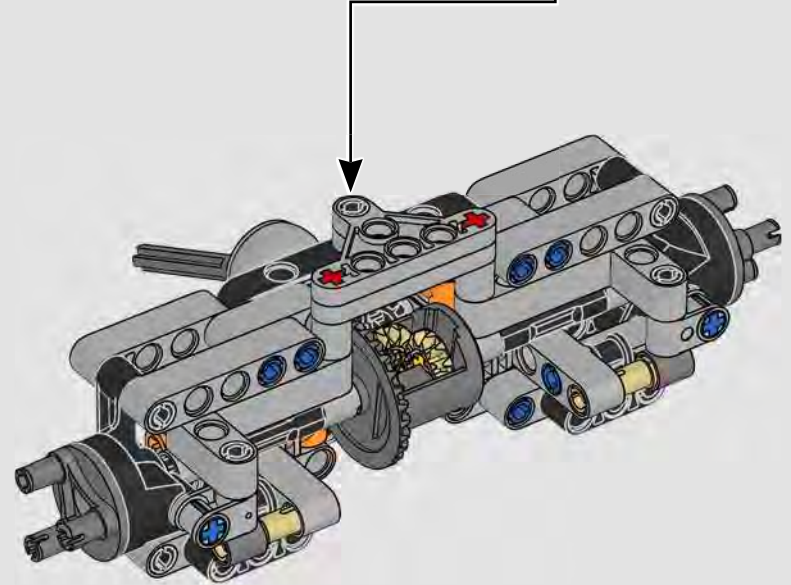
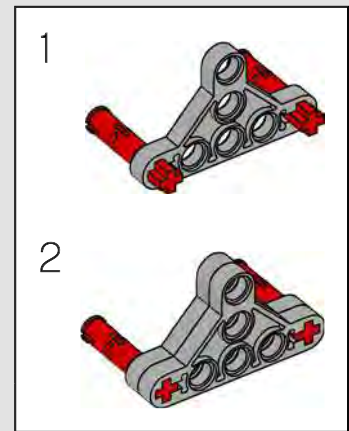

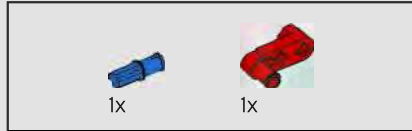
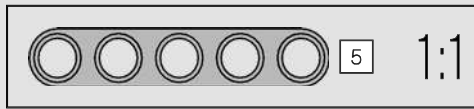
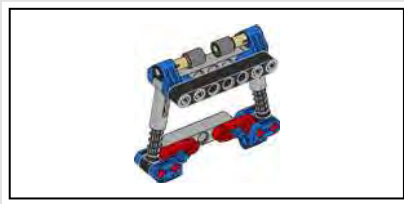

130

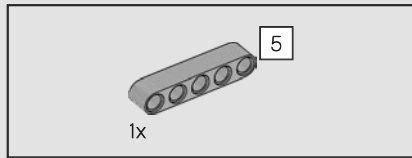
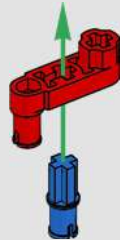

131

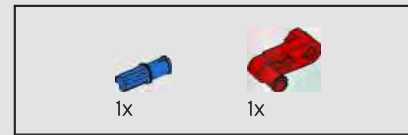
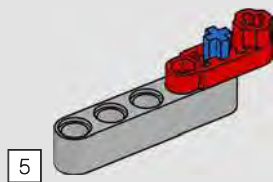

132

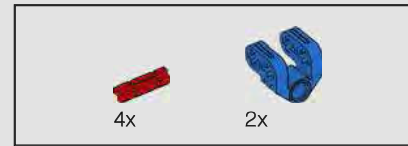
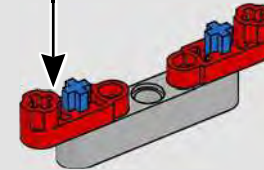
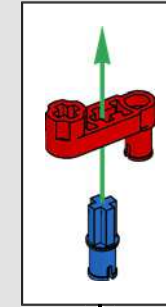

133

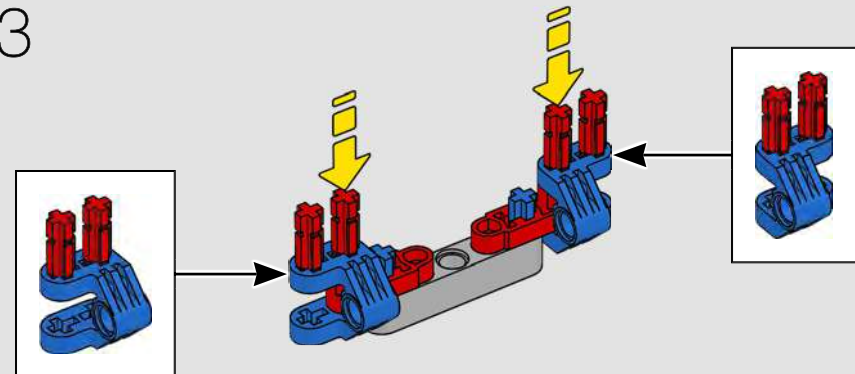

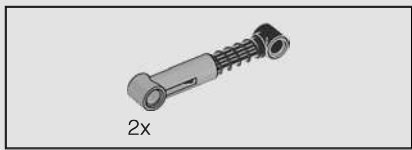

134

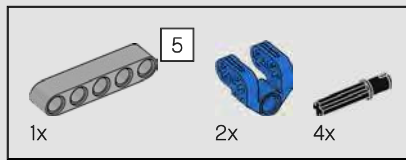
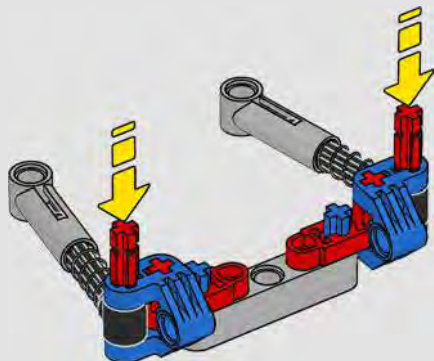

135

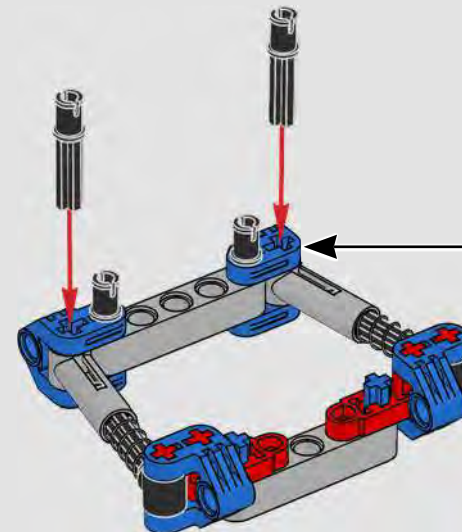
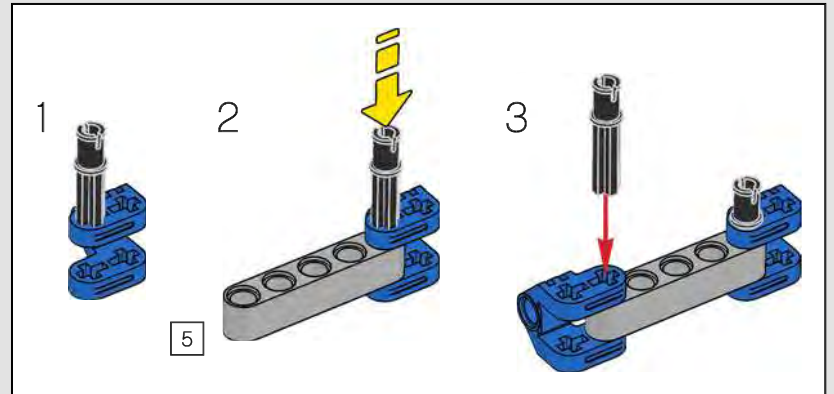
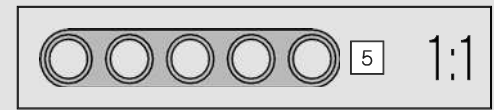

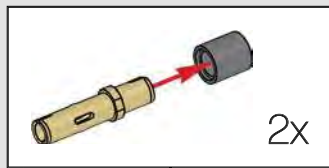

136

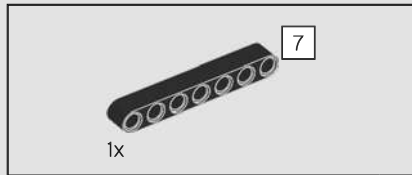
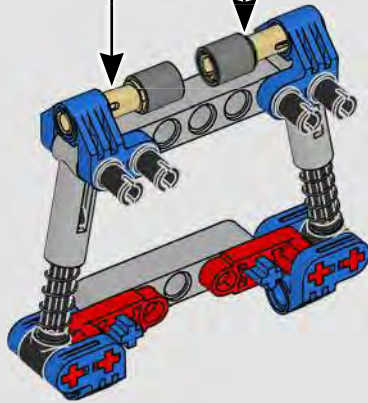

137

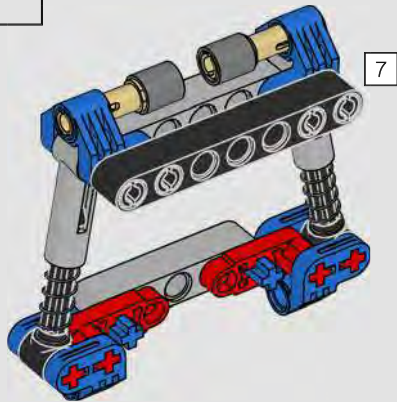

138

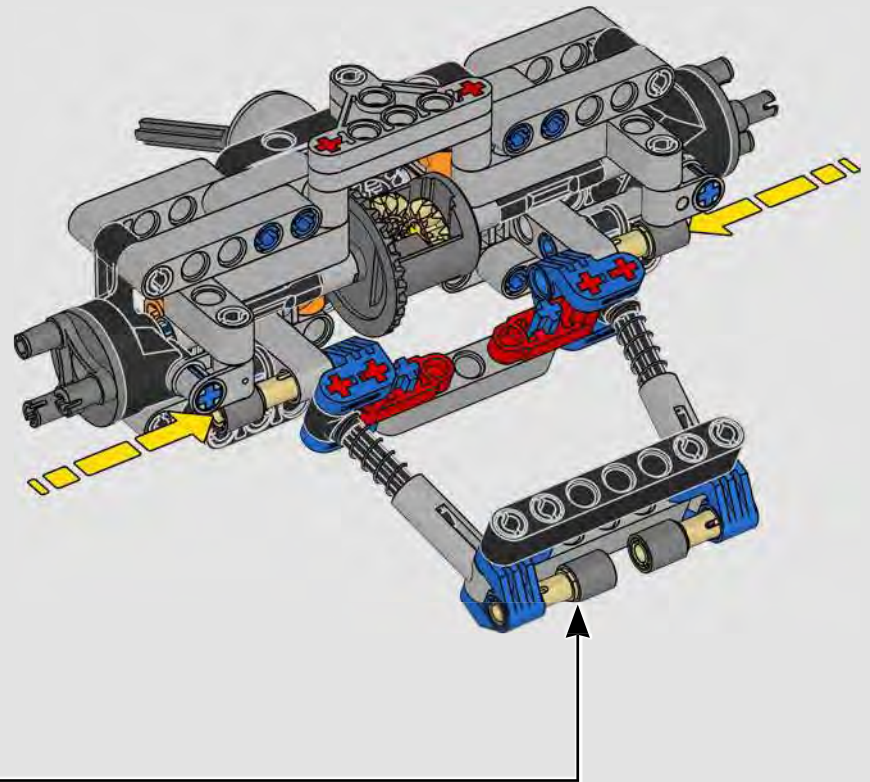

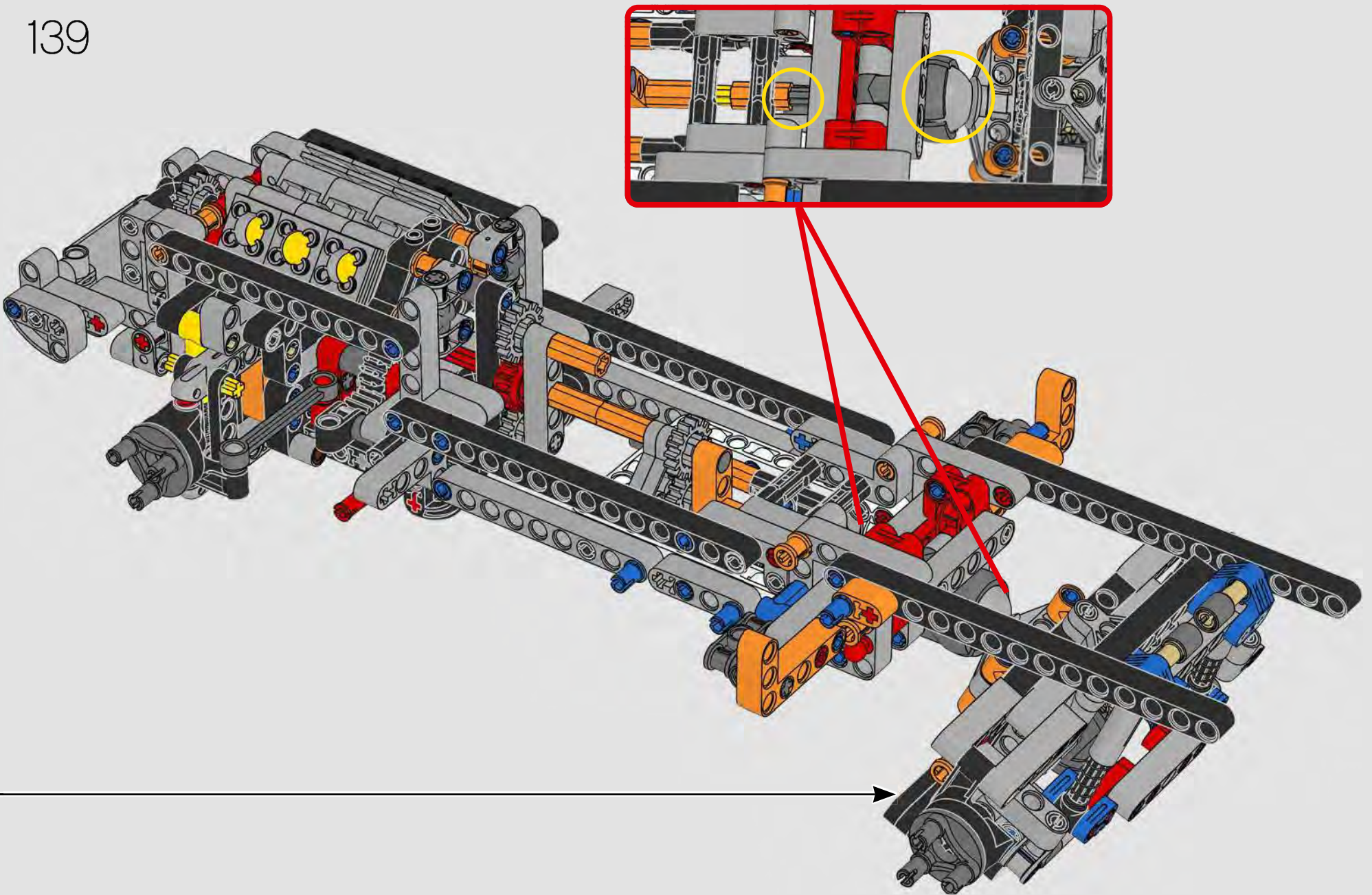

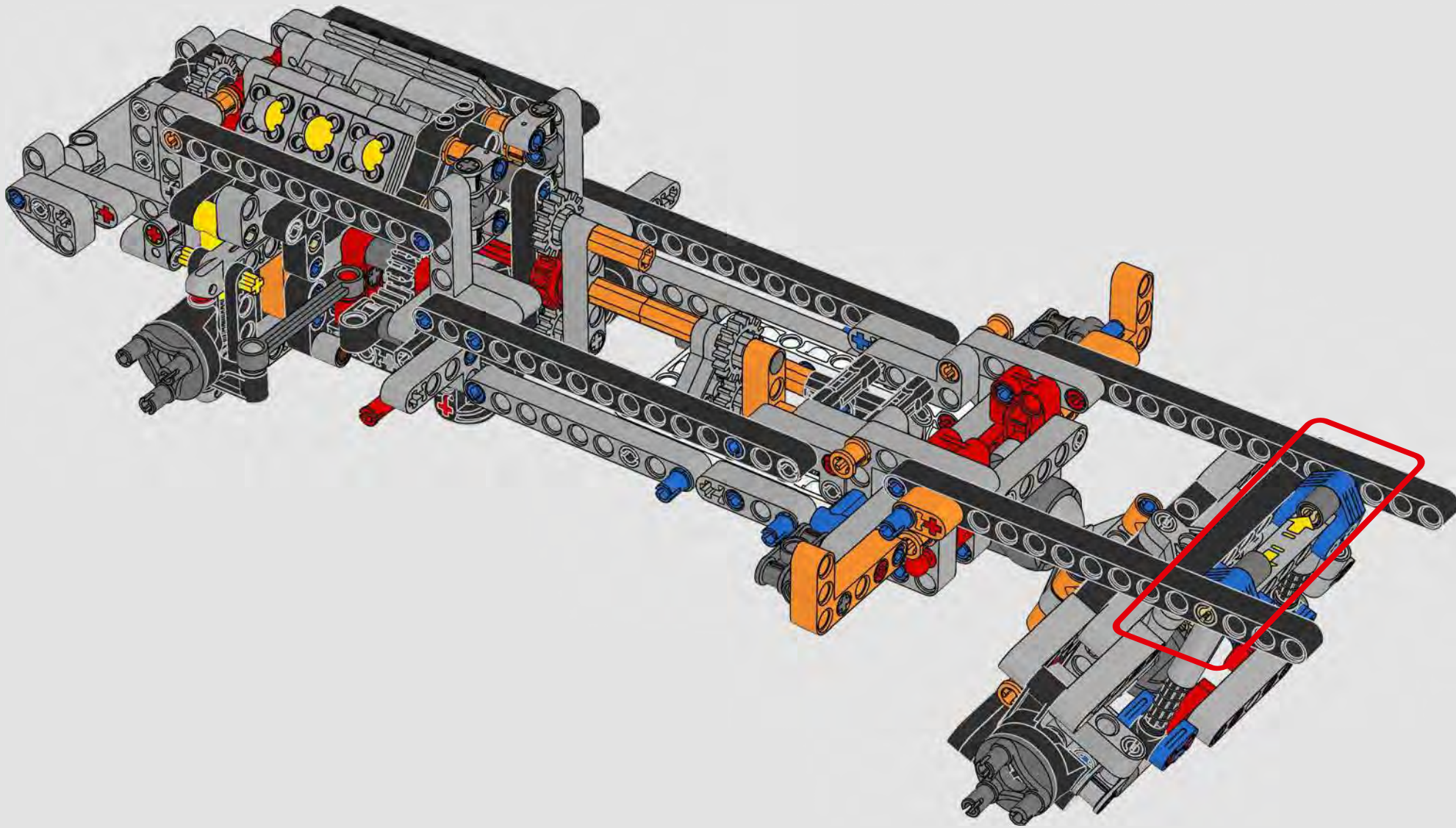

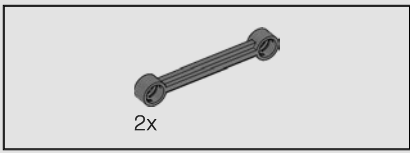

141

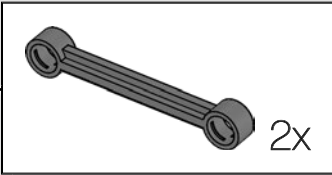
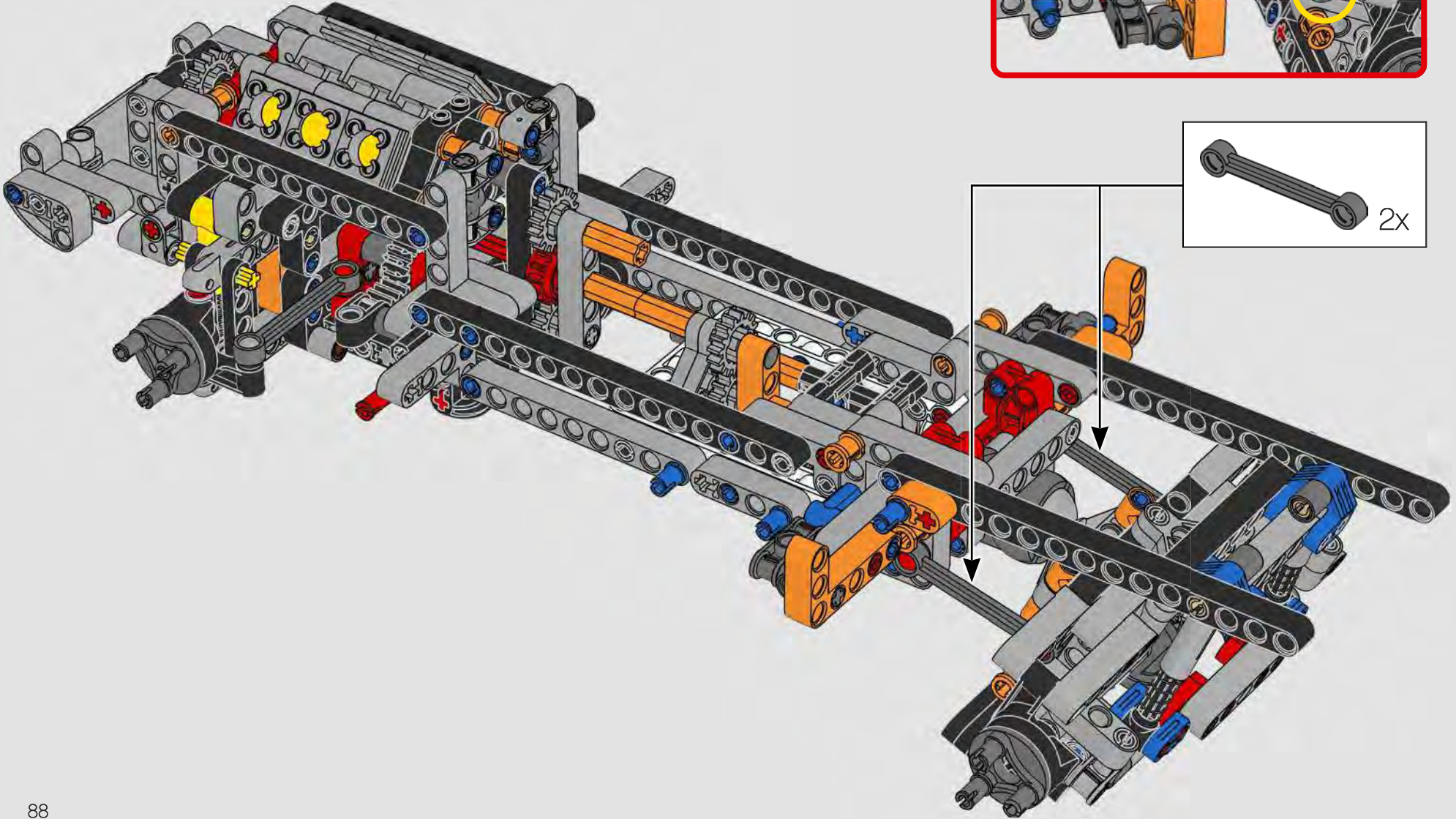
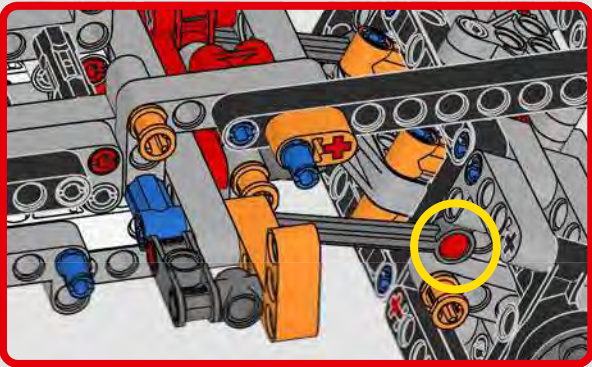



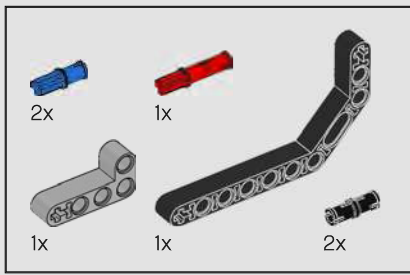

142

1

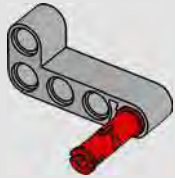

2

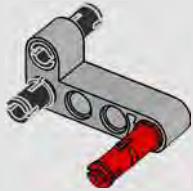

3

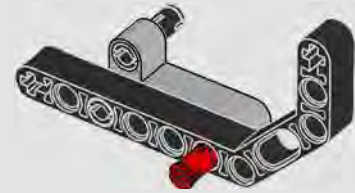

4

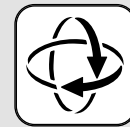
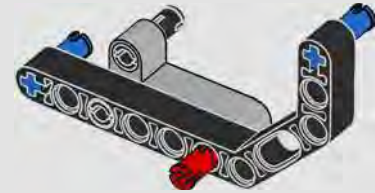

5



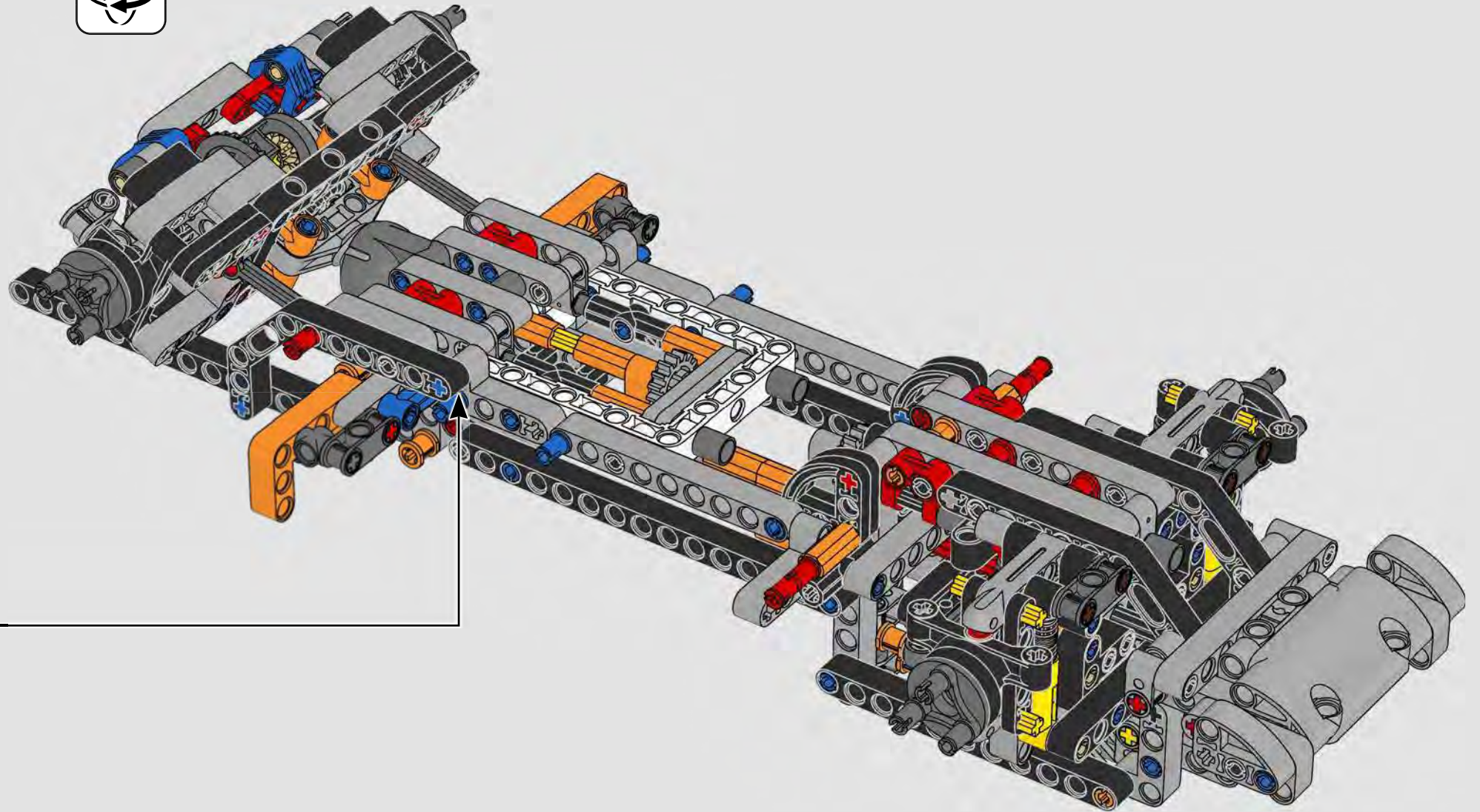

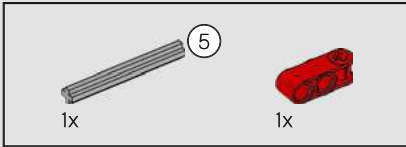

143

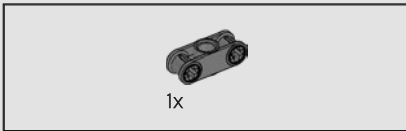
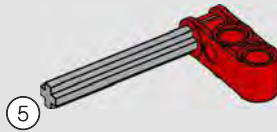

144

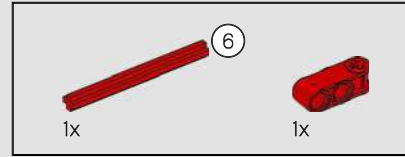
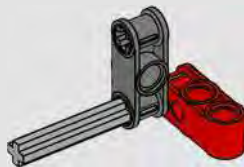

145

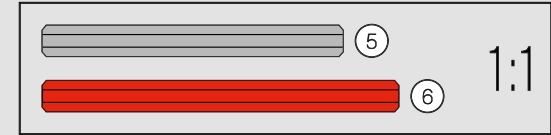
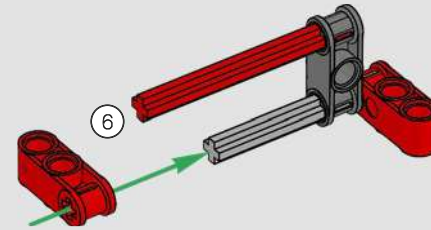

146

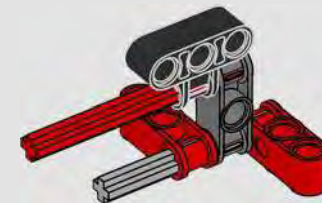

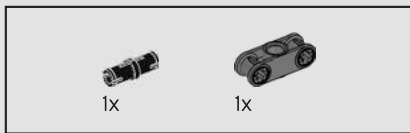

147

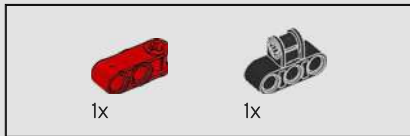
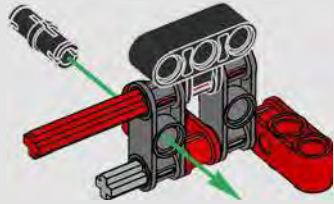

148

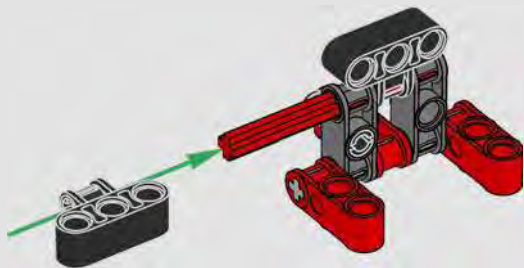

149

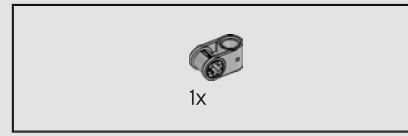
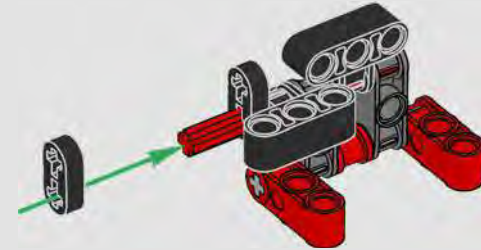

150

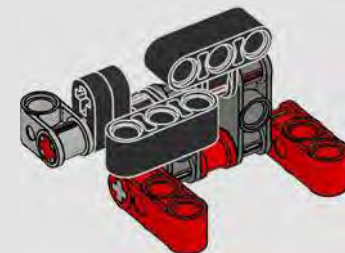

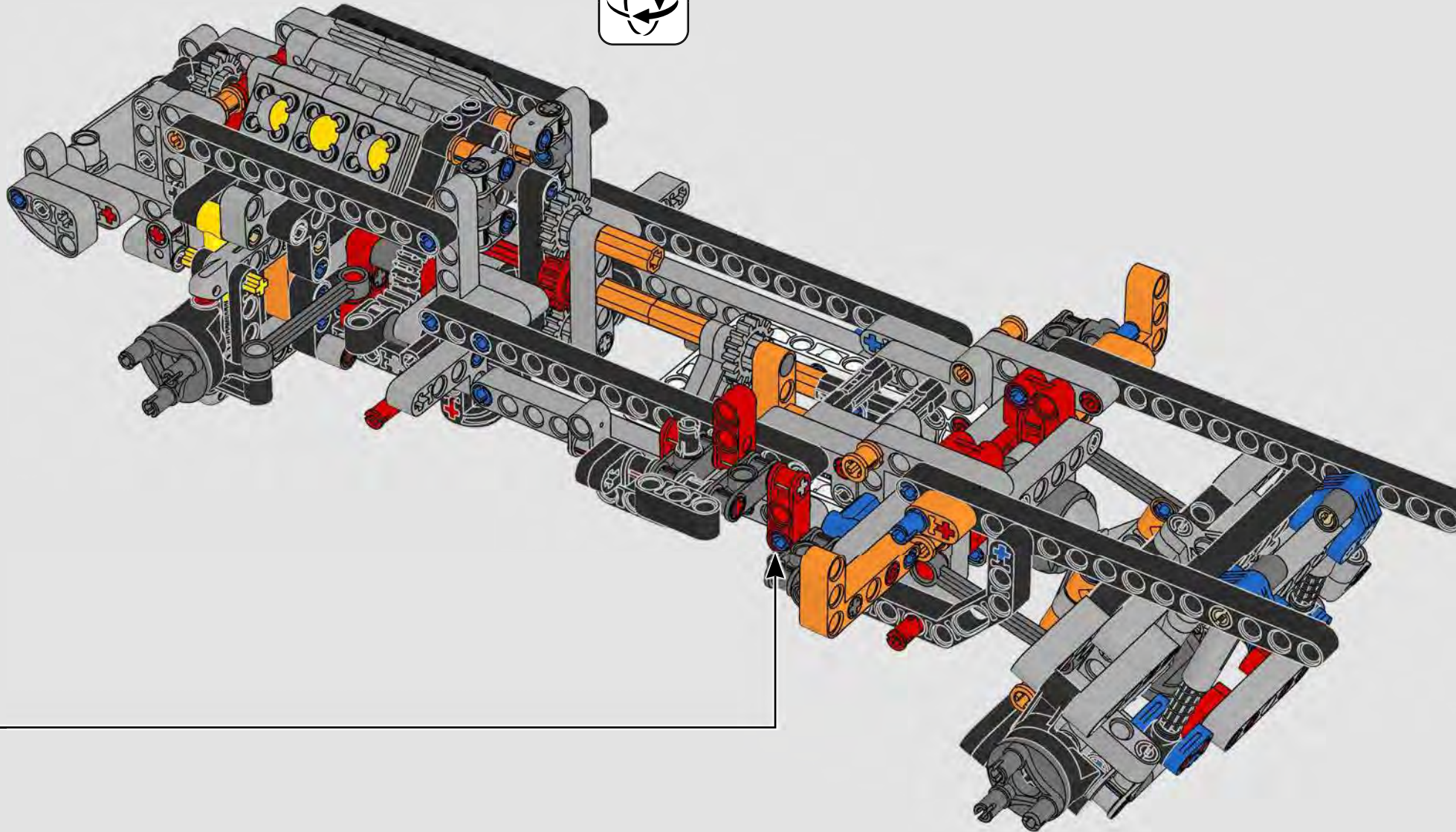

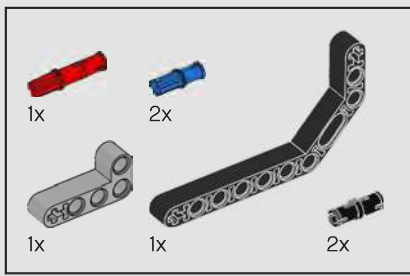

152

1

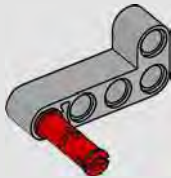

2

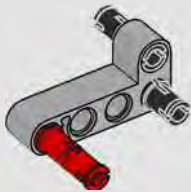

3

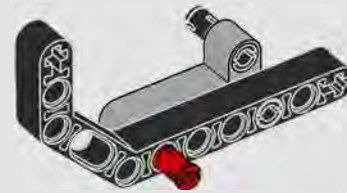

4

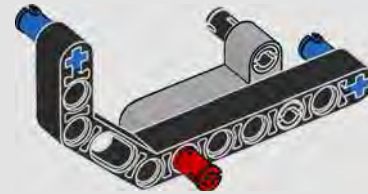

5

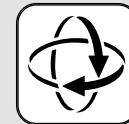

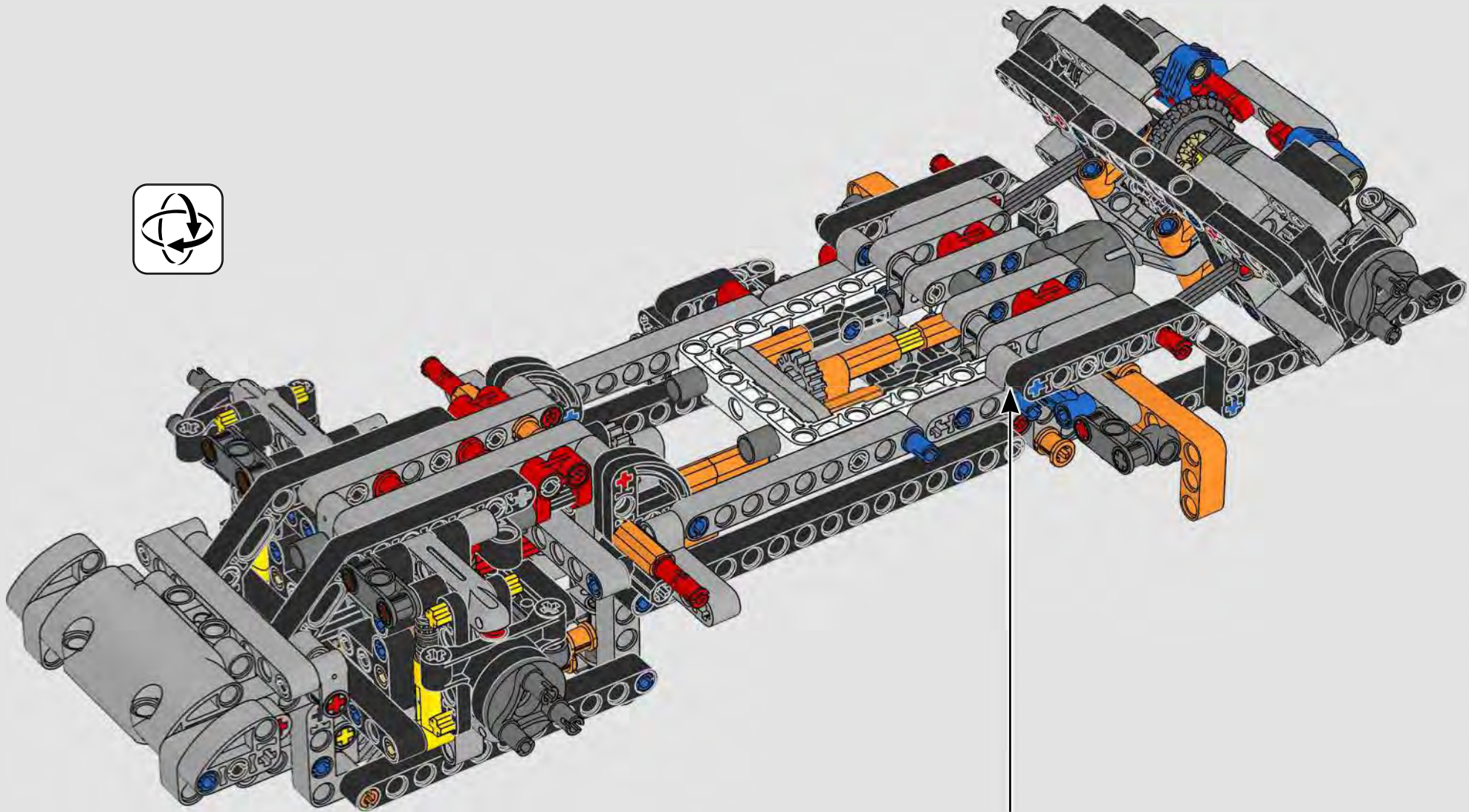

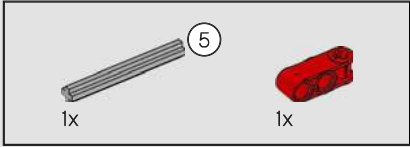

153

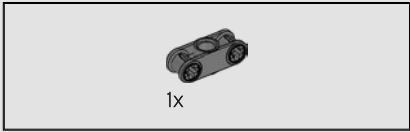
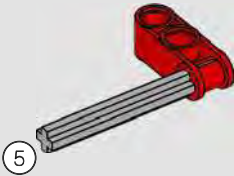

154

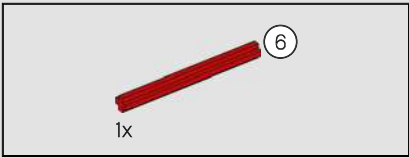
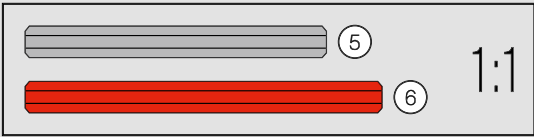
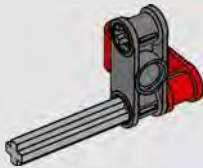

155

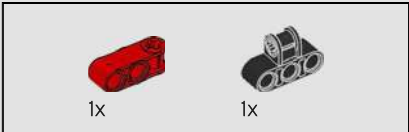
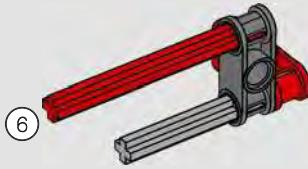

156

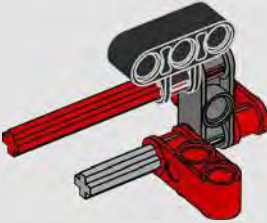



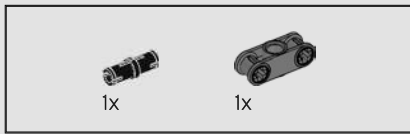

157

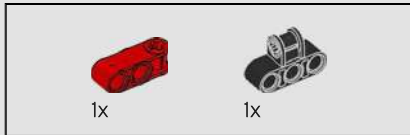
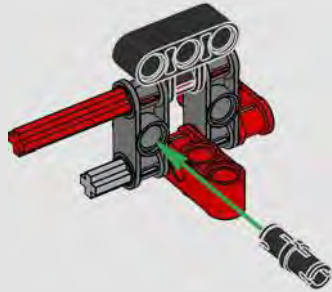

158

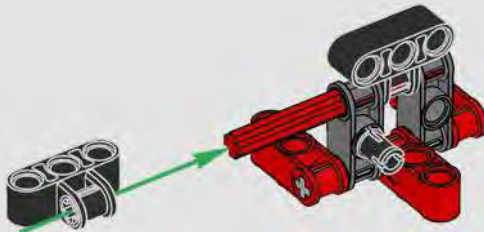

159

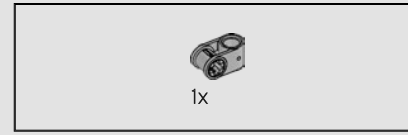
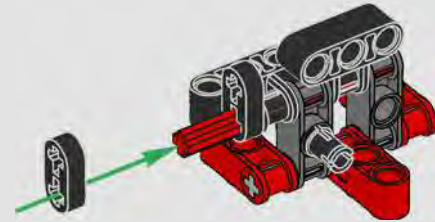

160

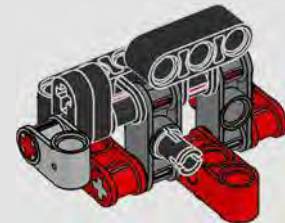

161

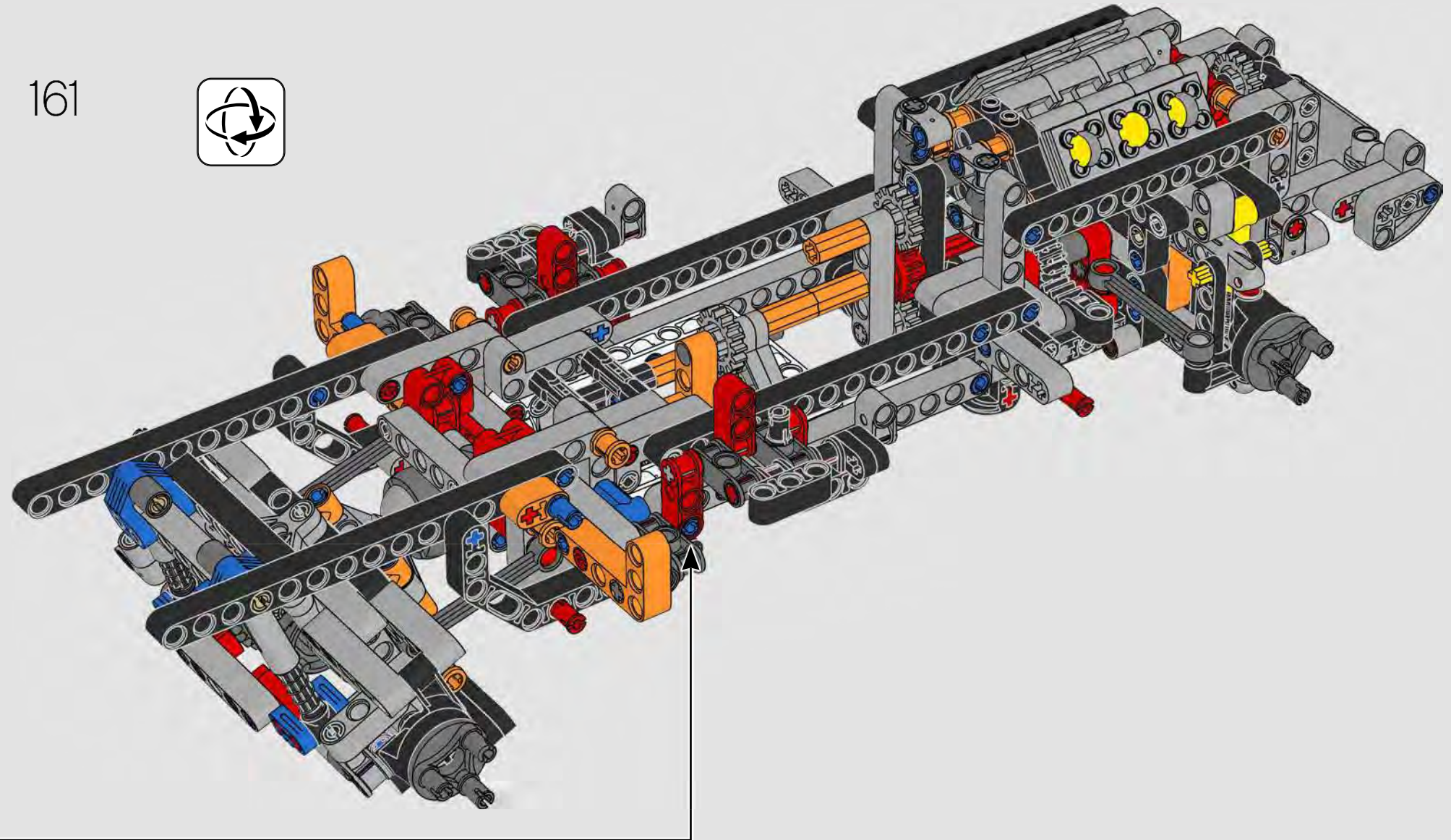

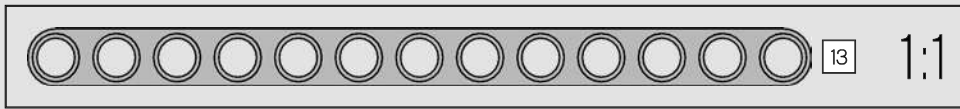
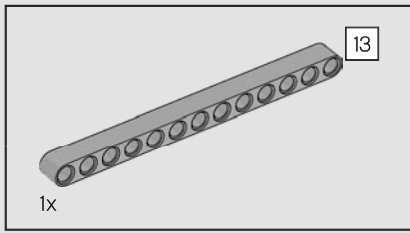

162

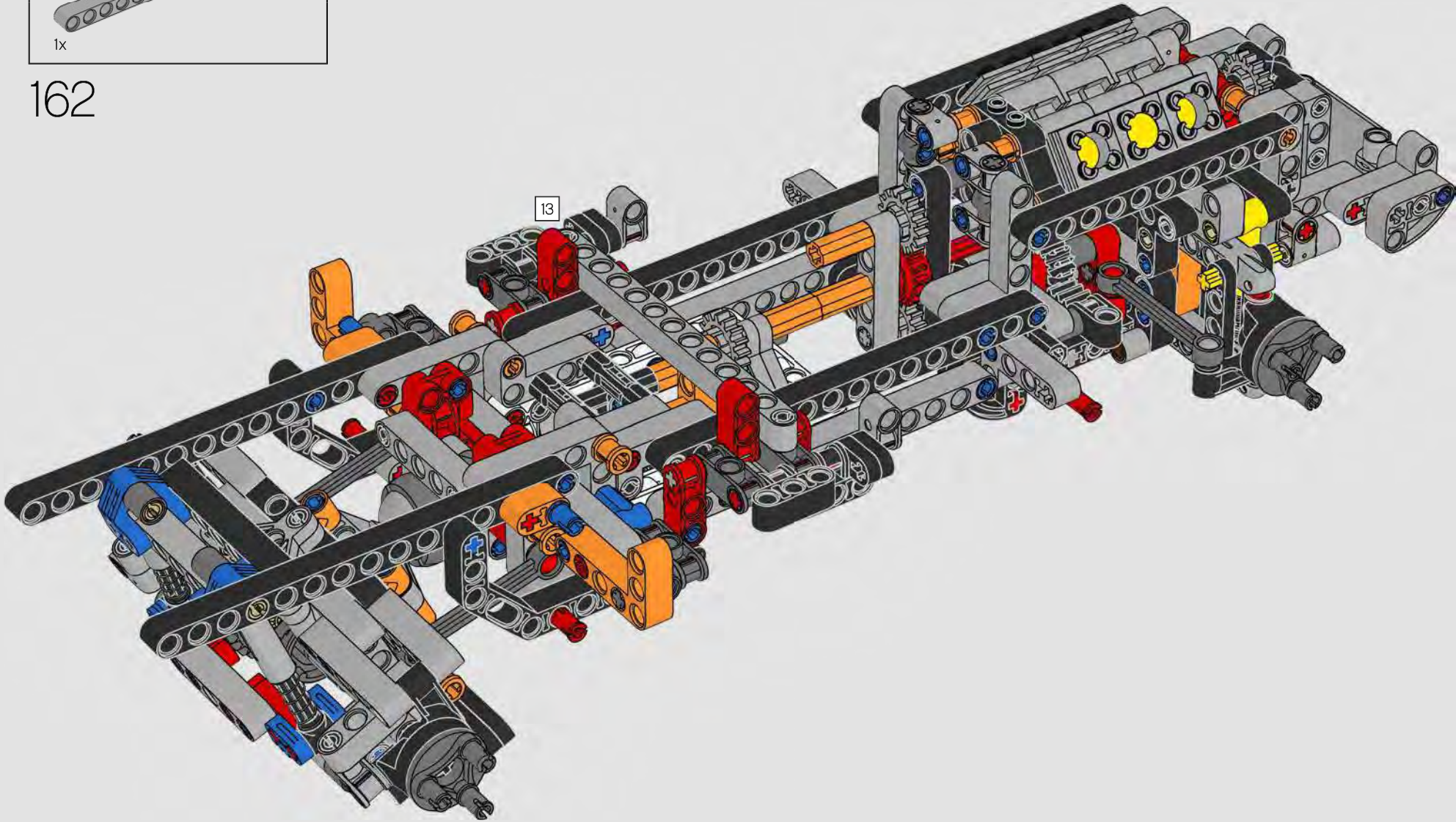

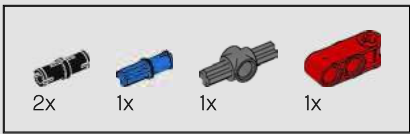

163

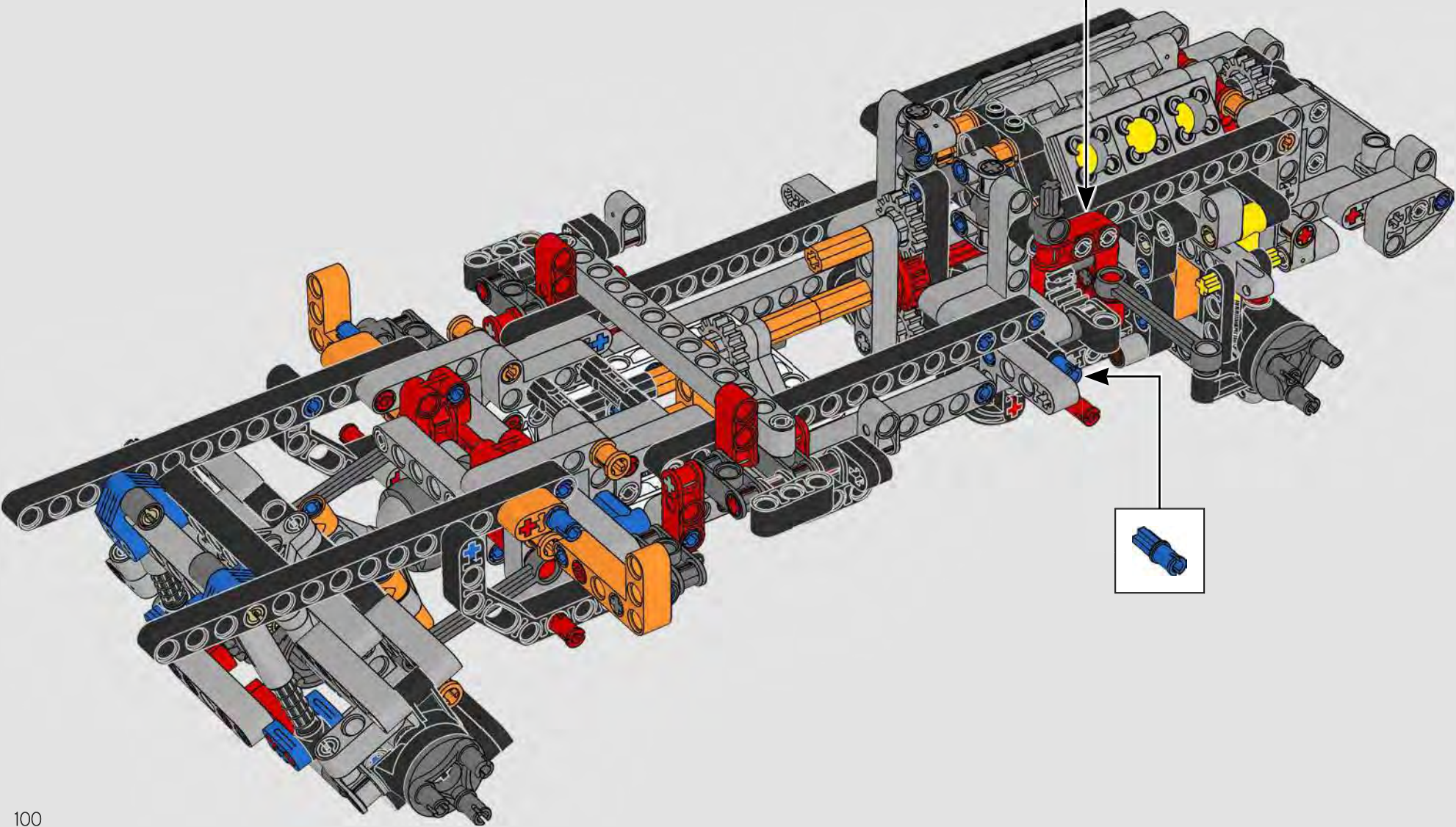
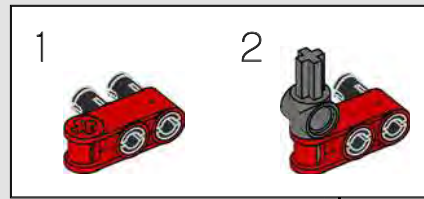

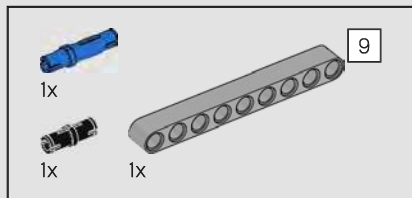

164

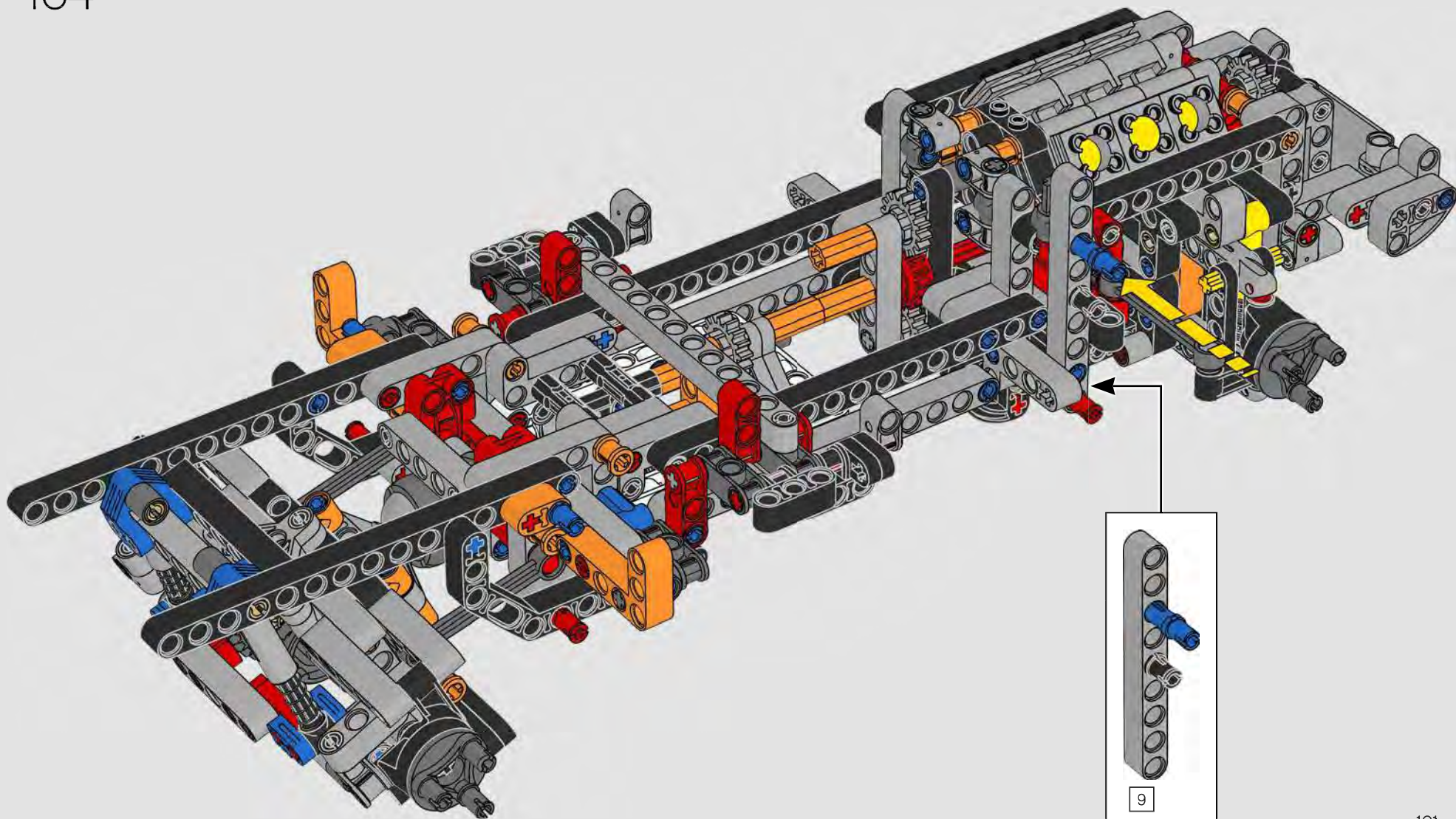

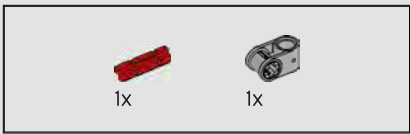

165

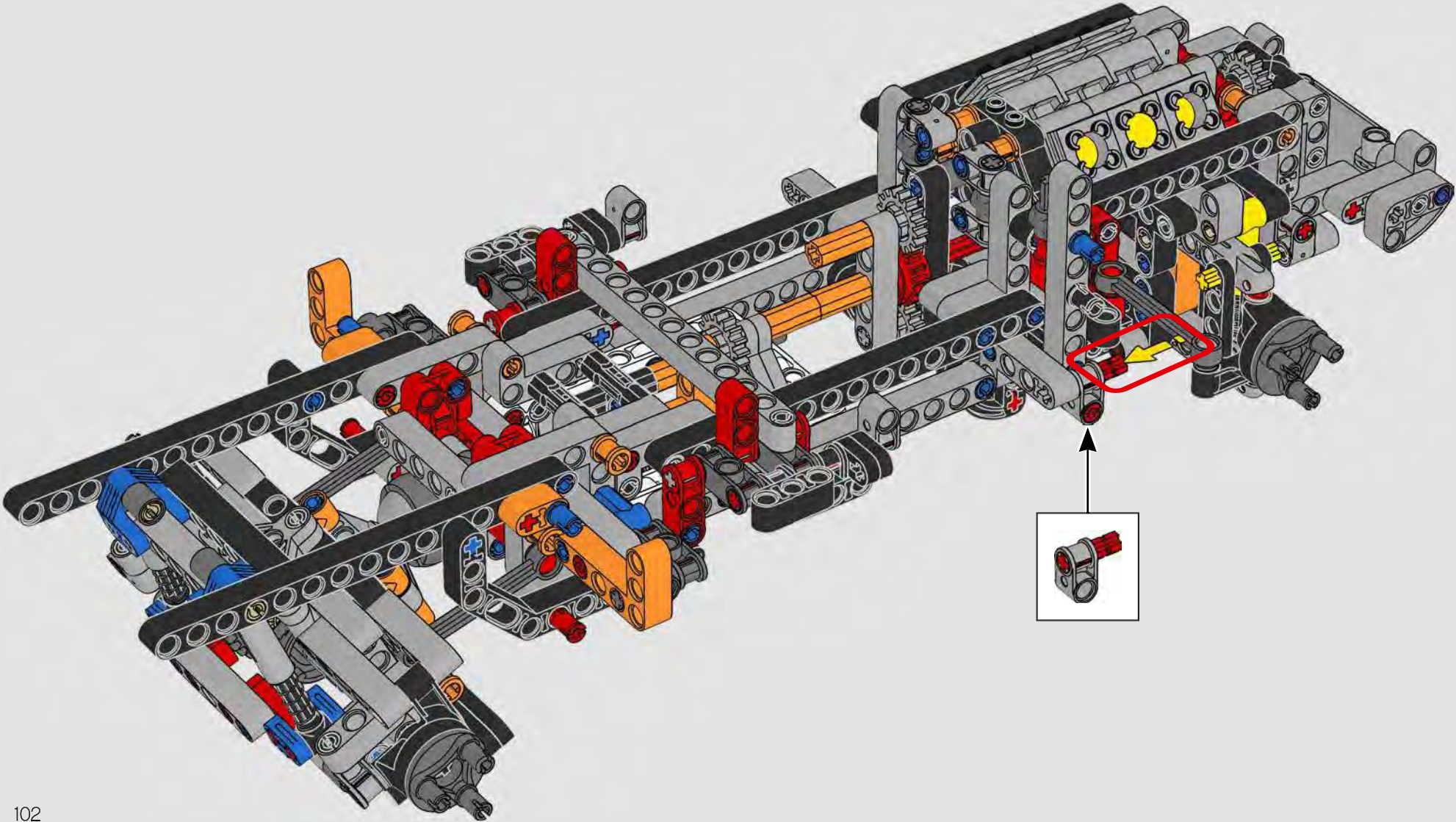

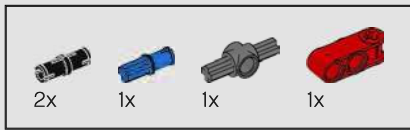

166

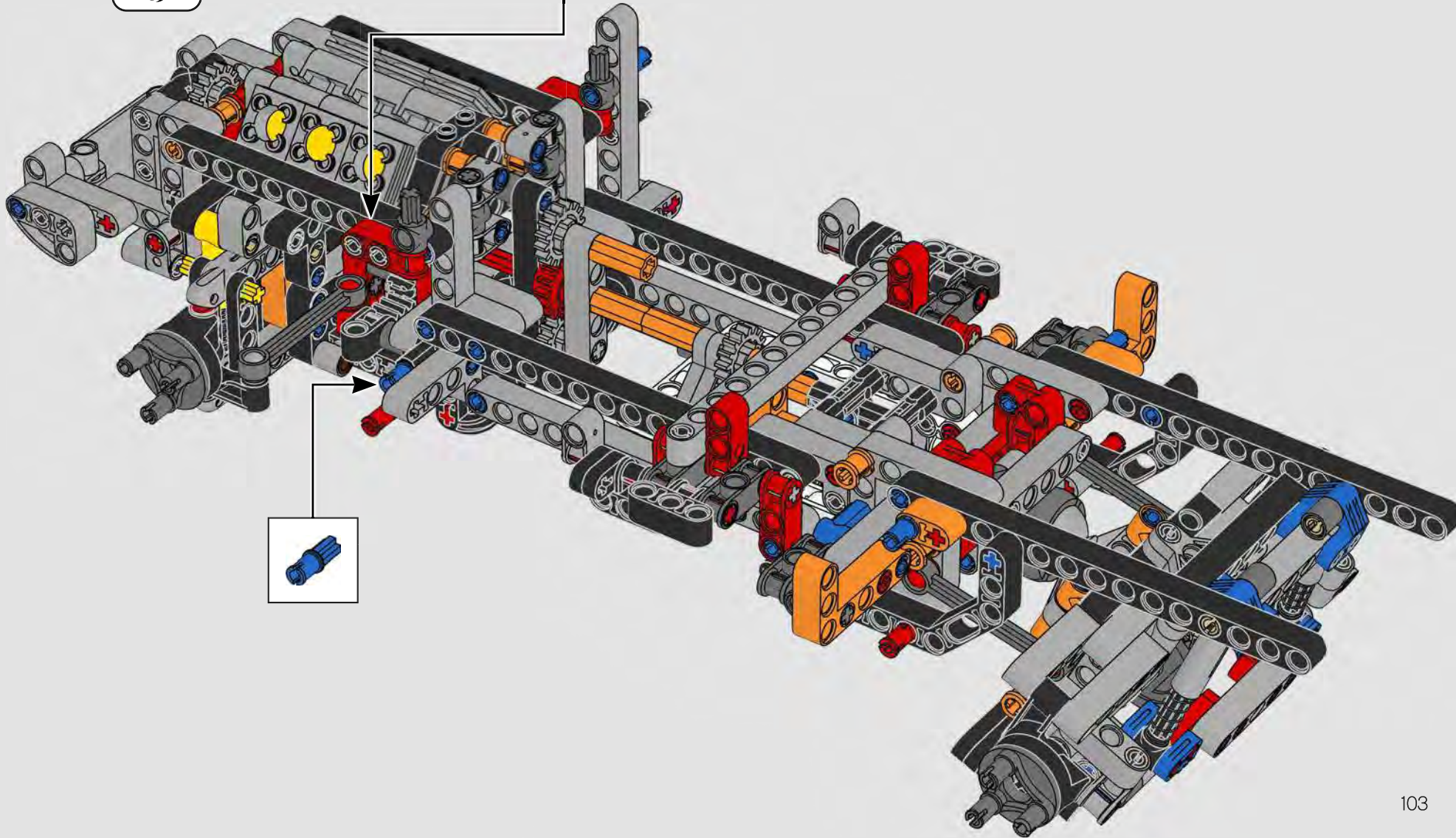

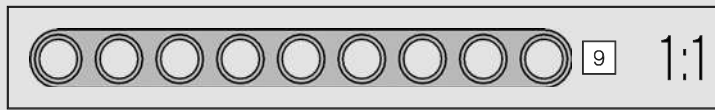
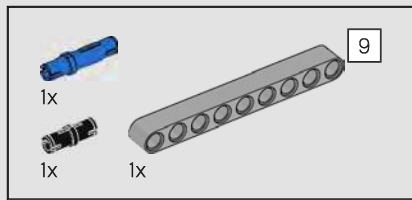

167

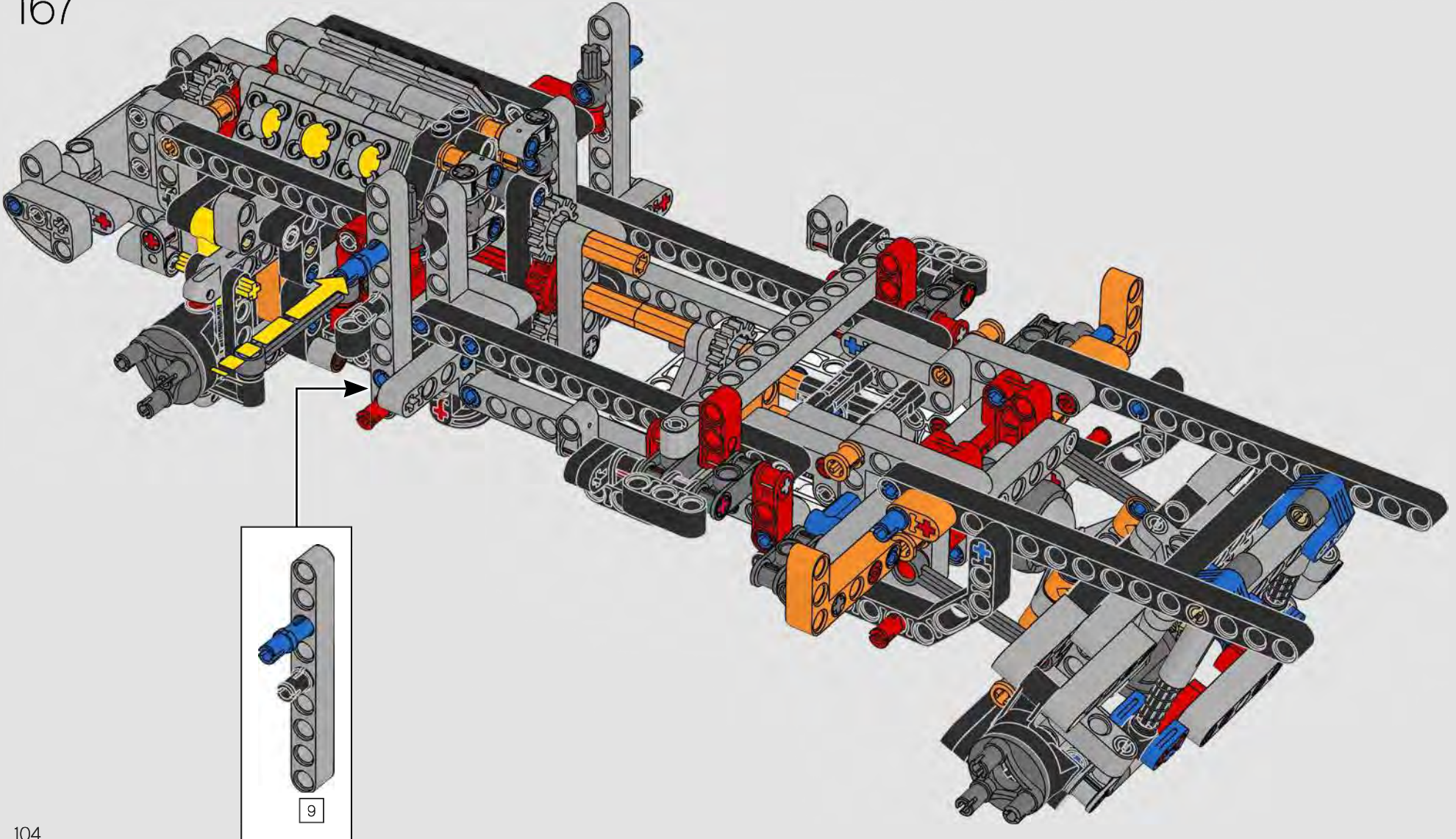



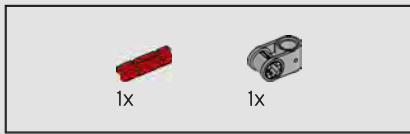

168

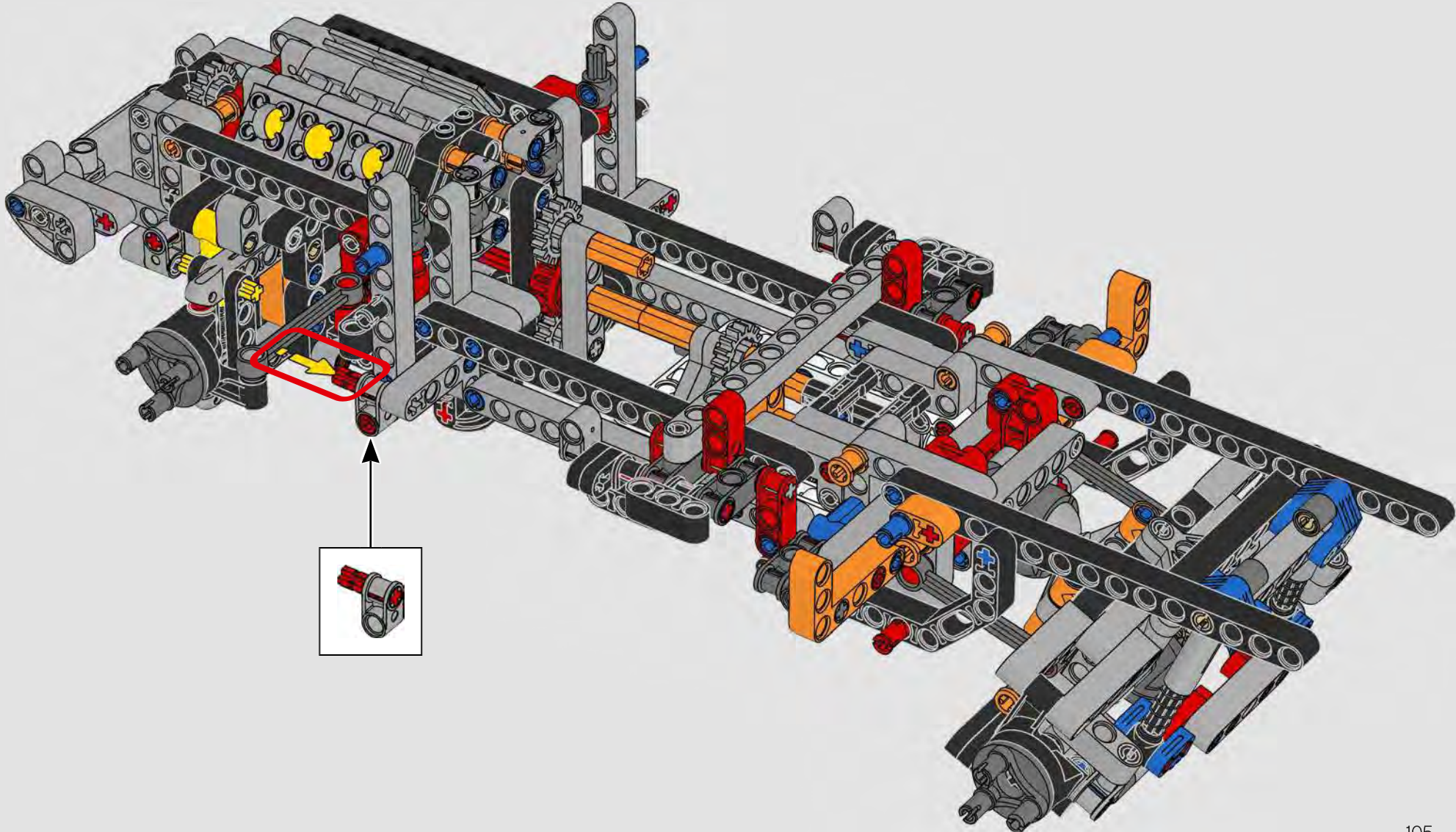

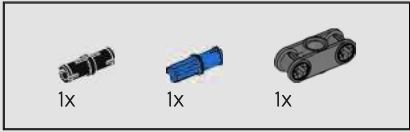

169

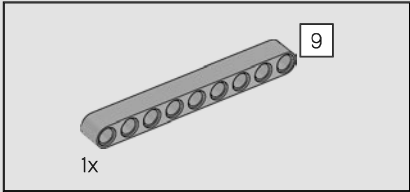

170

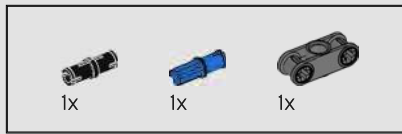
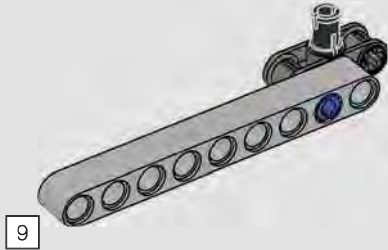

171

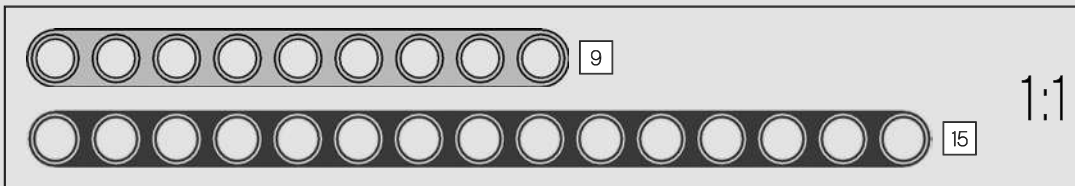
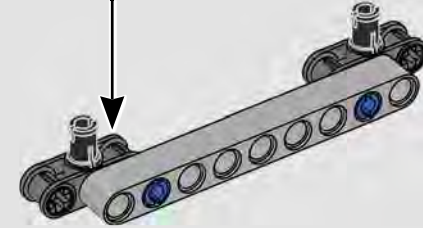
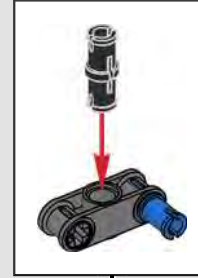

106

1:1

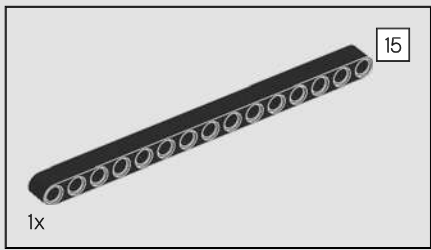

172

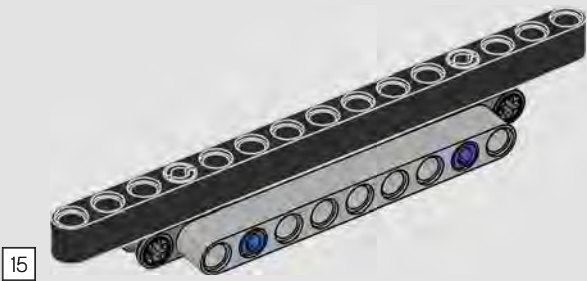

173



174

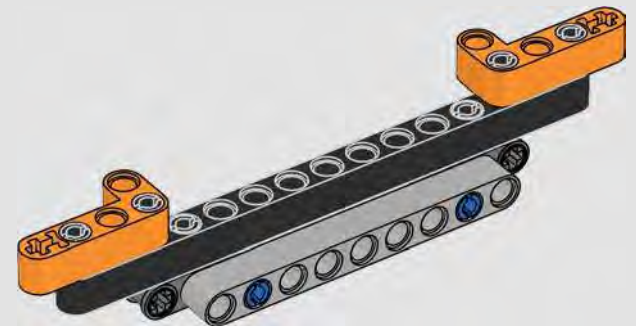

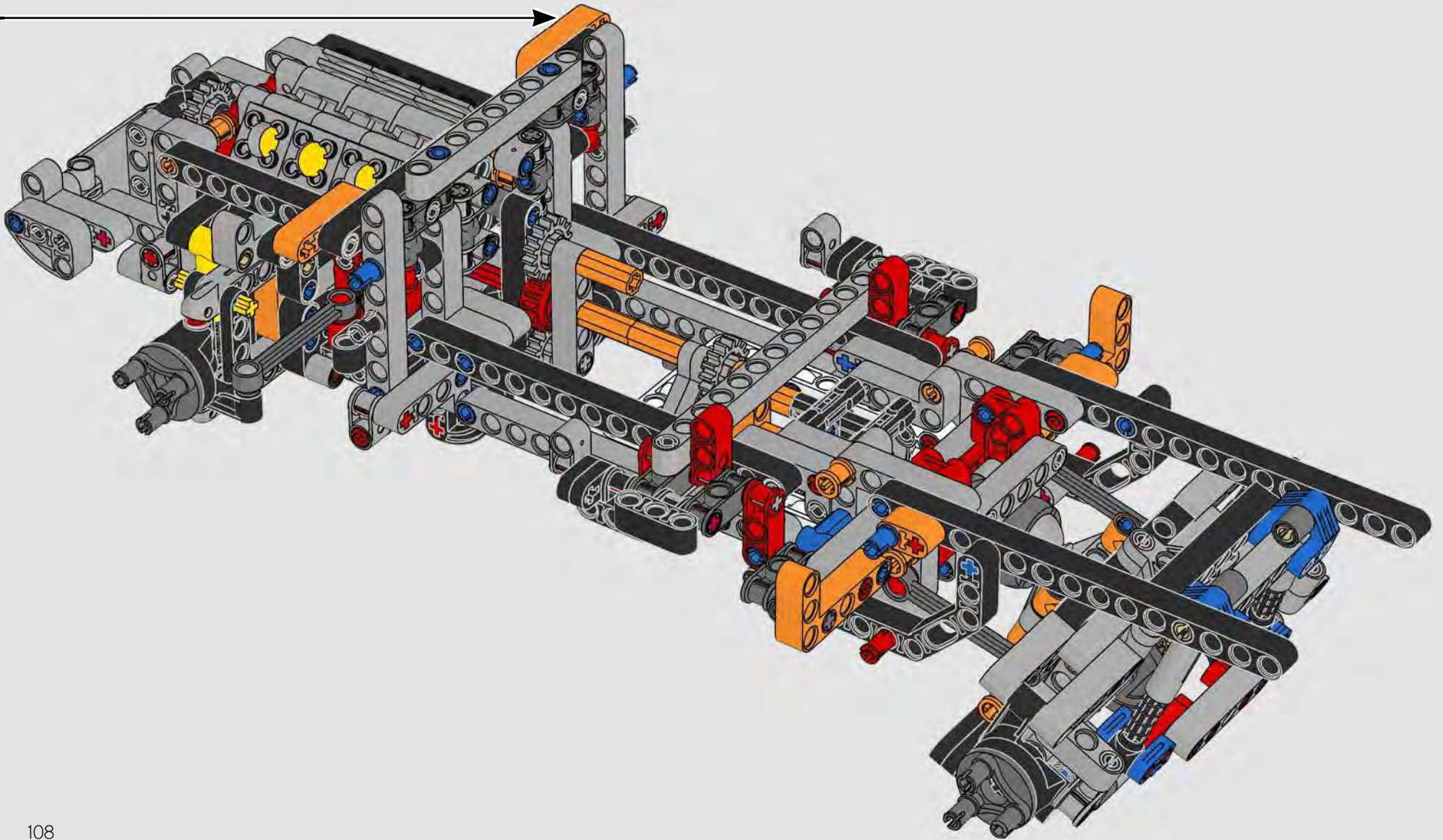



176

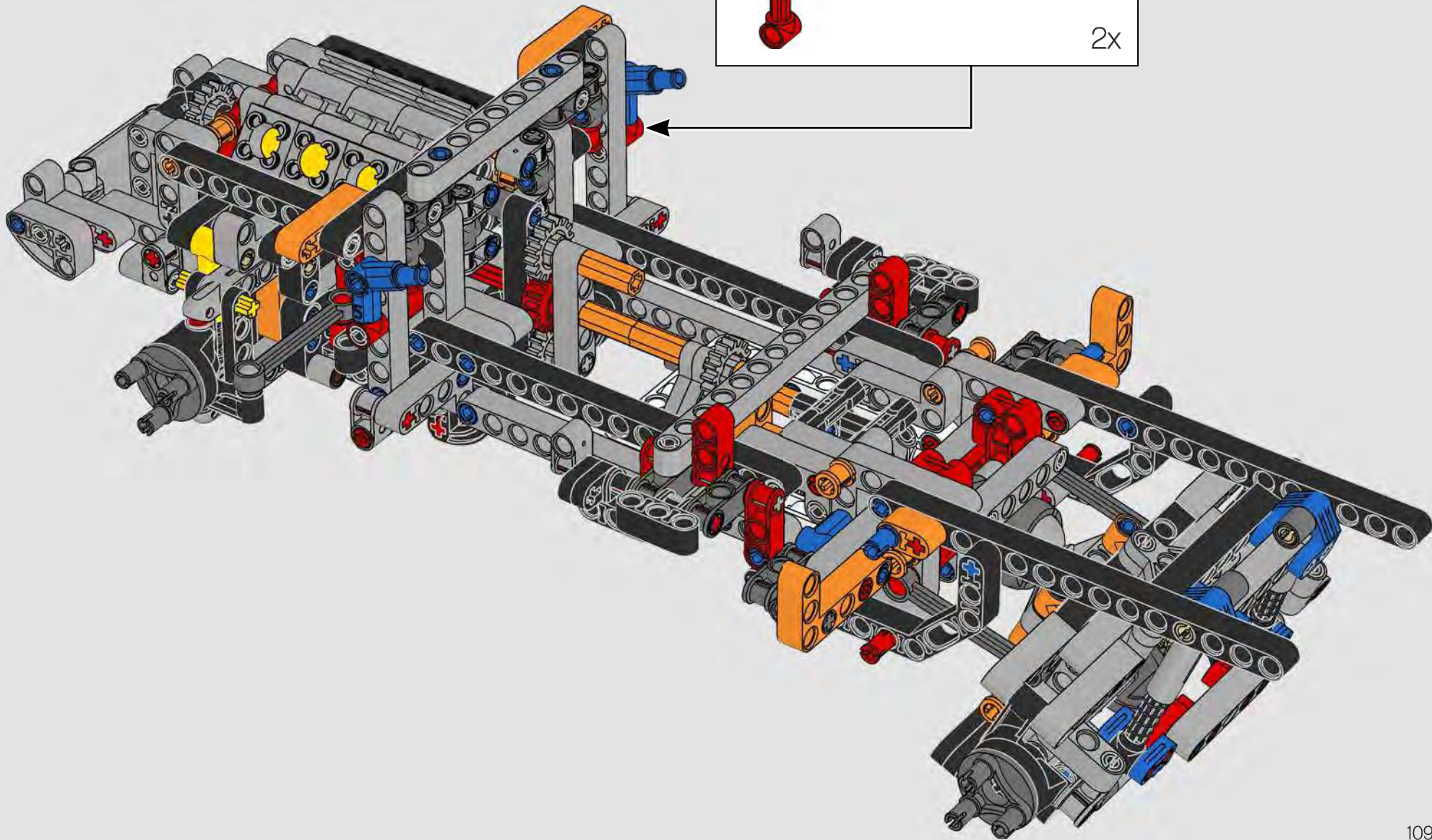
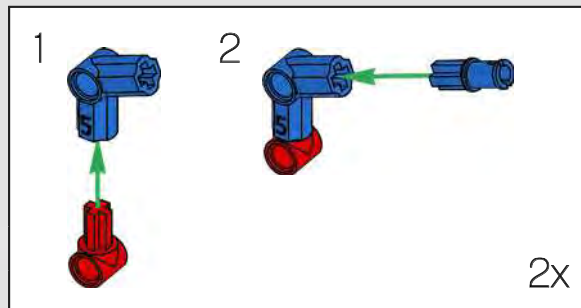

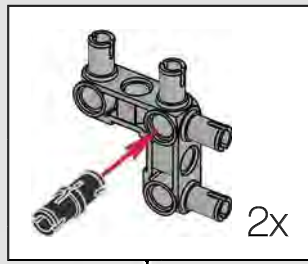
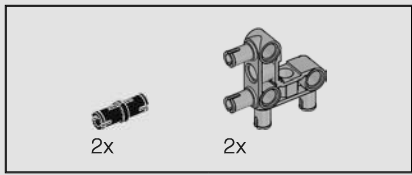

177

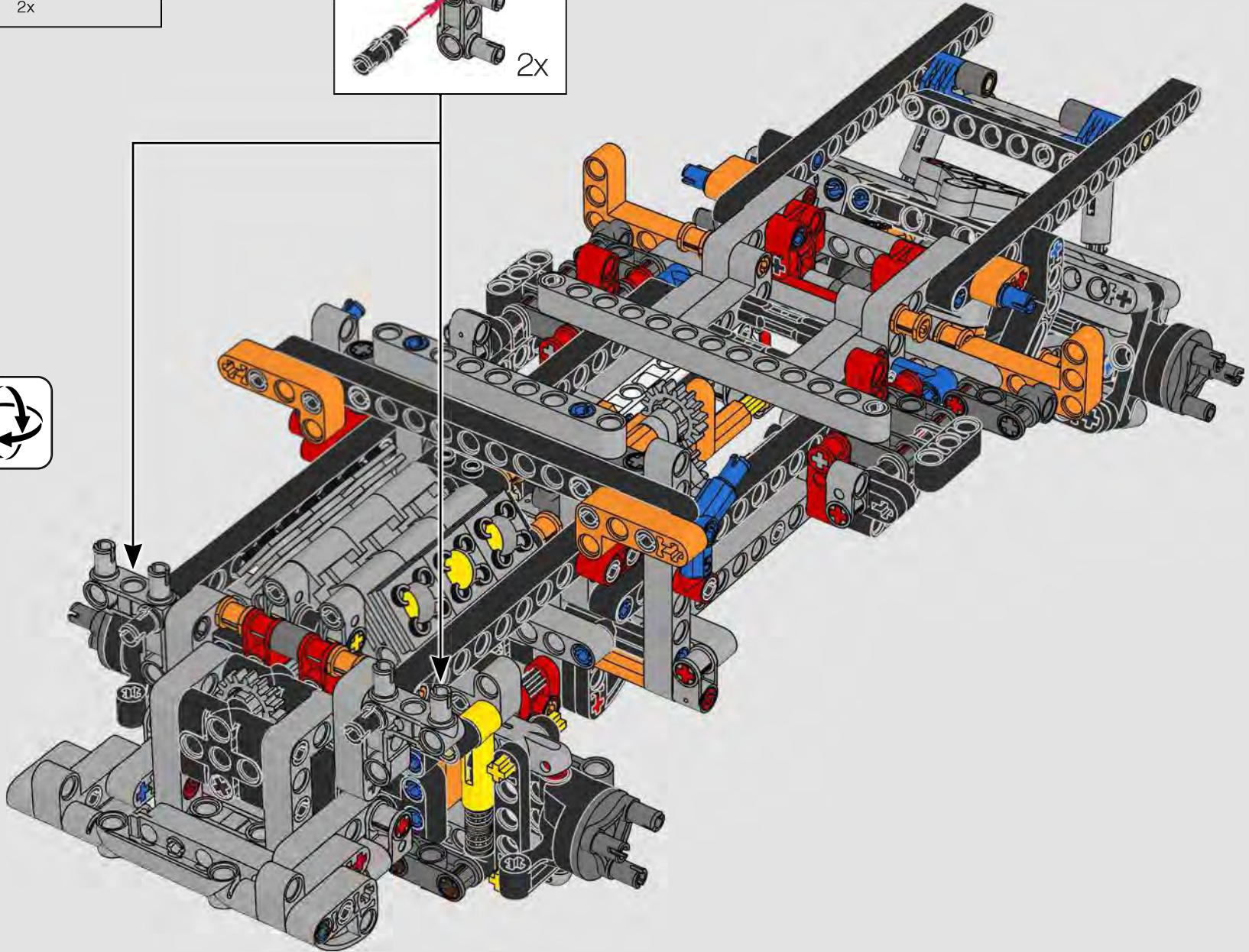



178

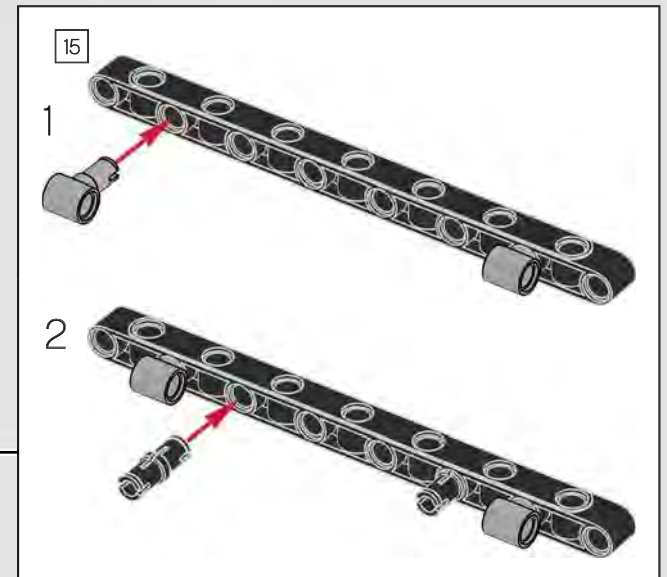
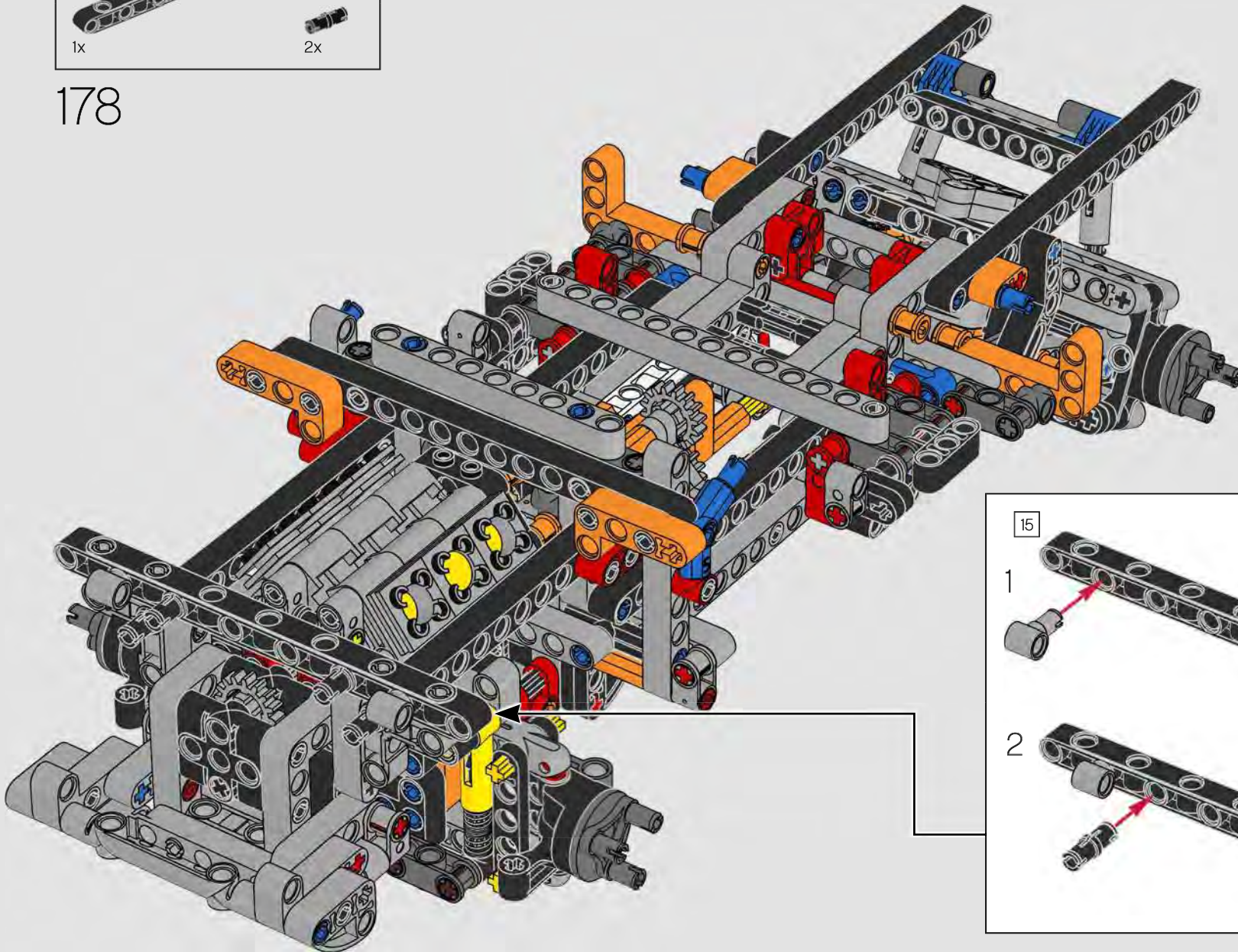

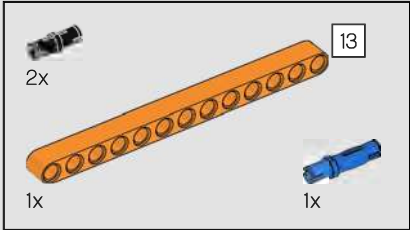
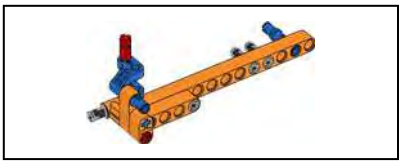

179

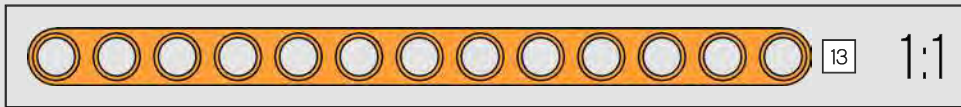
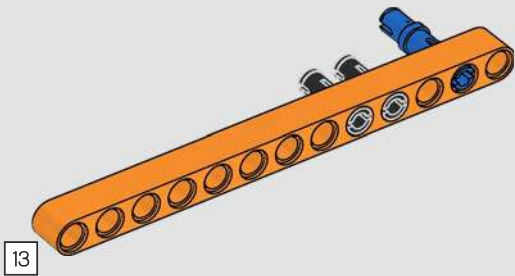

112

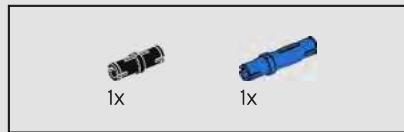

180

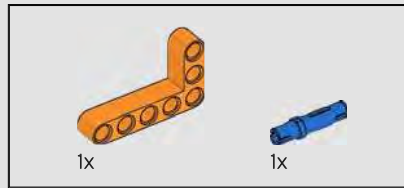
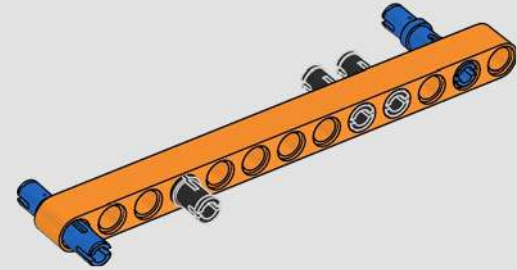

181

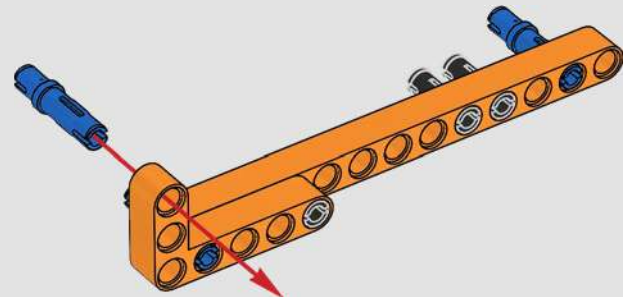





182

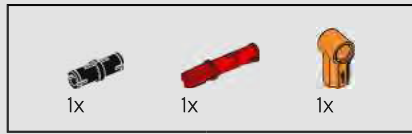
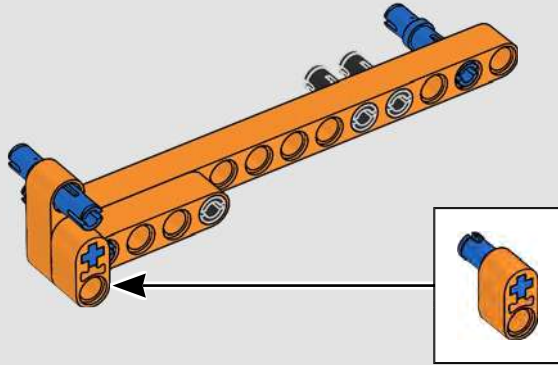

183

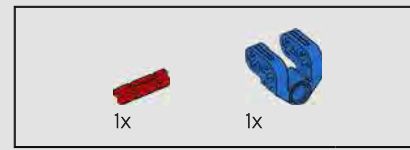
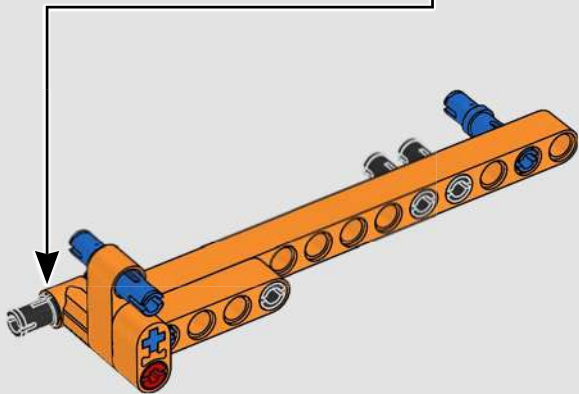
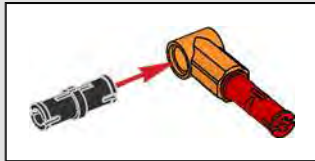

184

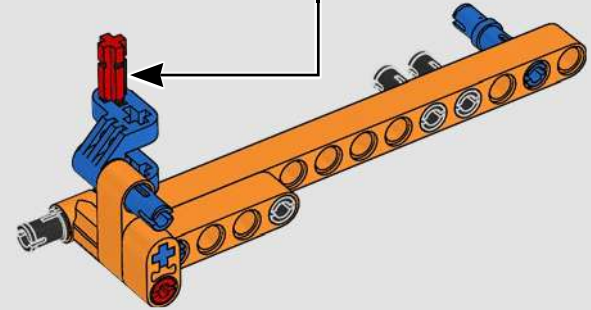
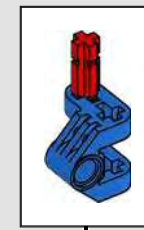

185

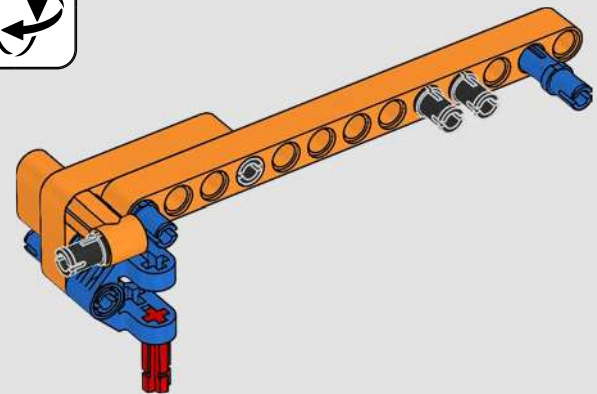
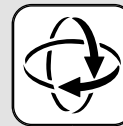

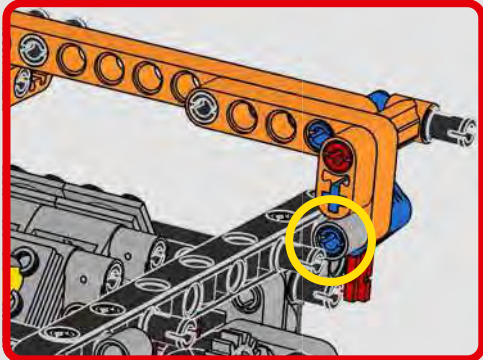
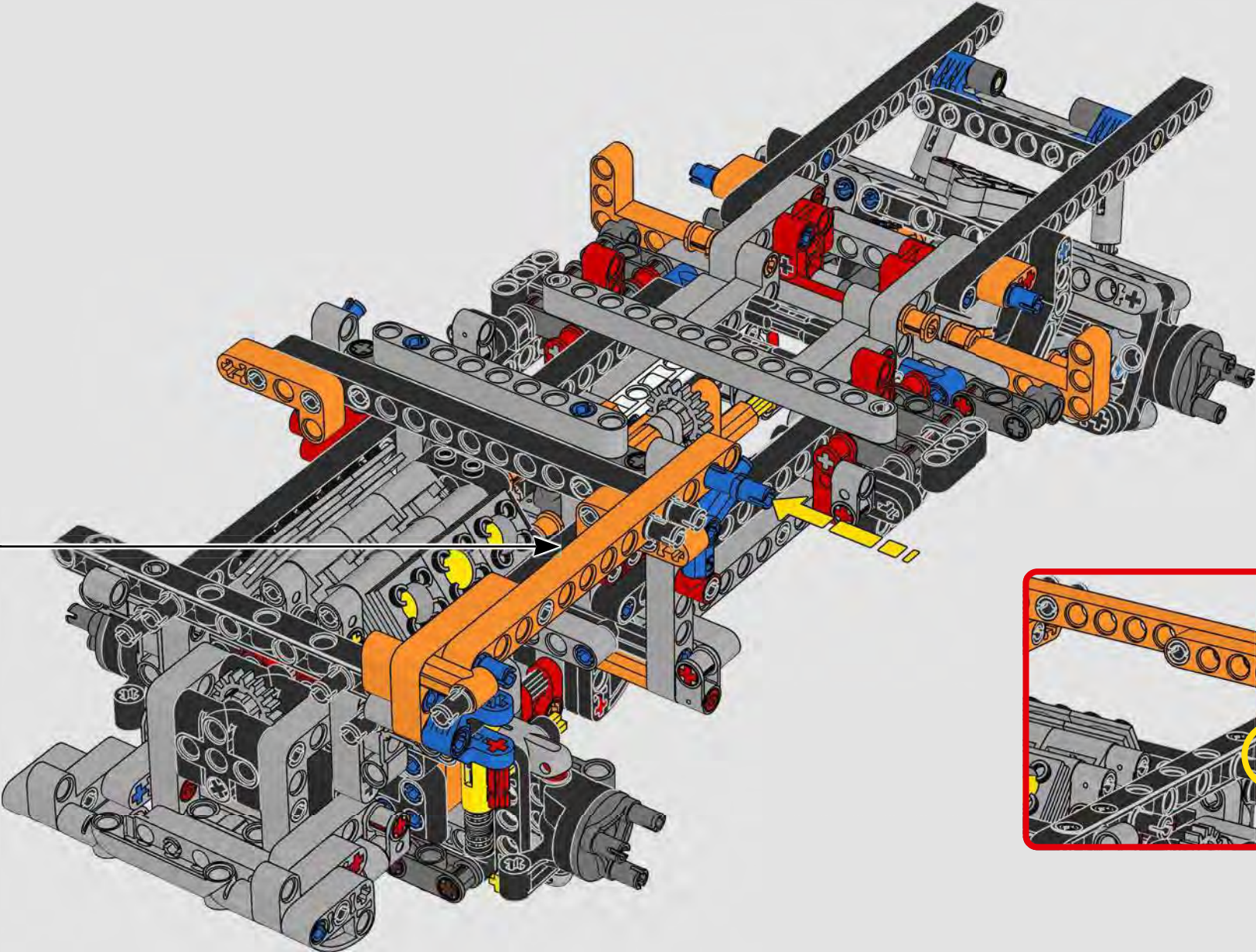

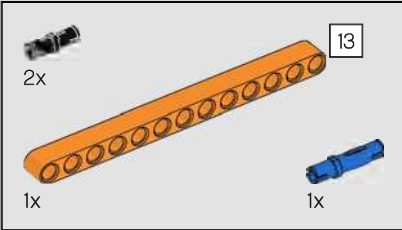
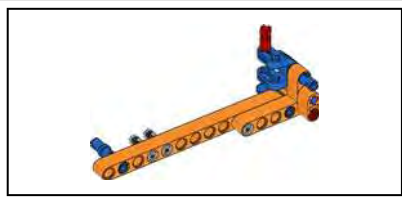

187

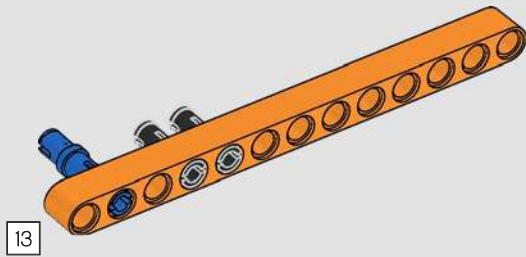

188

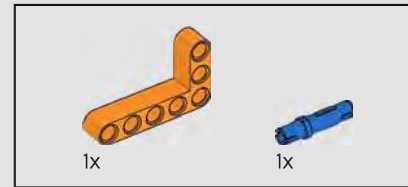
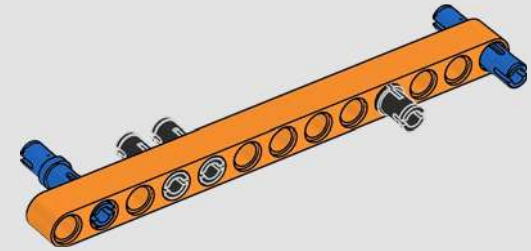

189

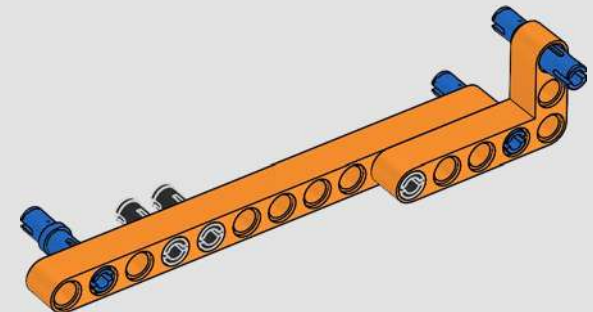



190

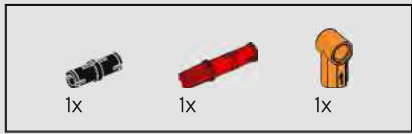
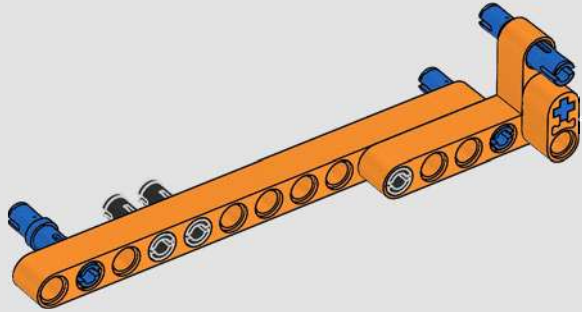

191

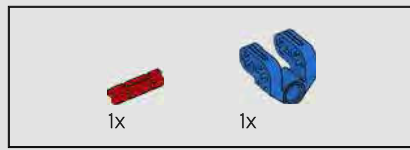
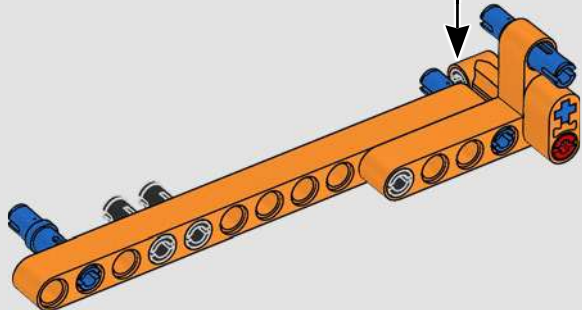
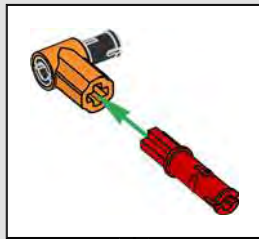

192

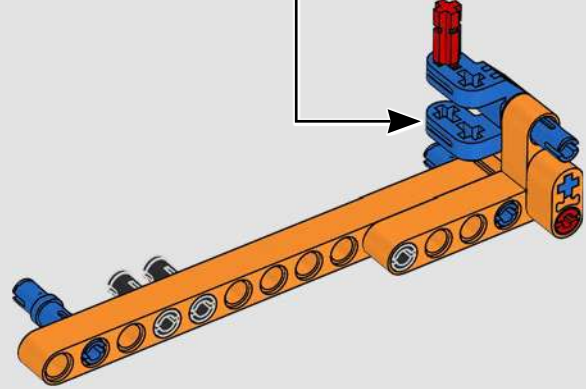
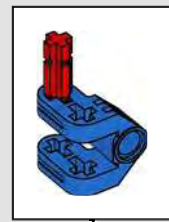

193

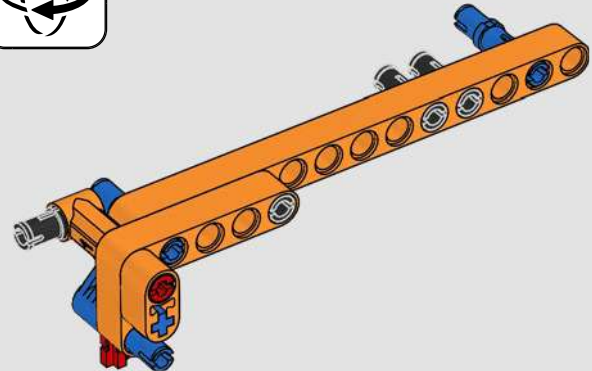

194

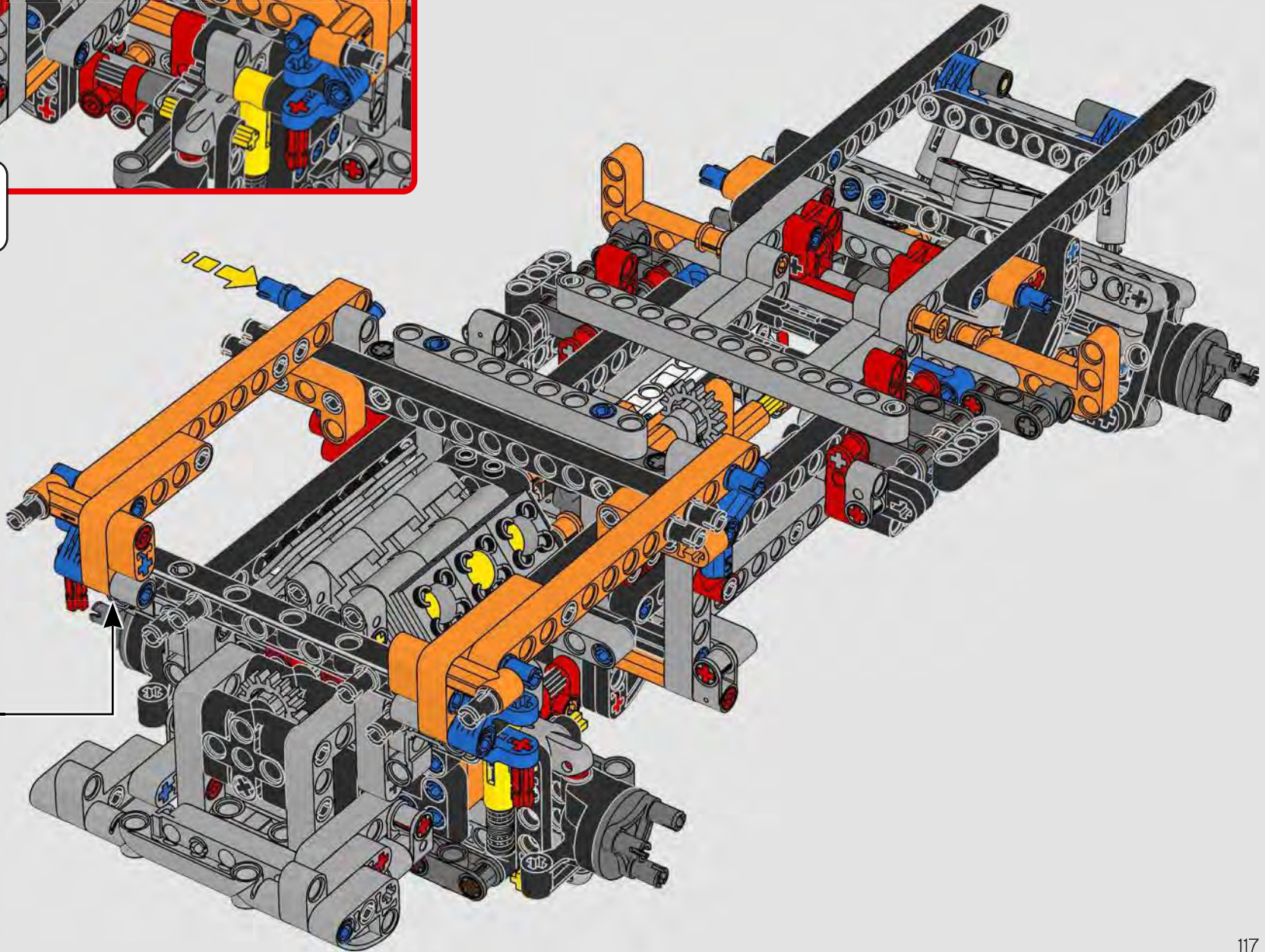
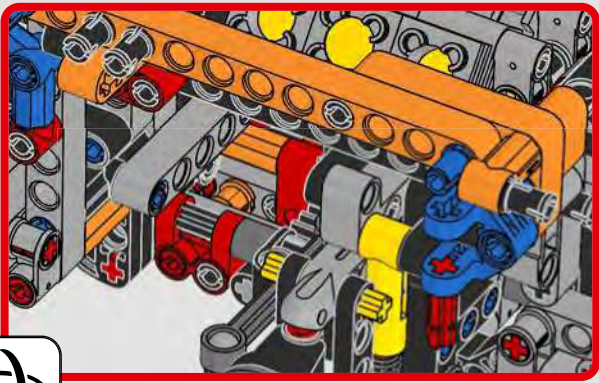

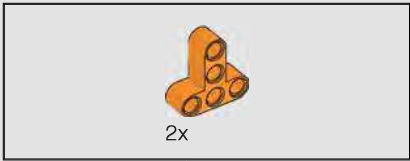

195

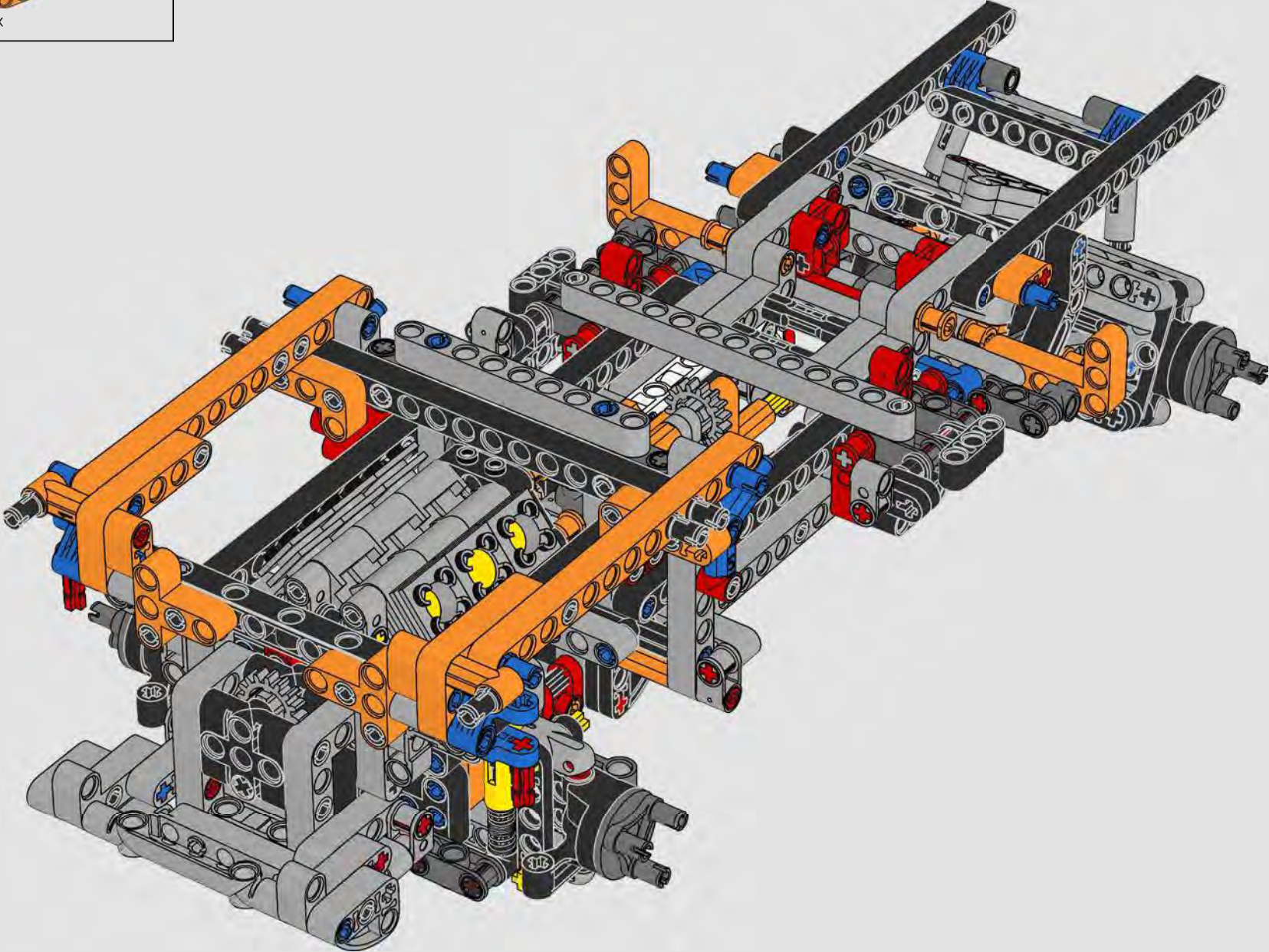



196

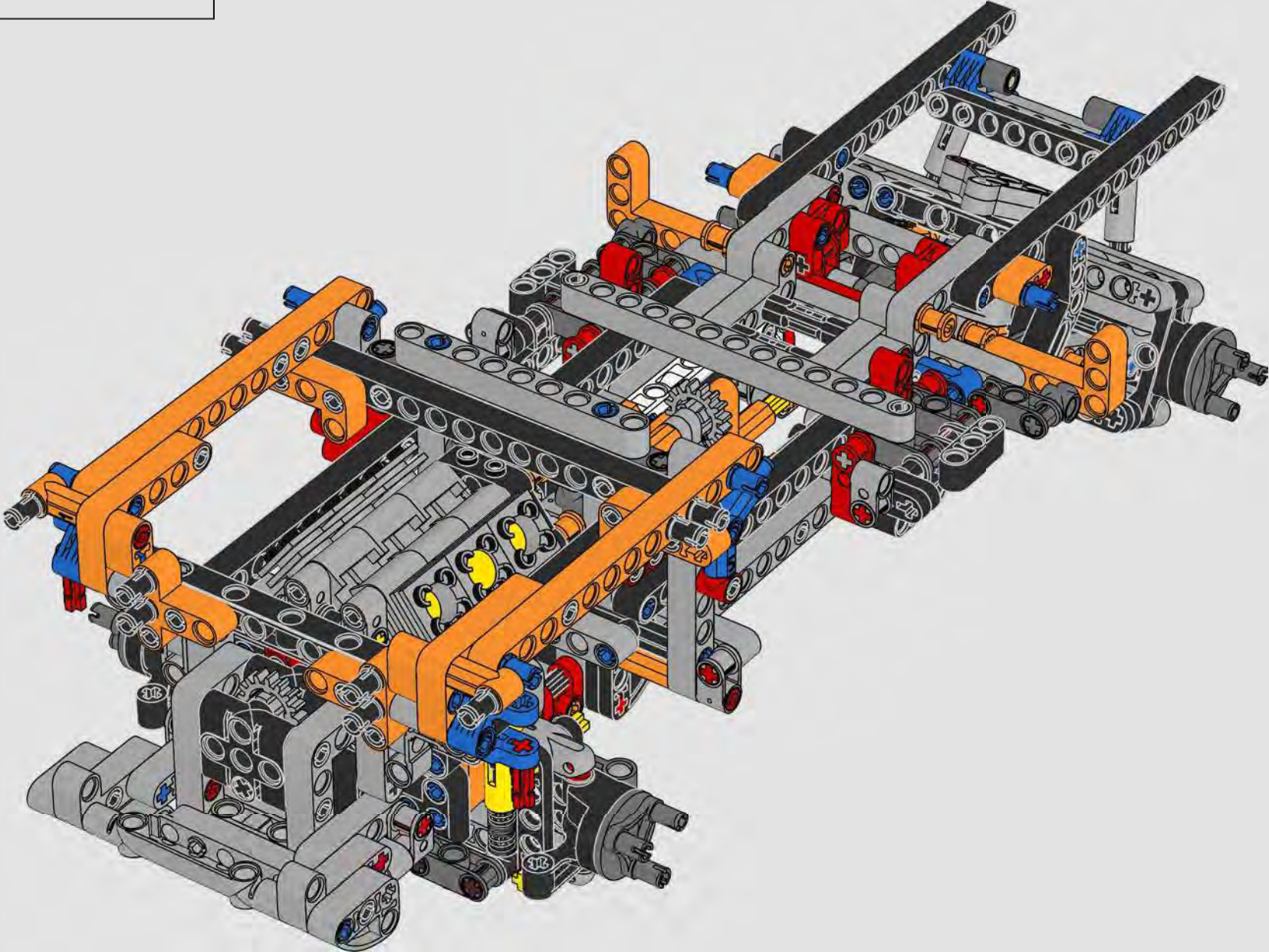

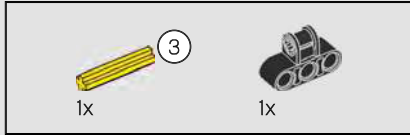
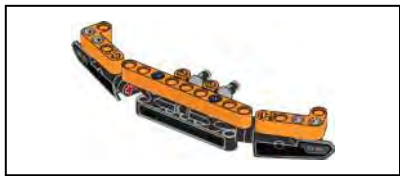

197



198

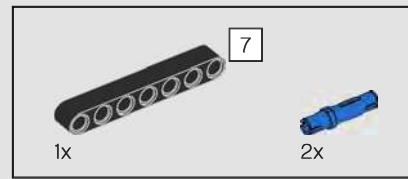
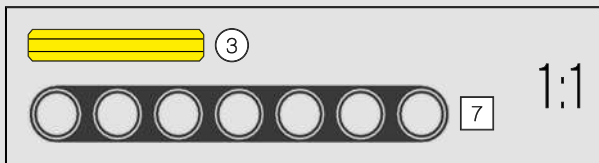
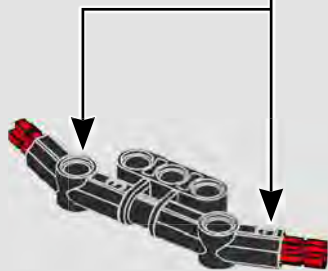

199

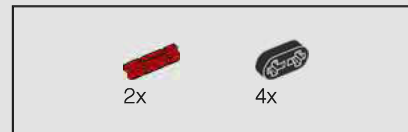
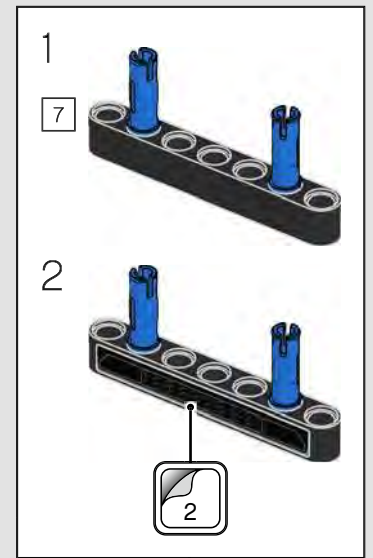

200

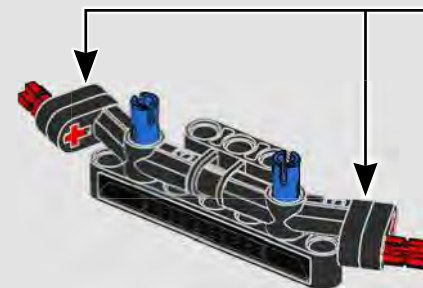



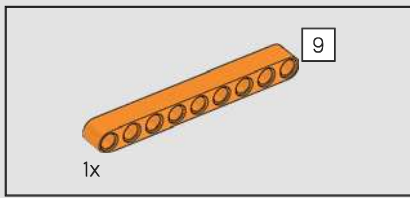

201

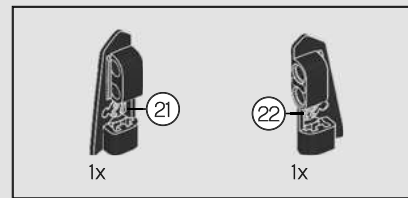
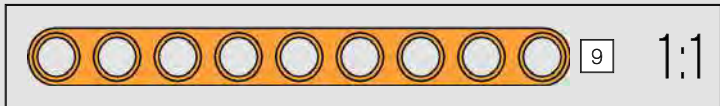
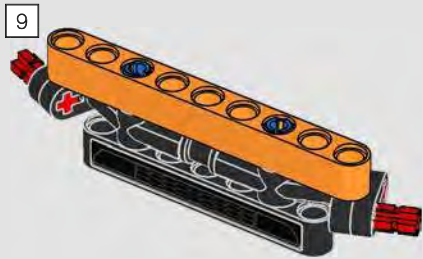

202

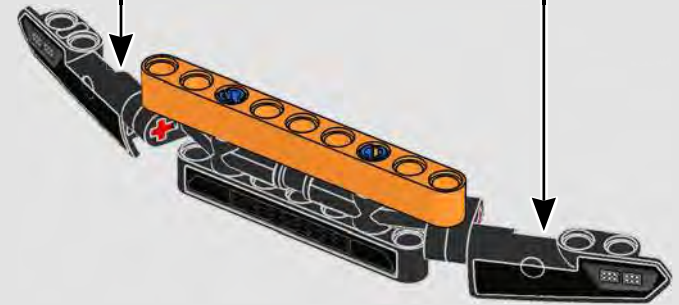
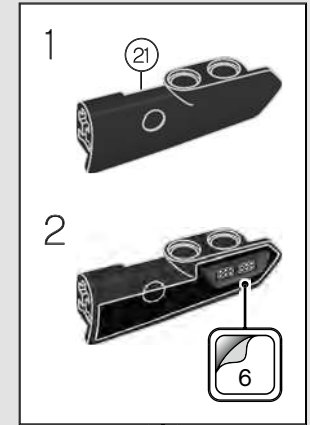
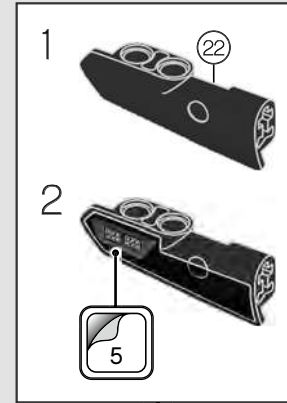



4x

203

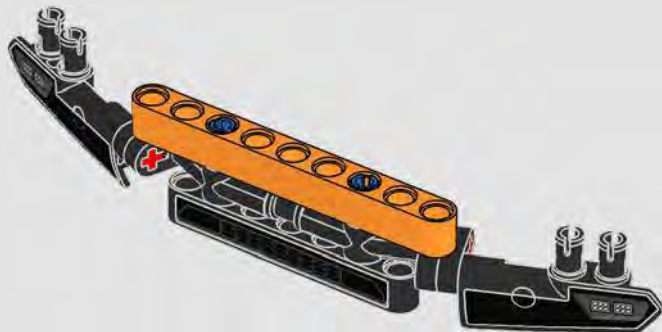

2x

204

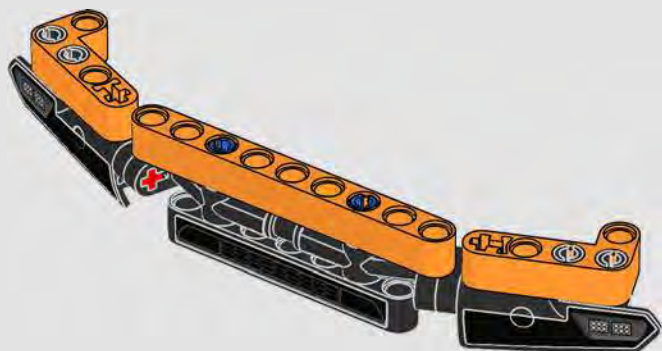

2x

205

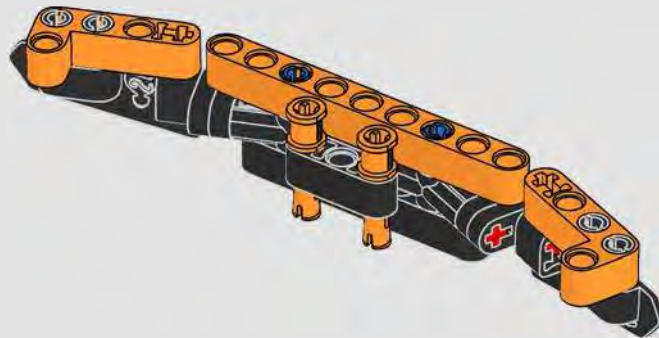



206

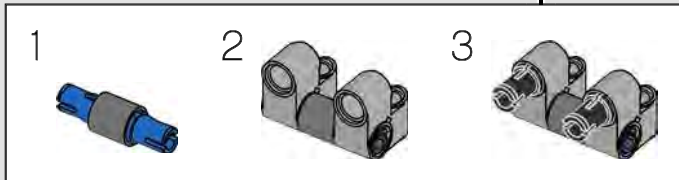
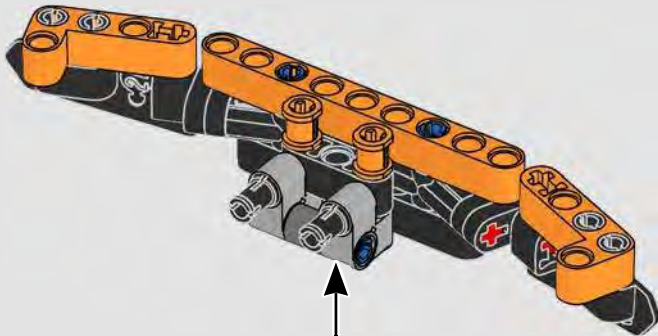

207

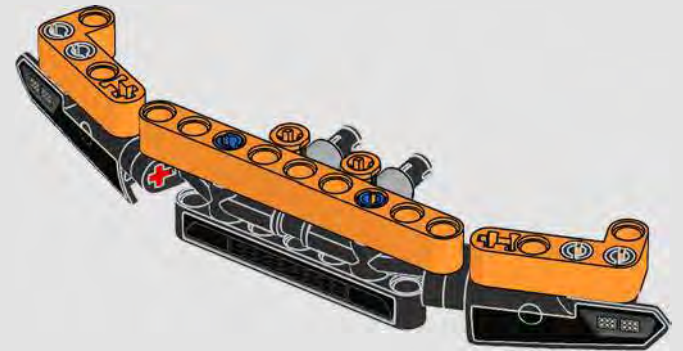
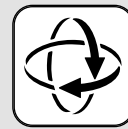

208

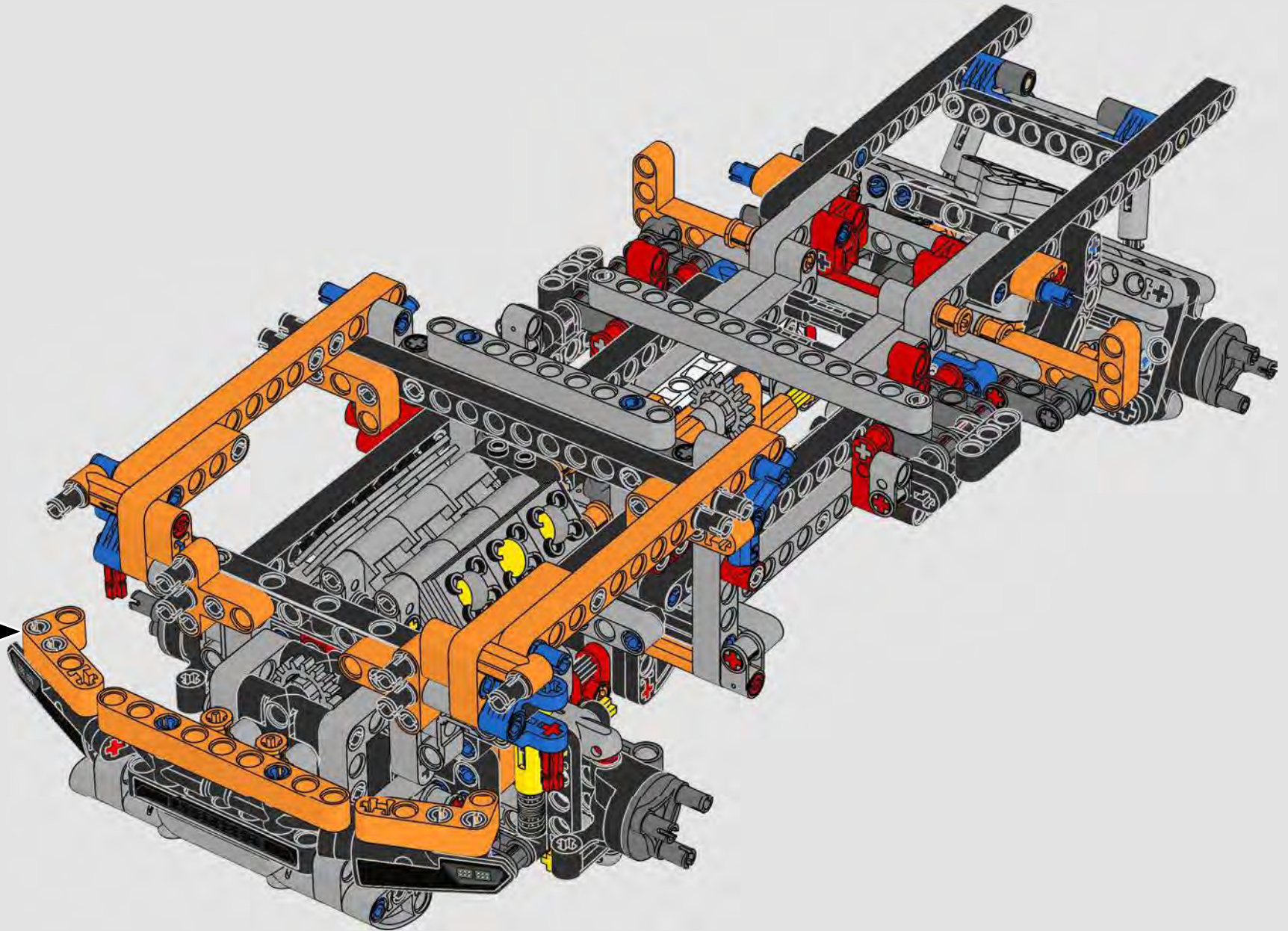

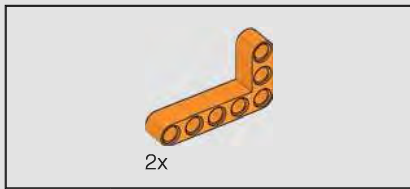

209

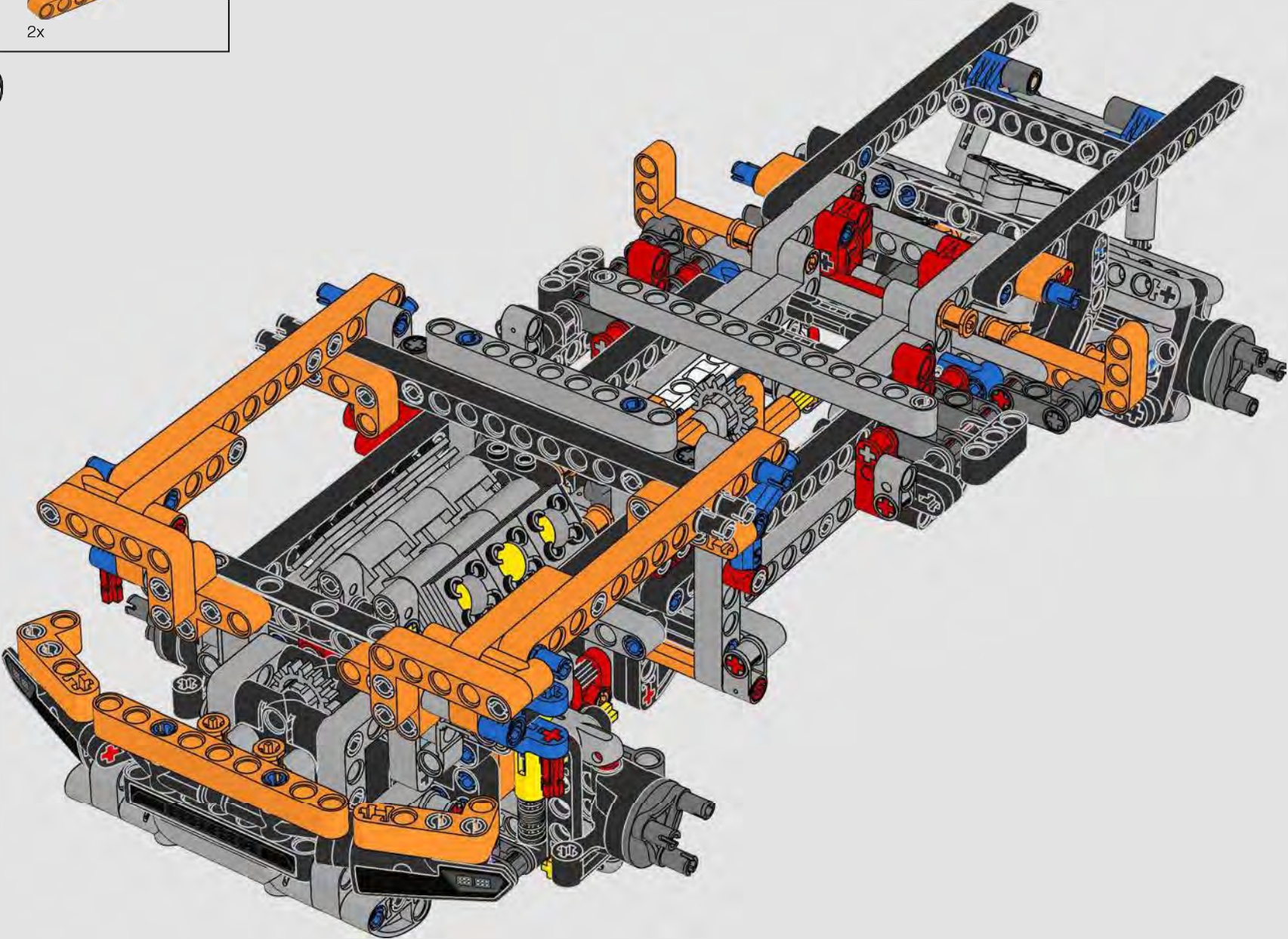

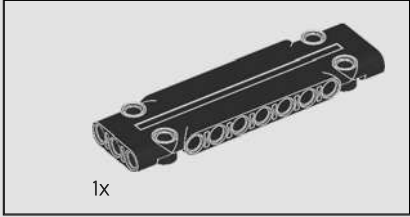

210

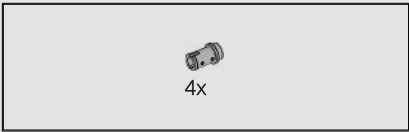
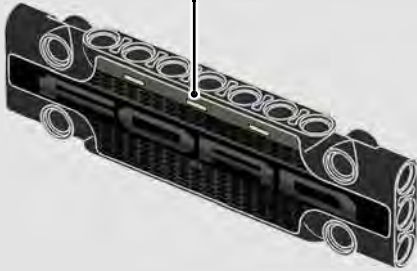

211



*The Raptor is fitted with its own grille, replacing the Ford Blue Oval emblem with large "FORD" lettering.*

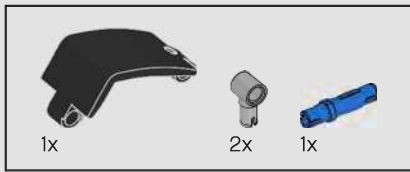

212

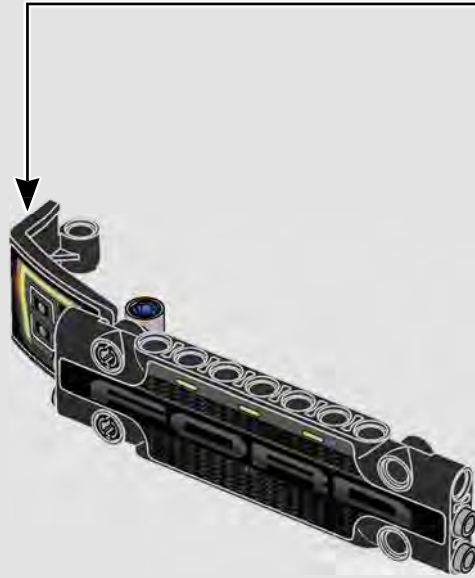
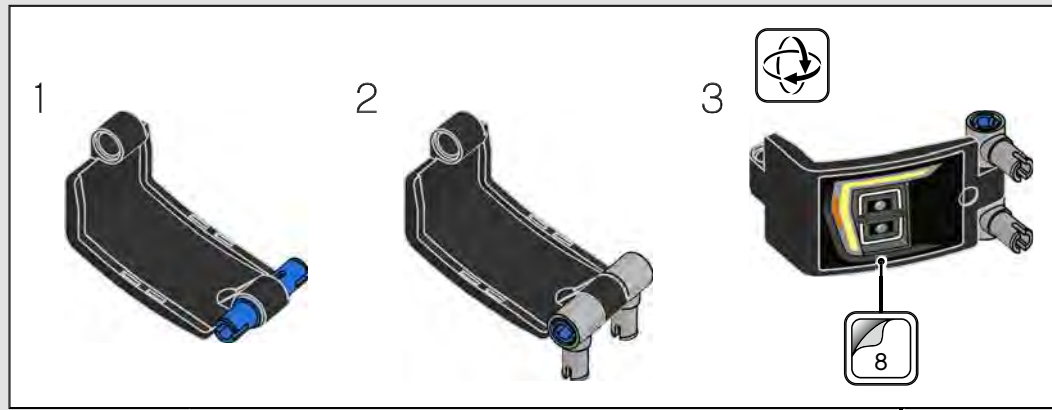

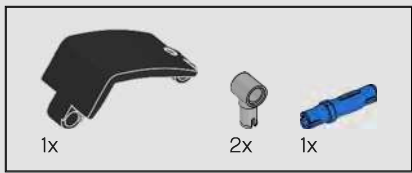

213

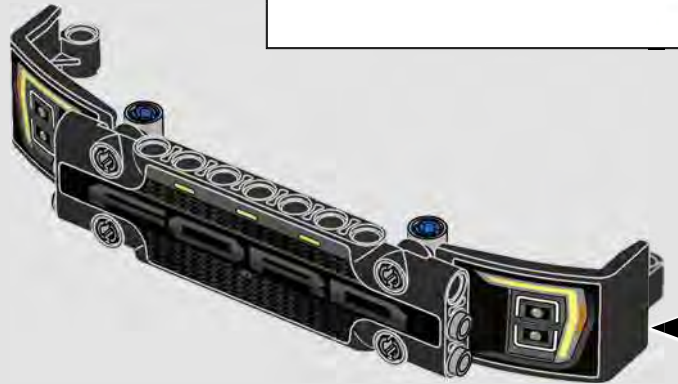
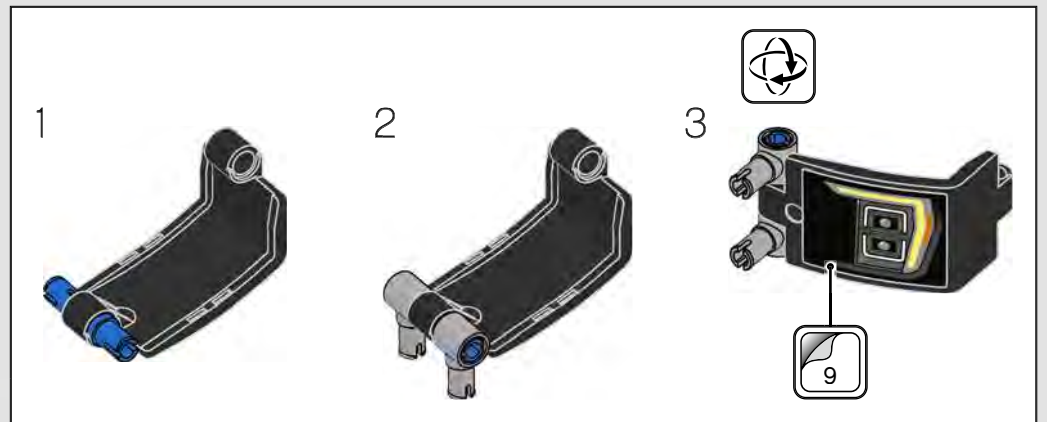

214

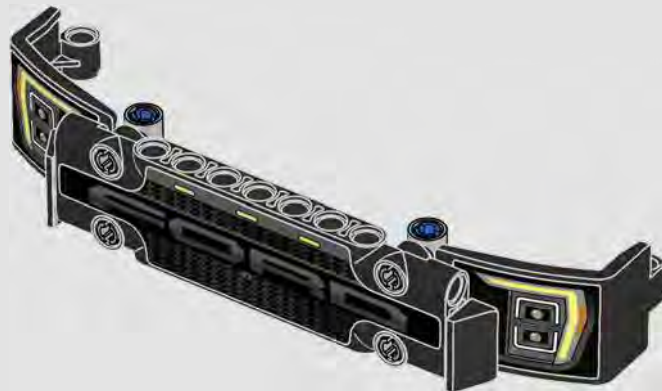



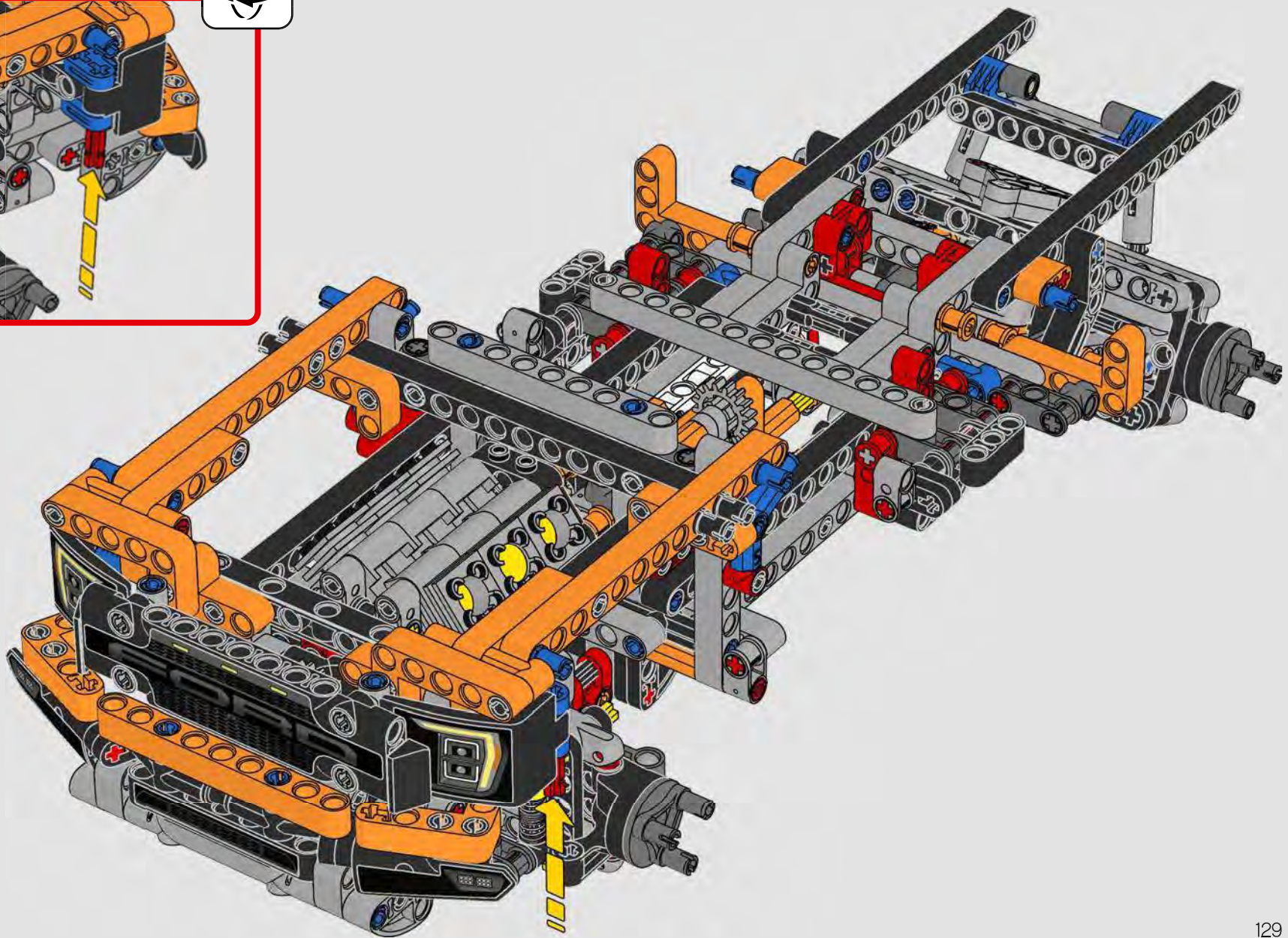
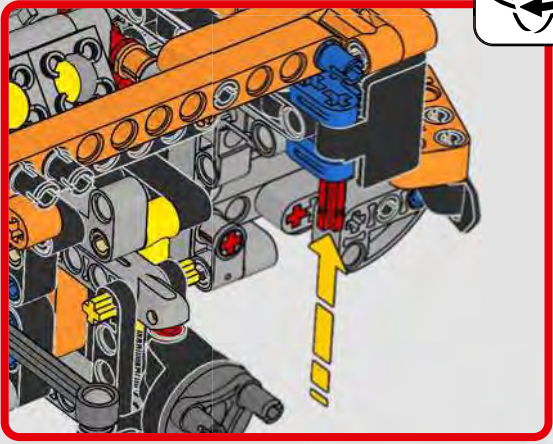

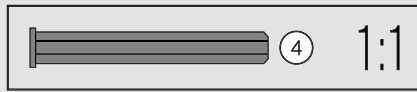
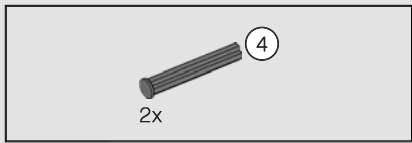

216

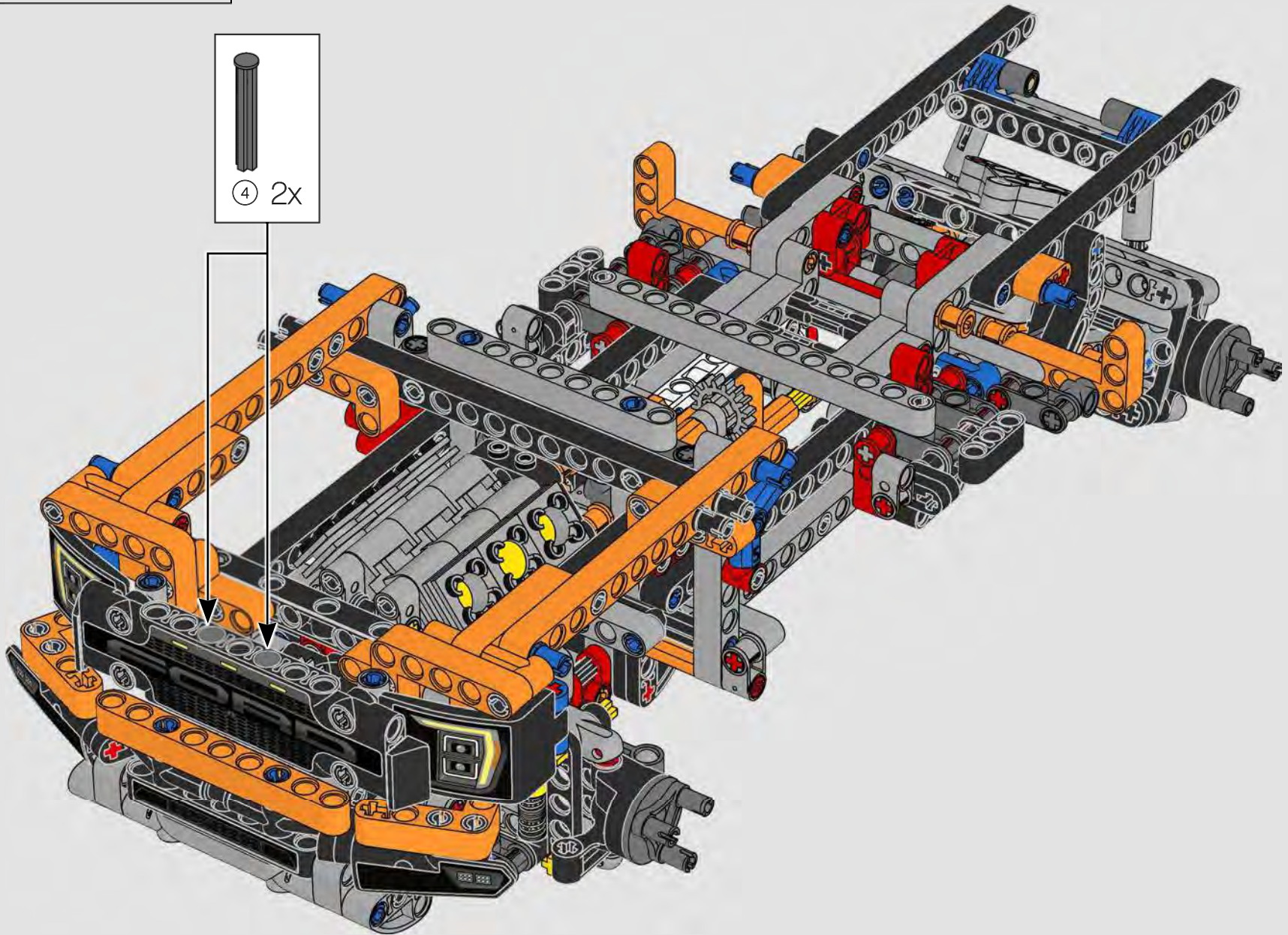
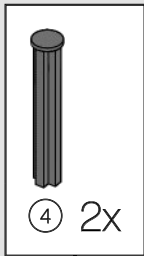

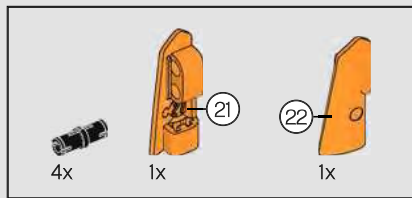

217

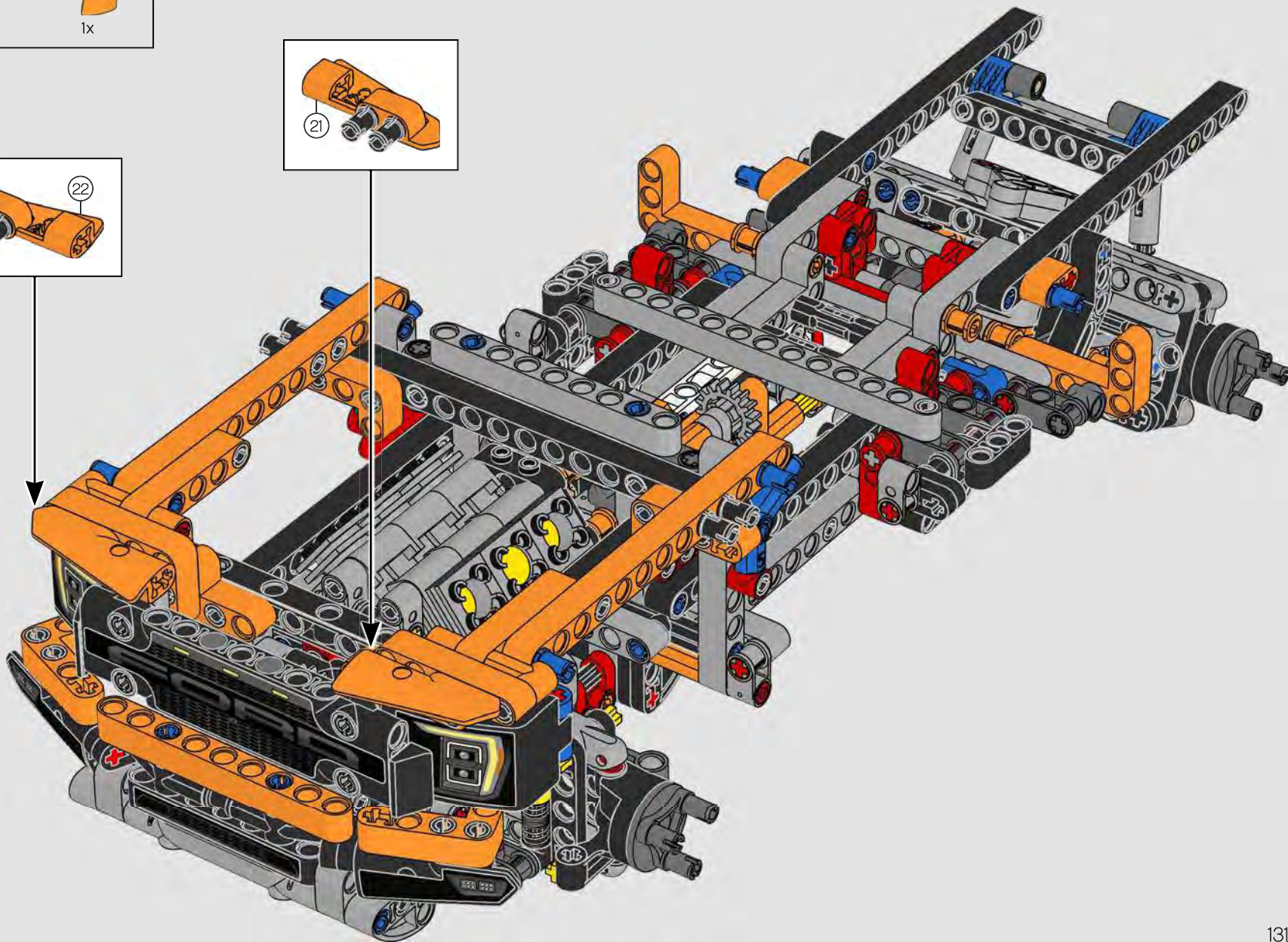
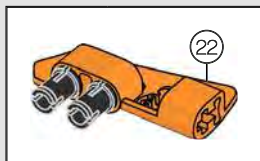
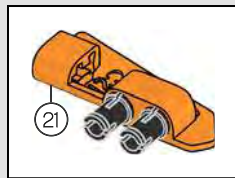

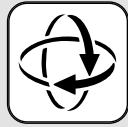
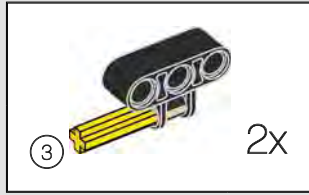
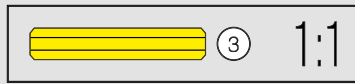

218

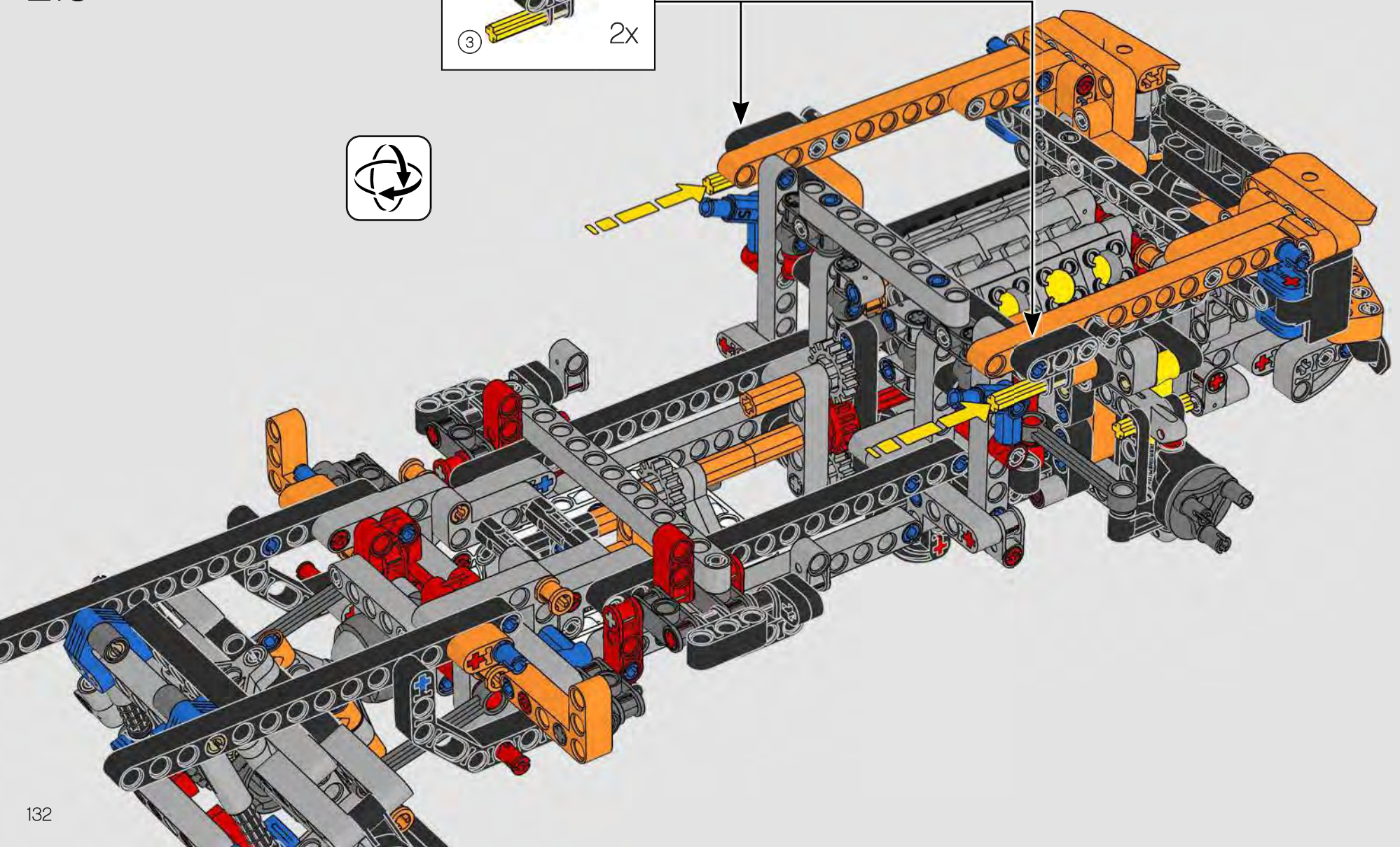

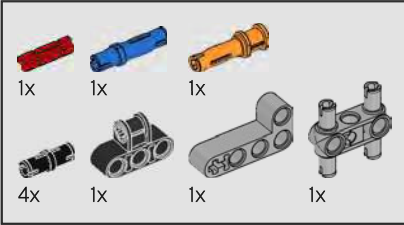

219

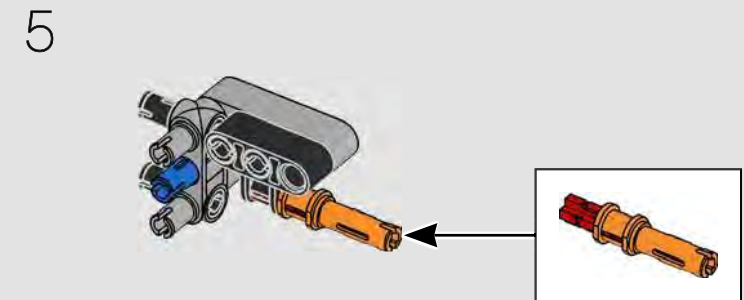
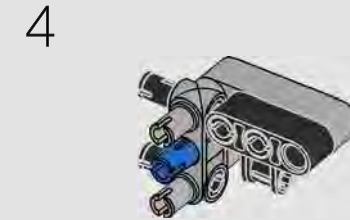
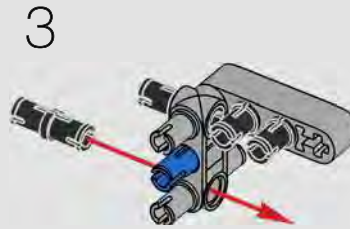
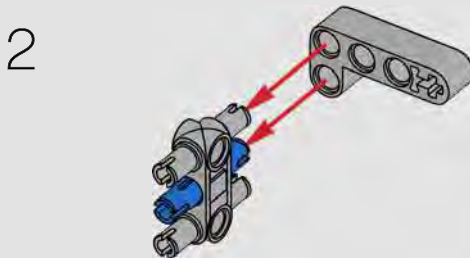
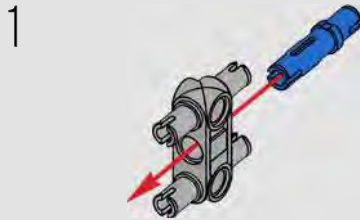

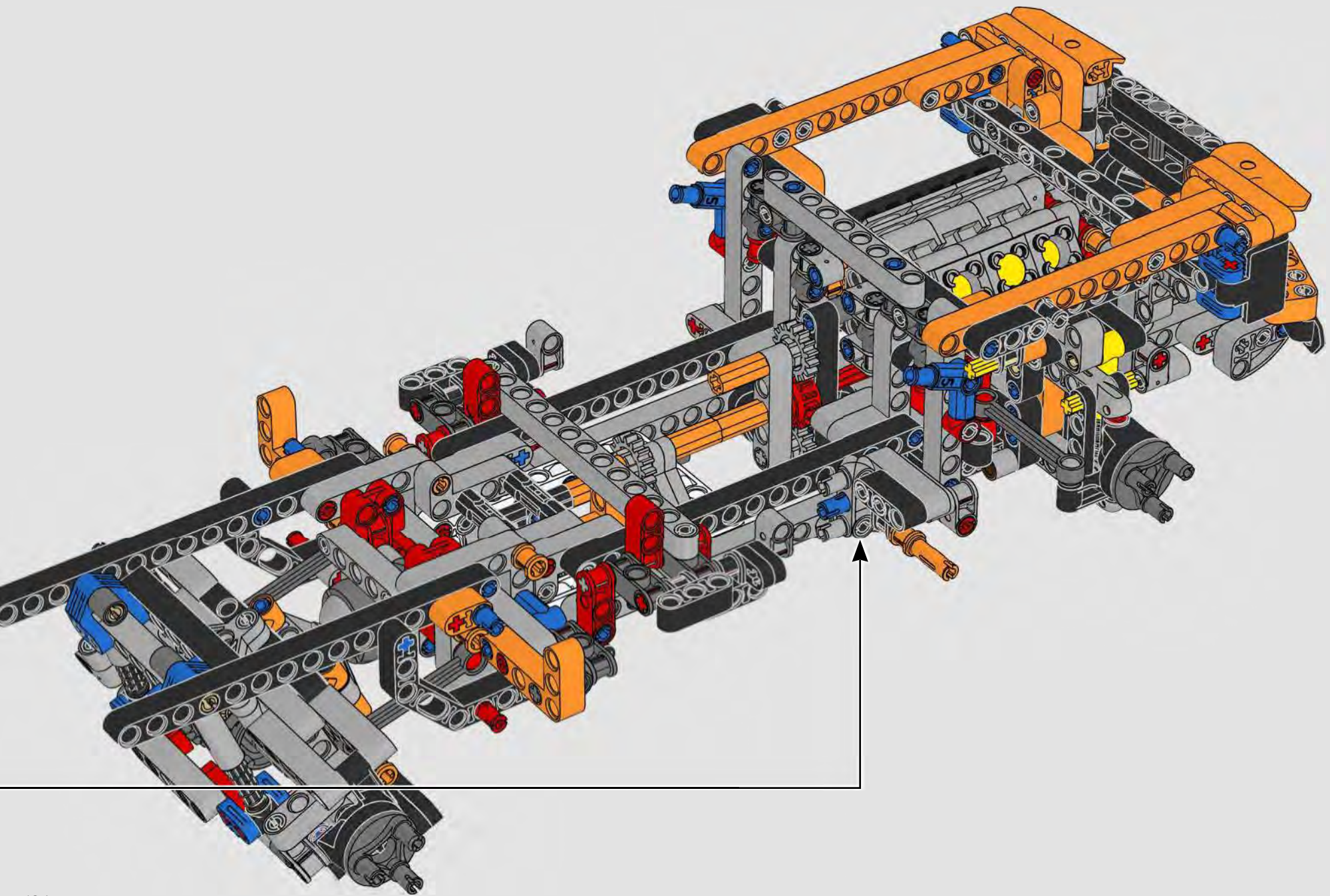

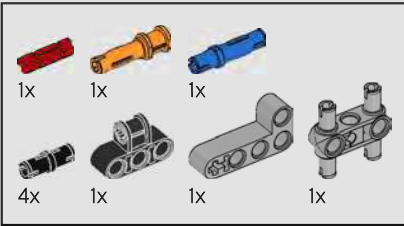

220

1

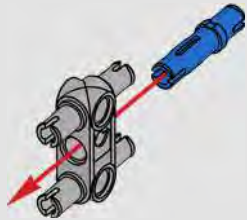

2

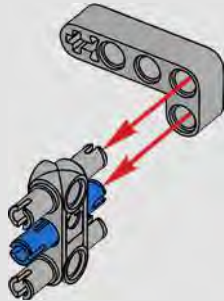

3

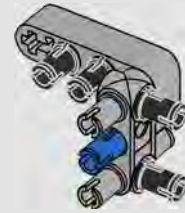

4

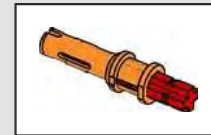
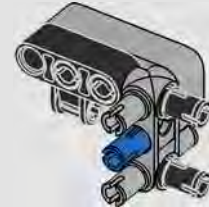

5

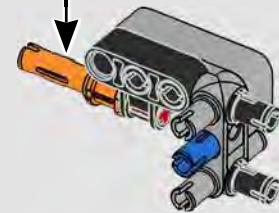

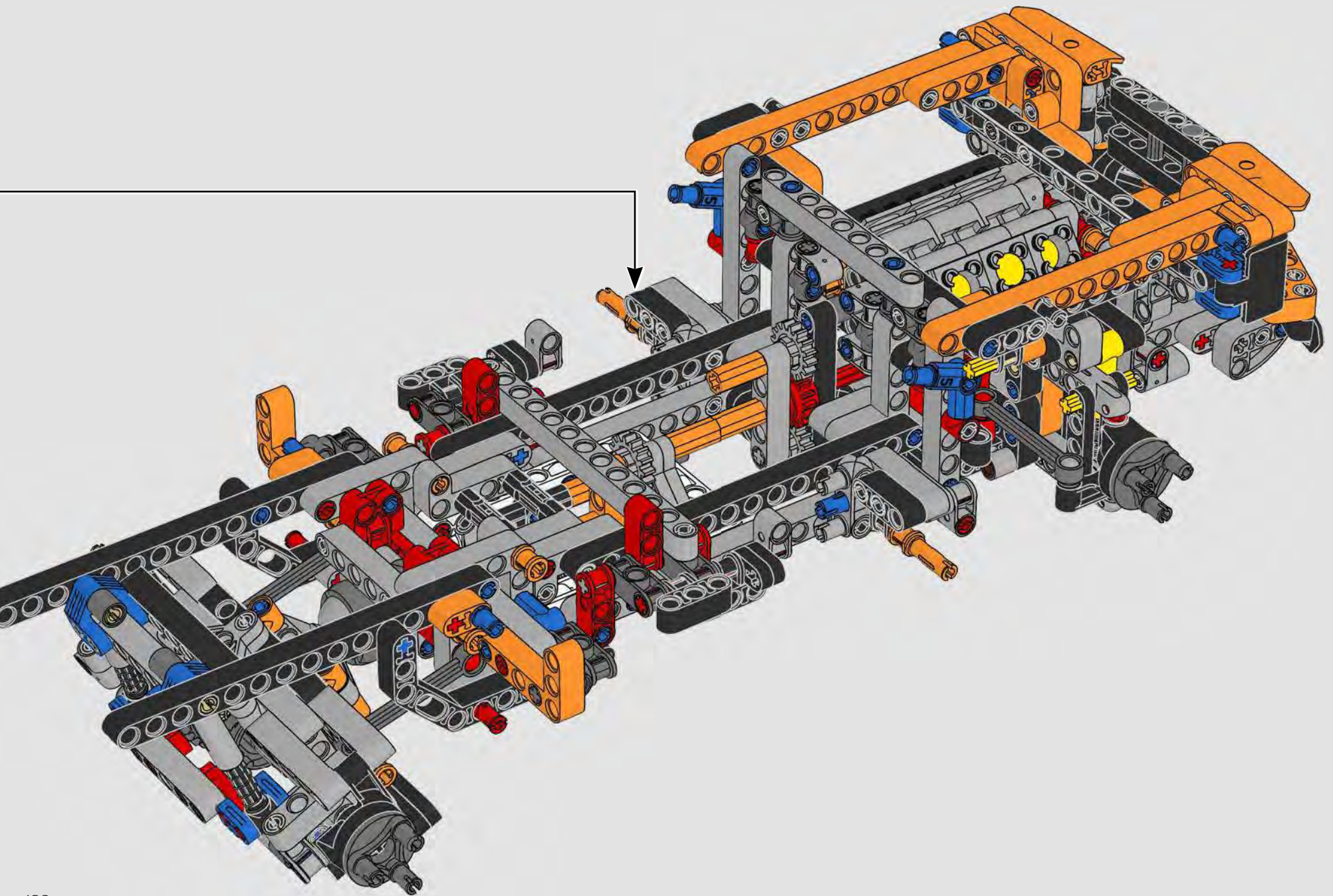



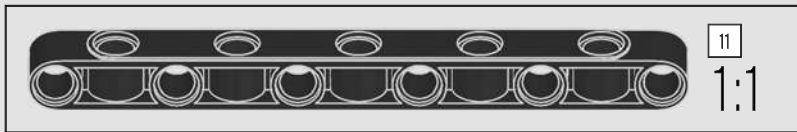
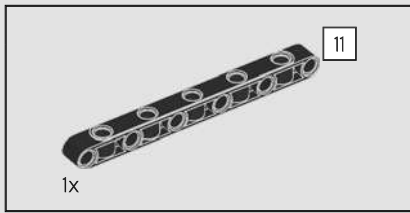

221

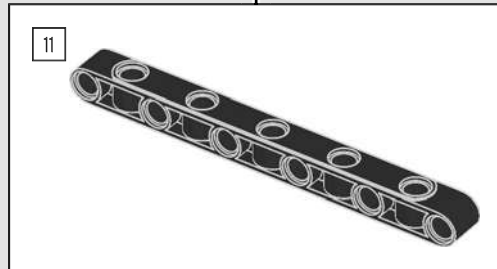
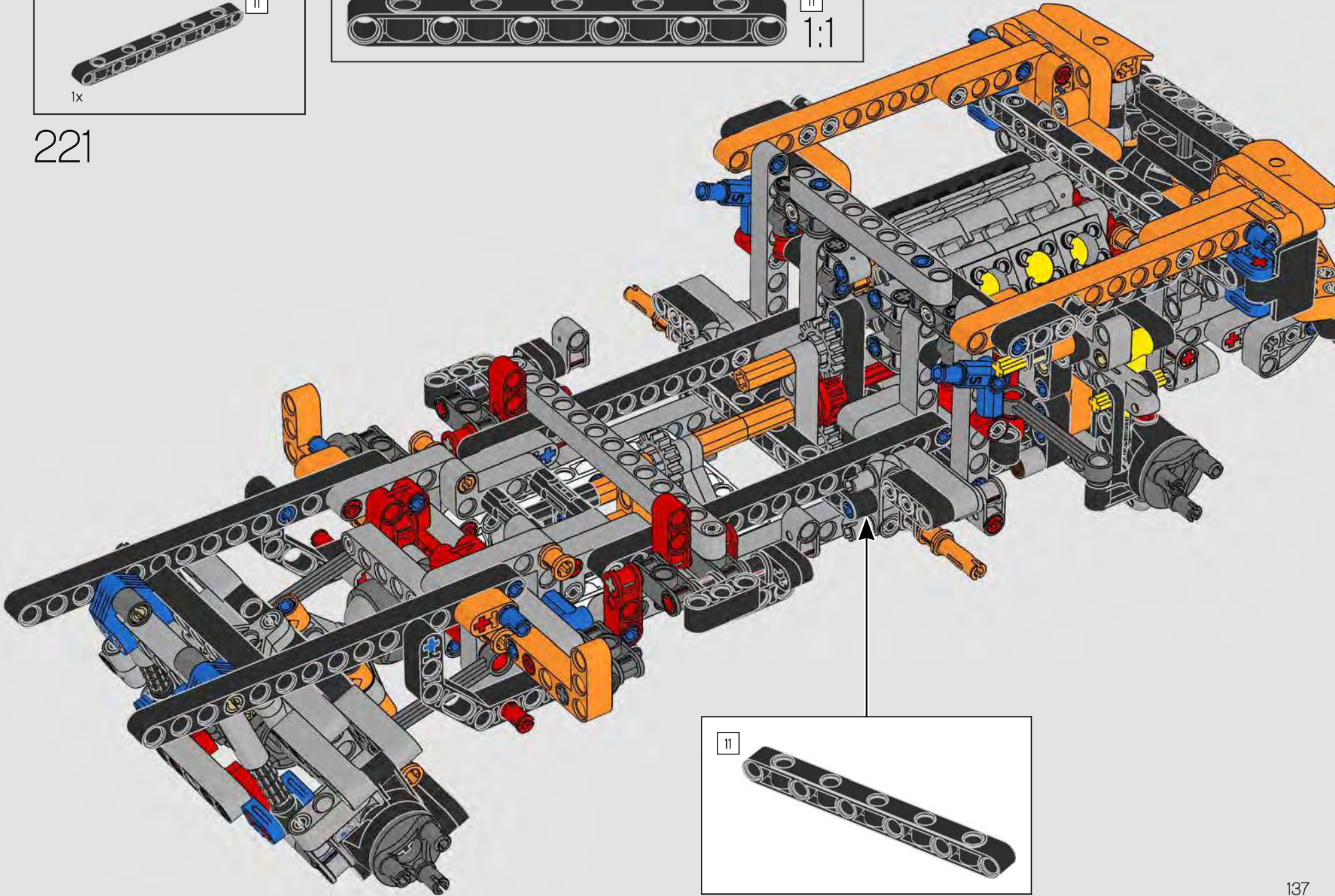

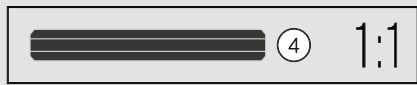
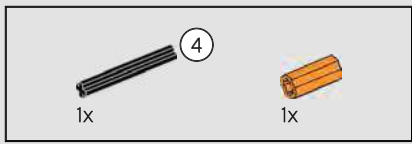

222

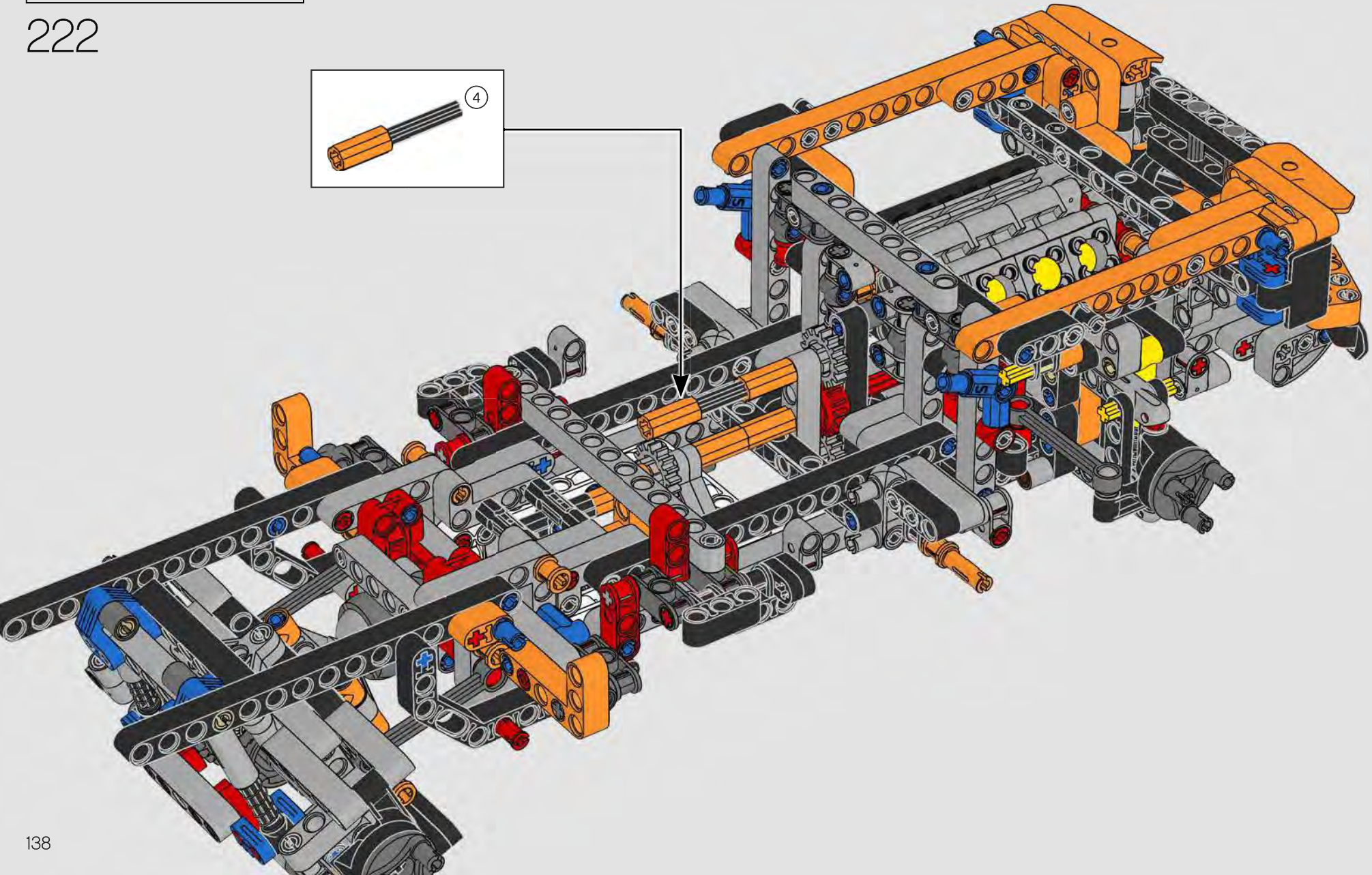
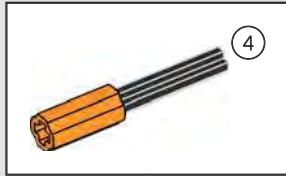

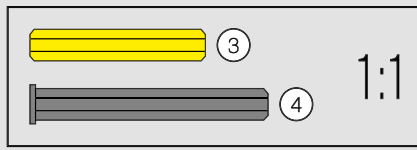
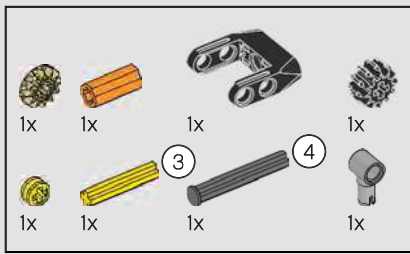

223

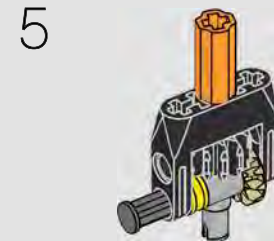
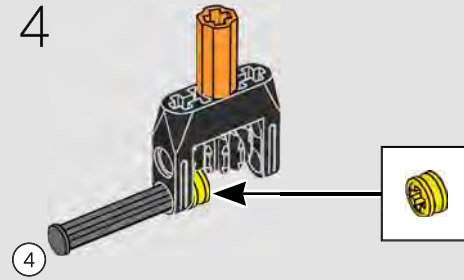
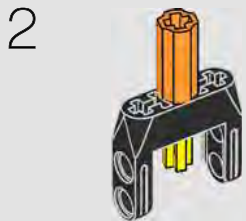
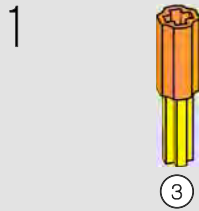

224

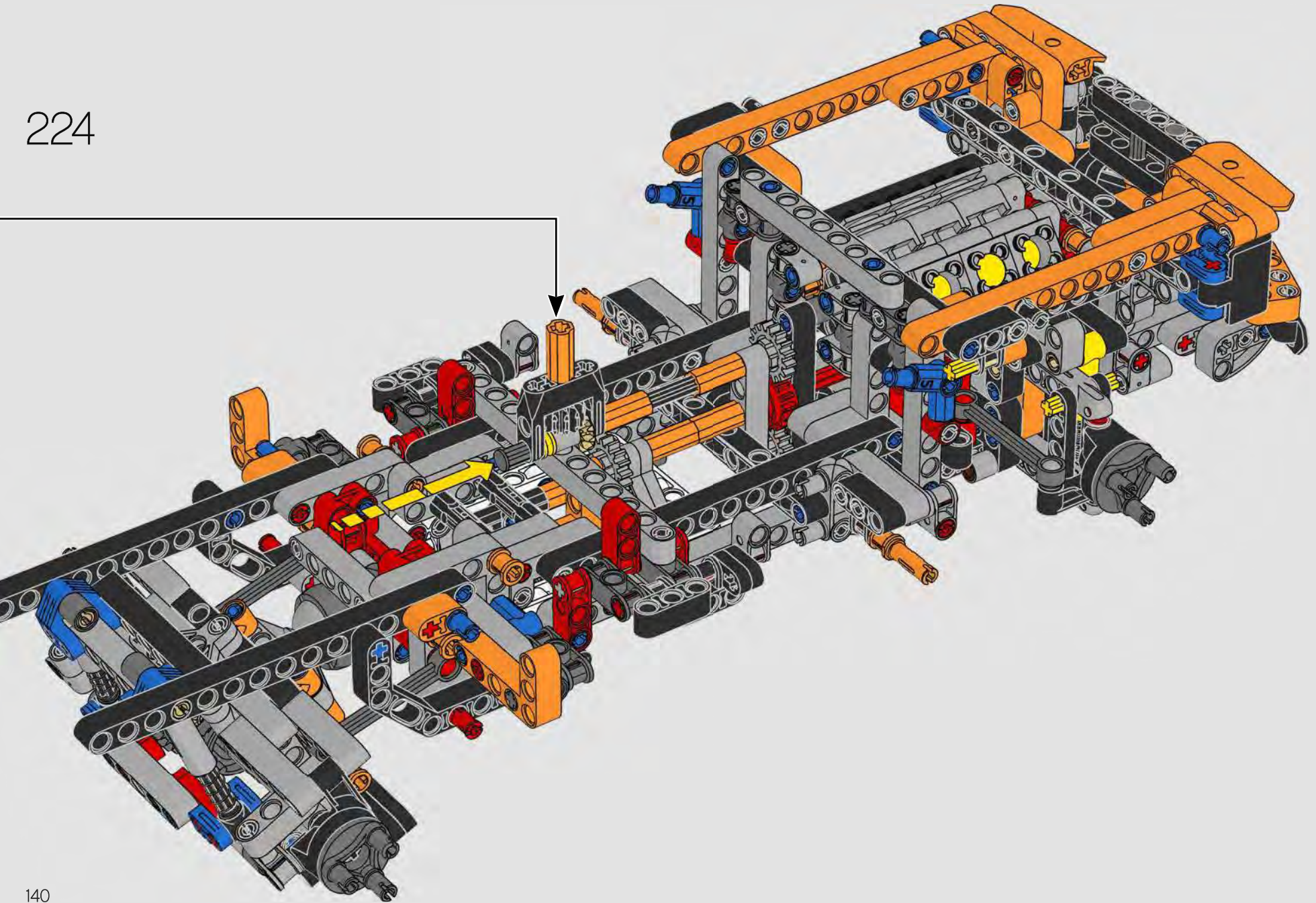

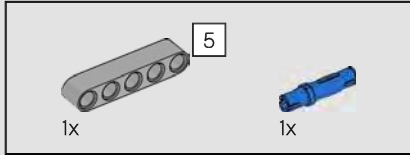
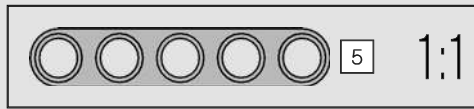

225

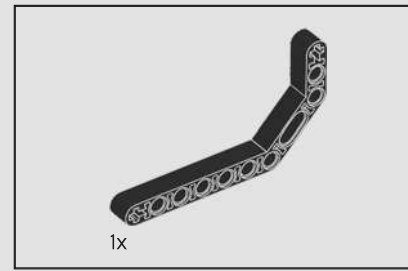
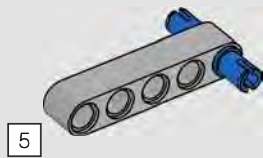

226

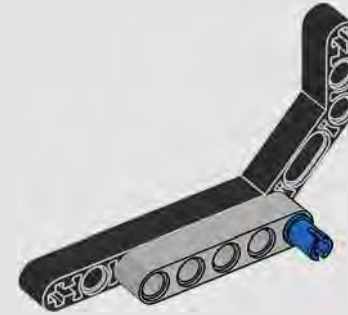

227

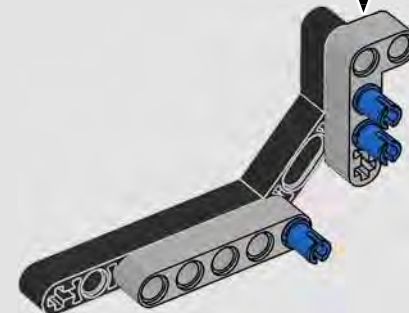
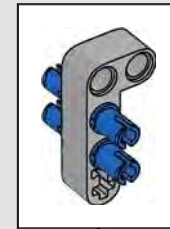

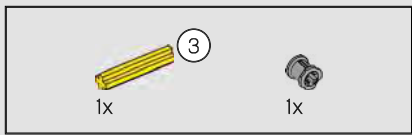

228

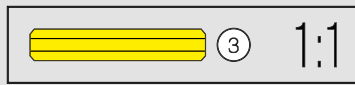
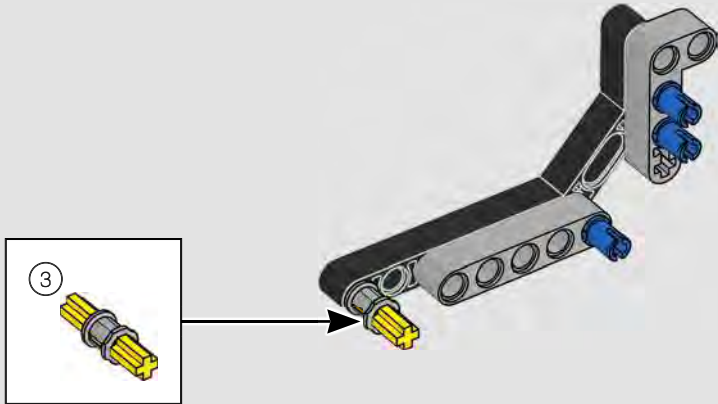

229

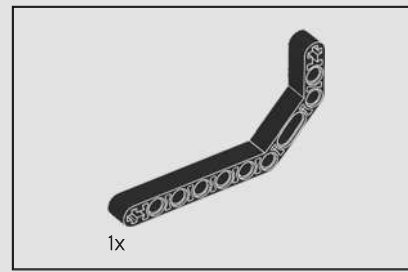
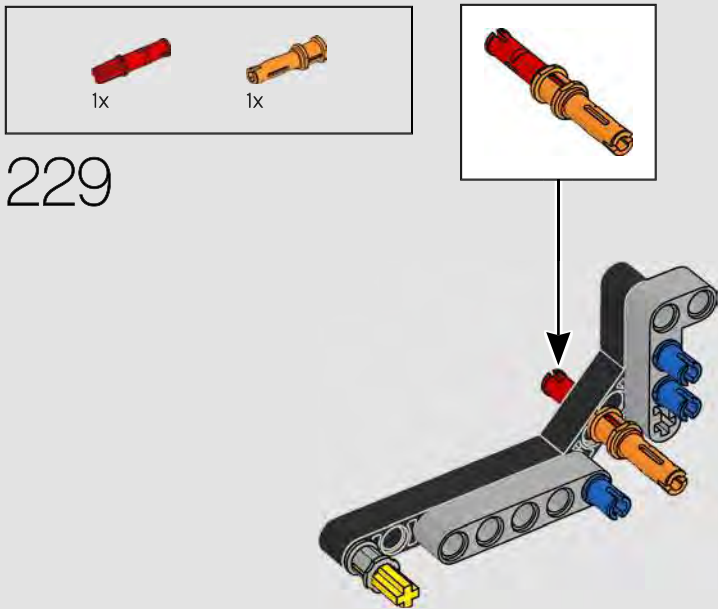

230

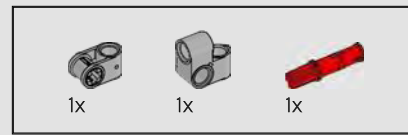
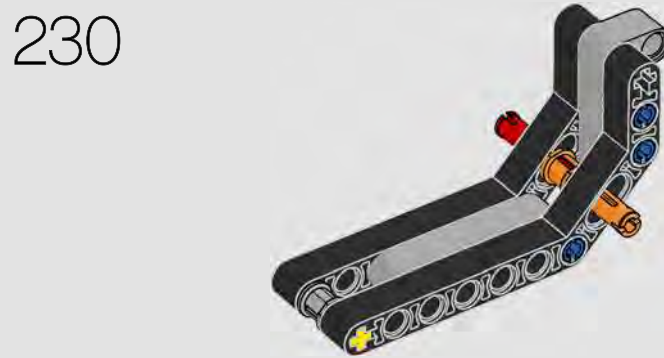

231

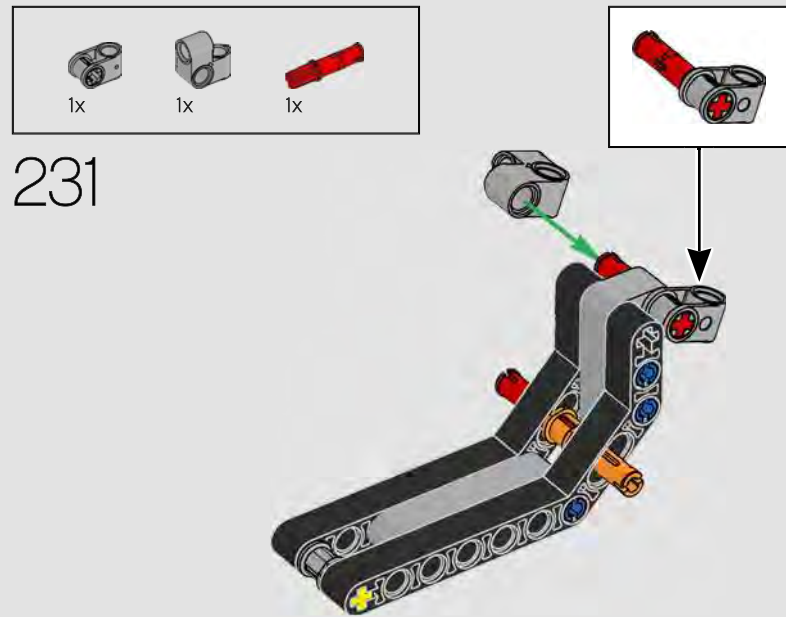

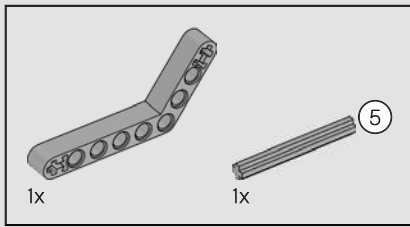

232

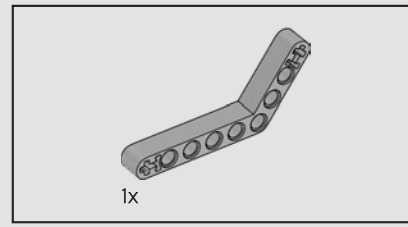
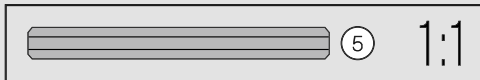
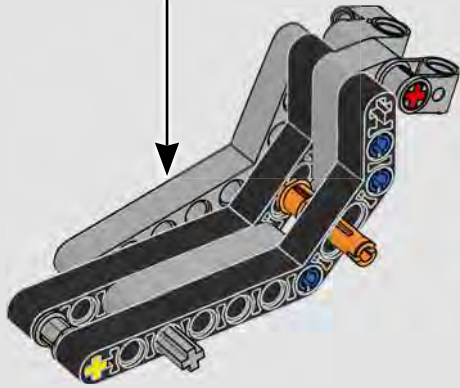
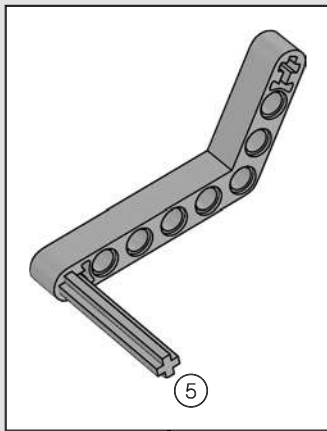

233



234

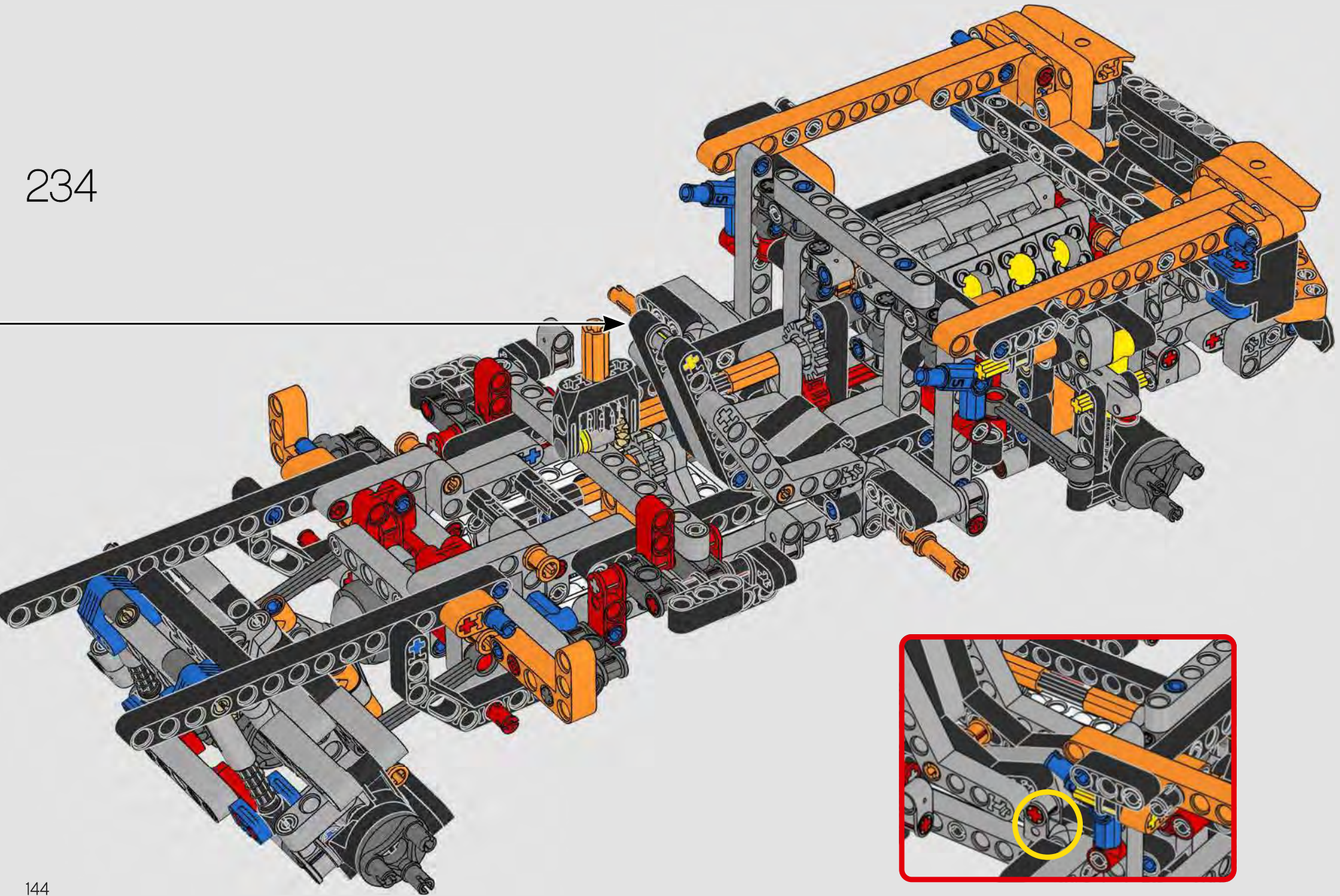



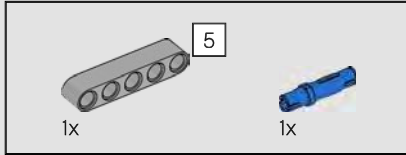
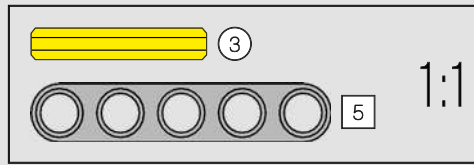

235

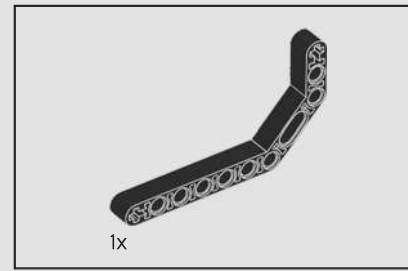
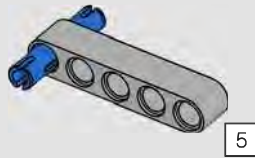

236

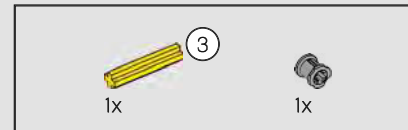
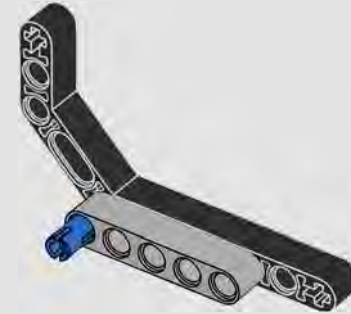

237

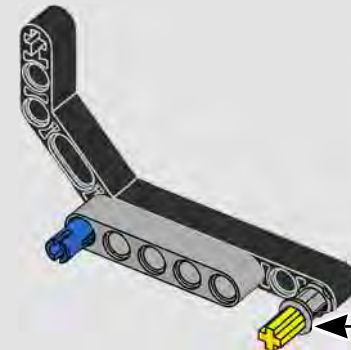



238

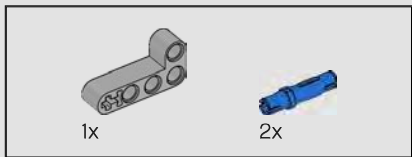
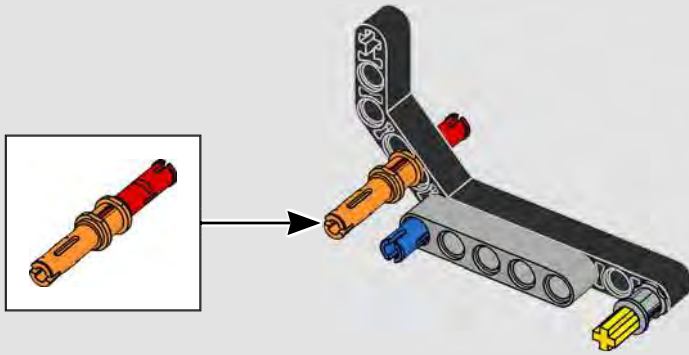

239

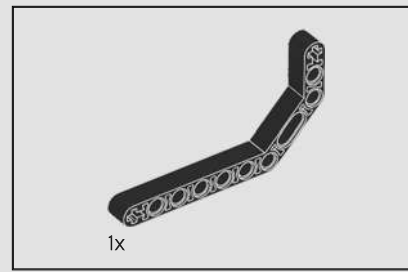
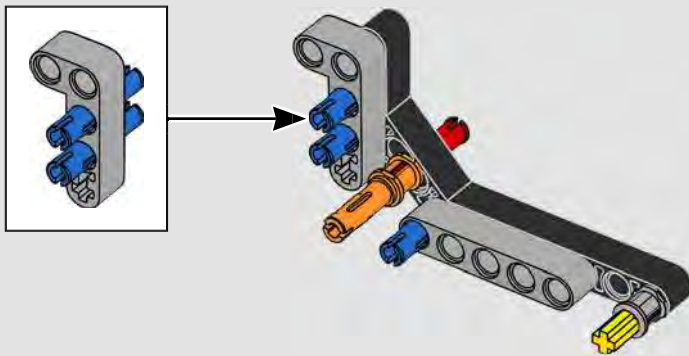

240

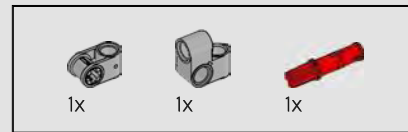
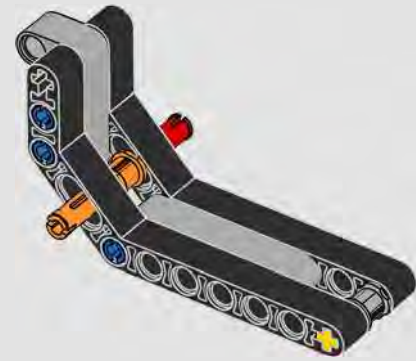

241

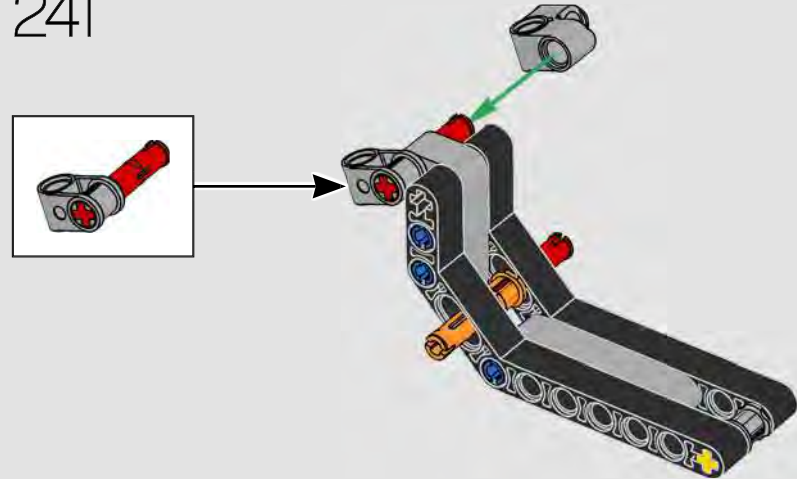

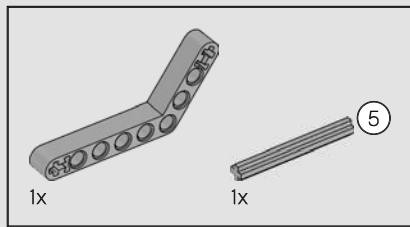

242

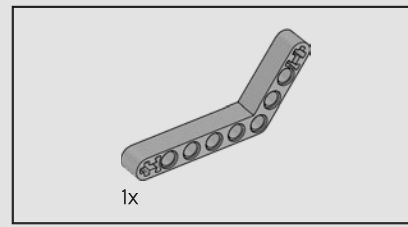
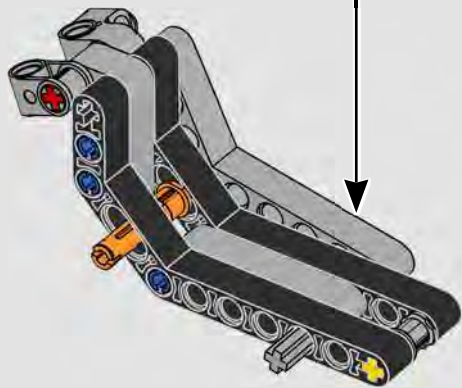
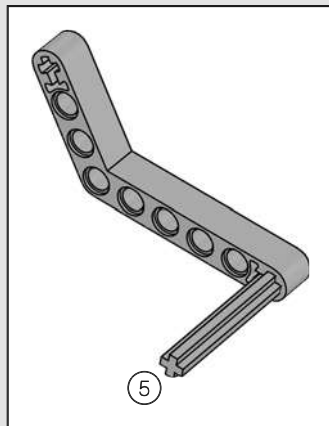
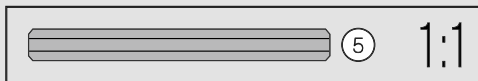

243

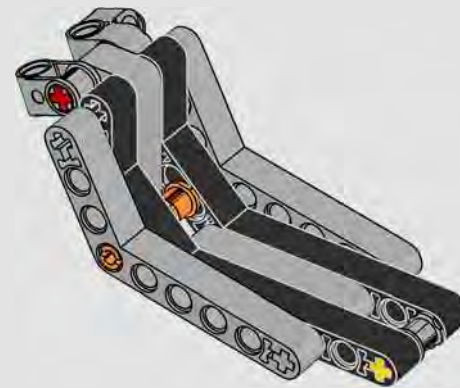

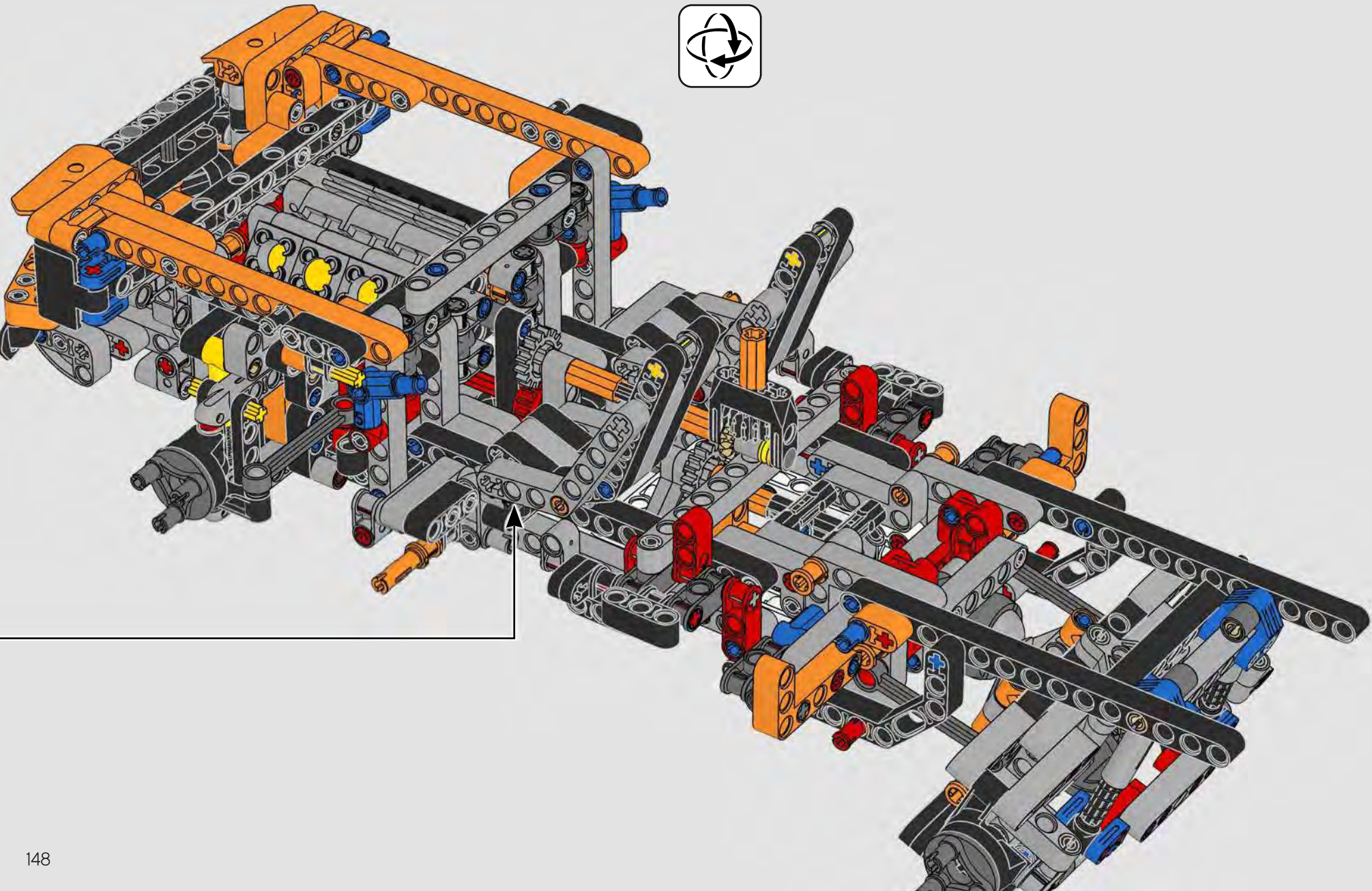
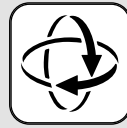

*The fully redesigned 2021 F-150 Raptor boosts its capability with all-new five-link rear suspension to better maintain axle position on rough terrain.*



245

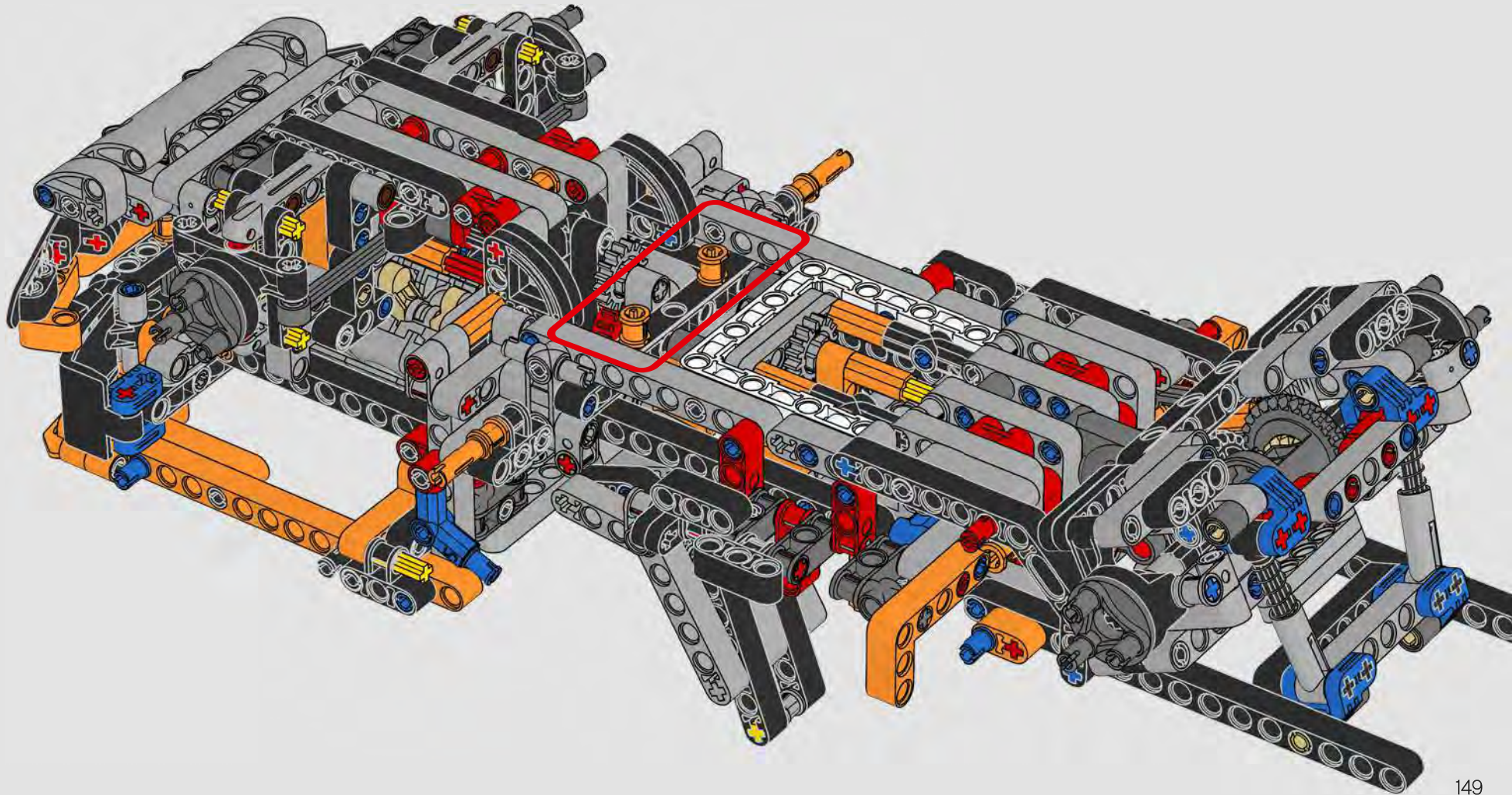

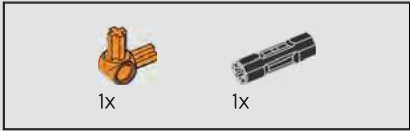
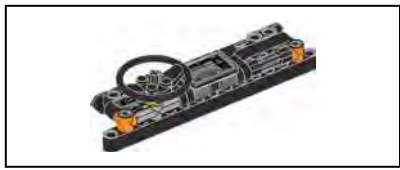

246

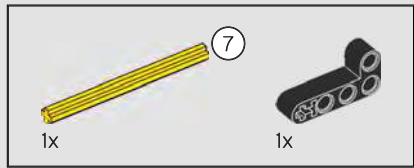
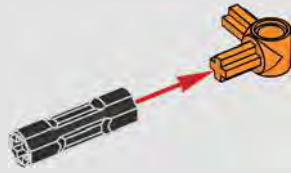

247

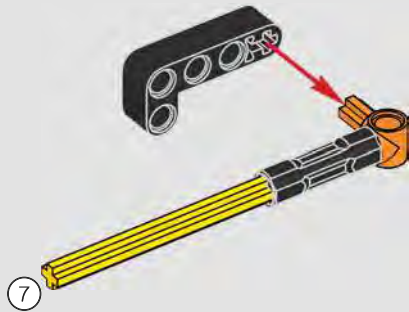

248

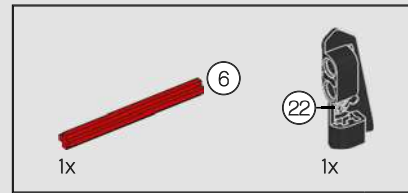
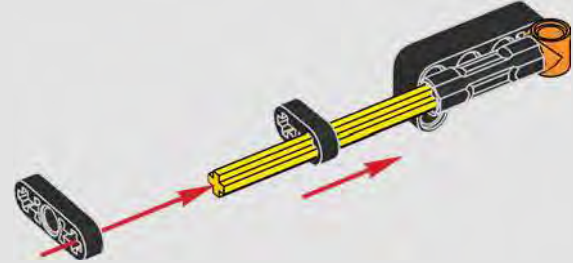

249

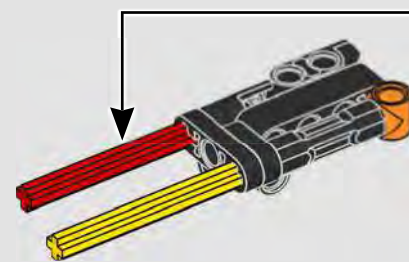
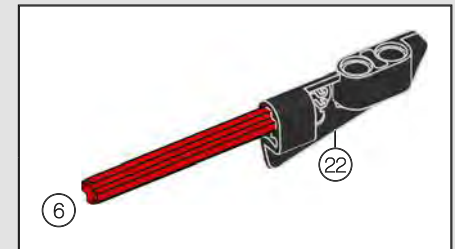

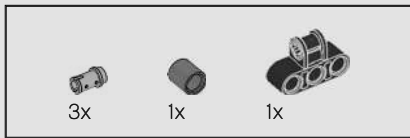

250

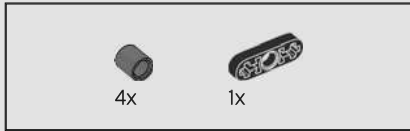
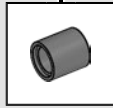
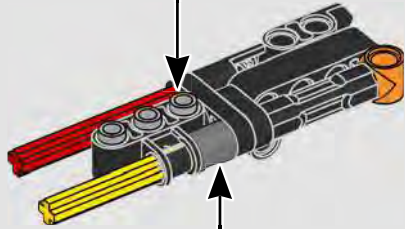

251

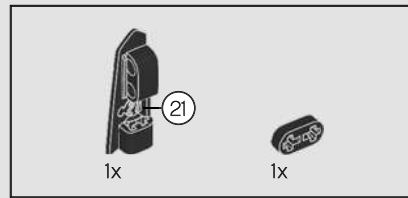
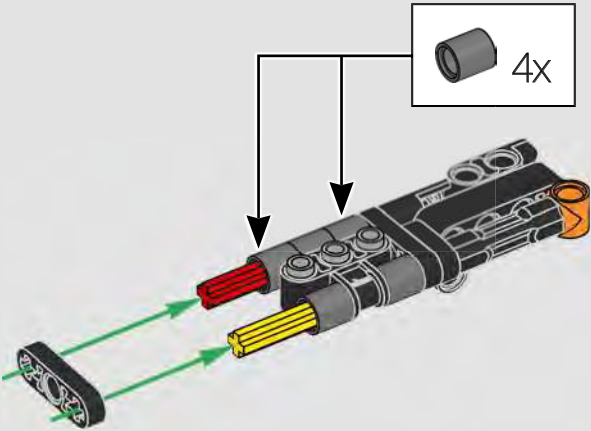

252

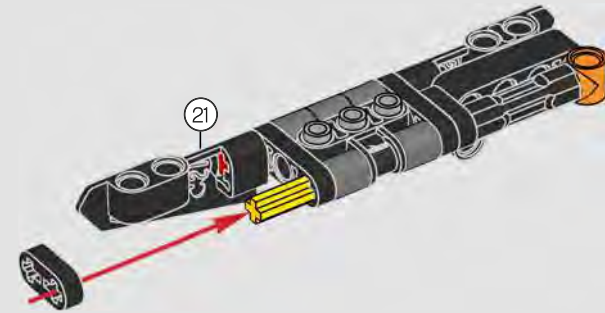

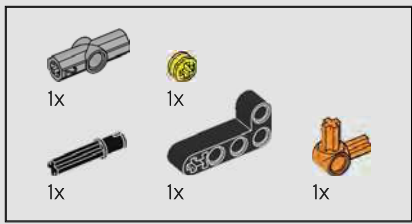

253

1

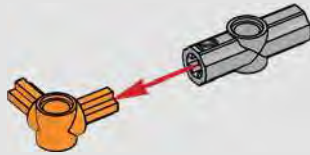

2

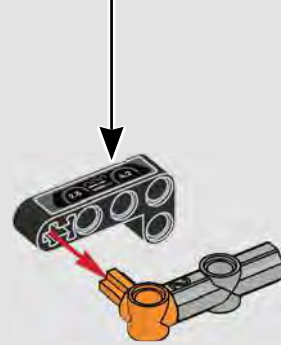
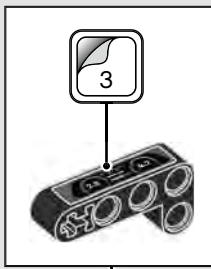

3

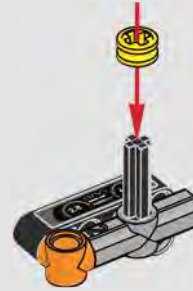

254

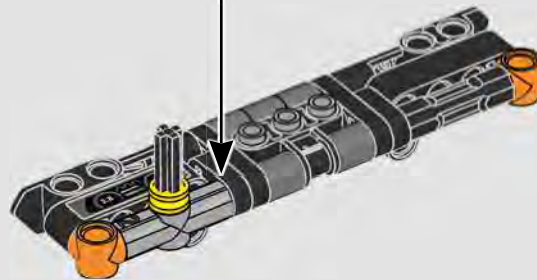



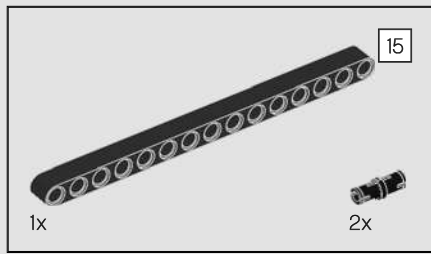

255

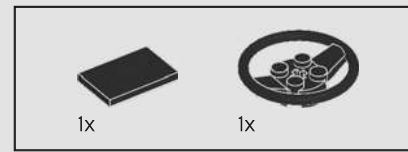
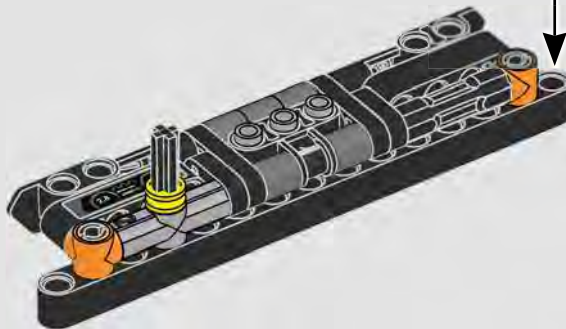

256

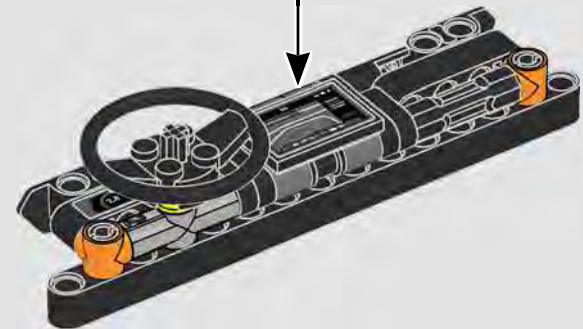
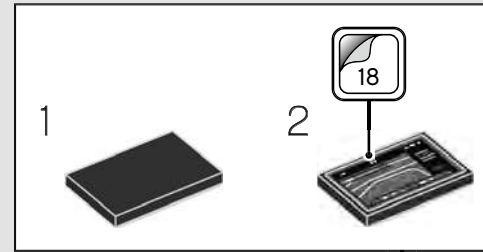

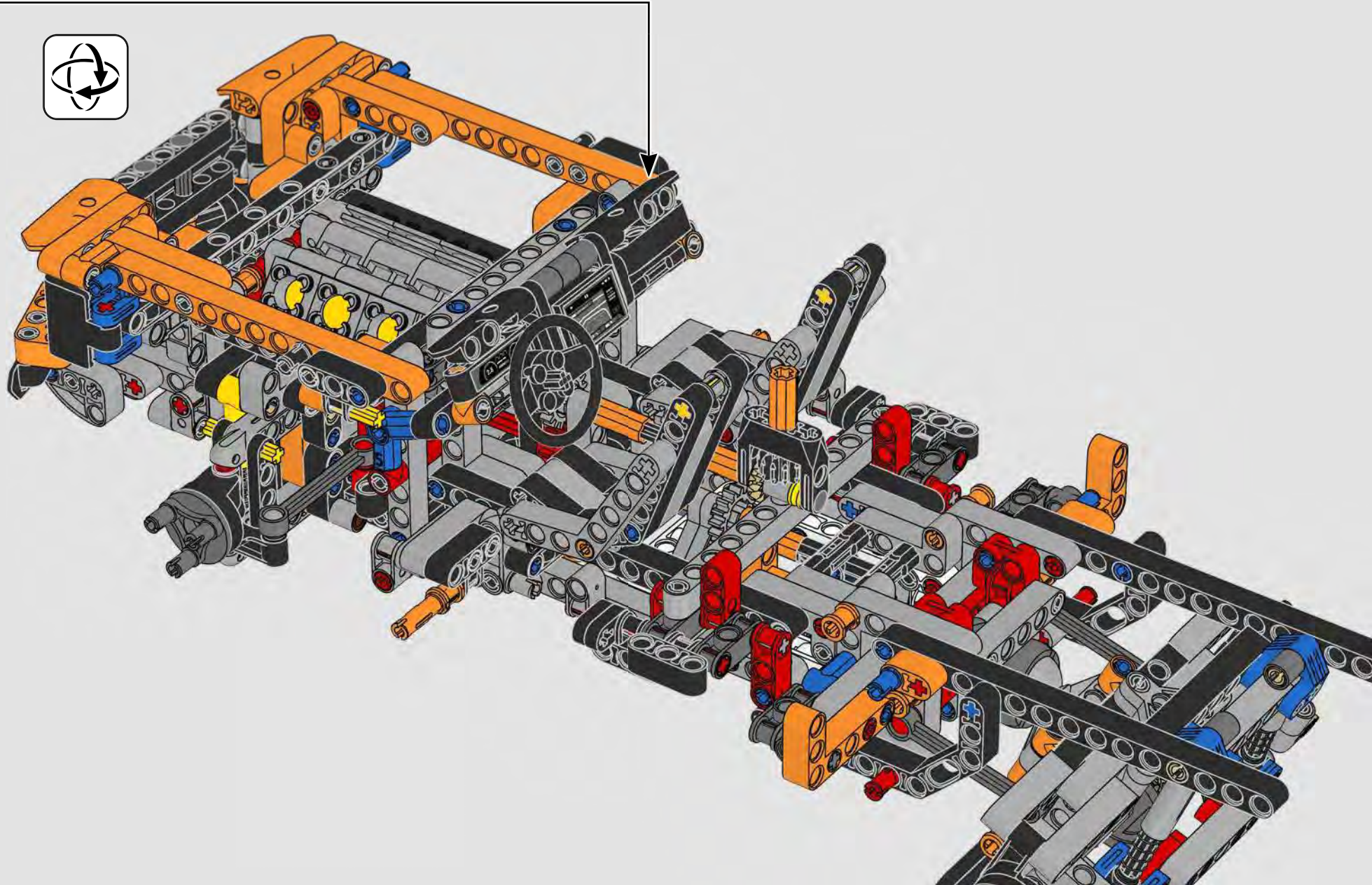

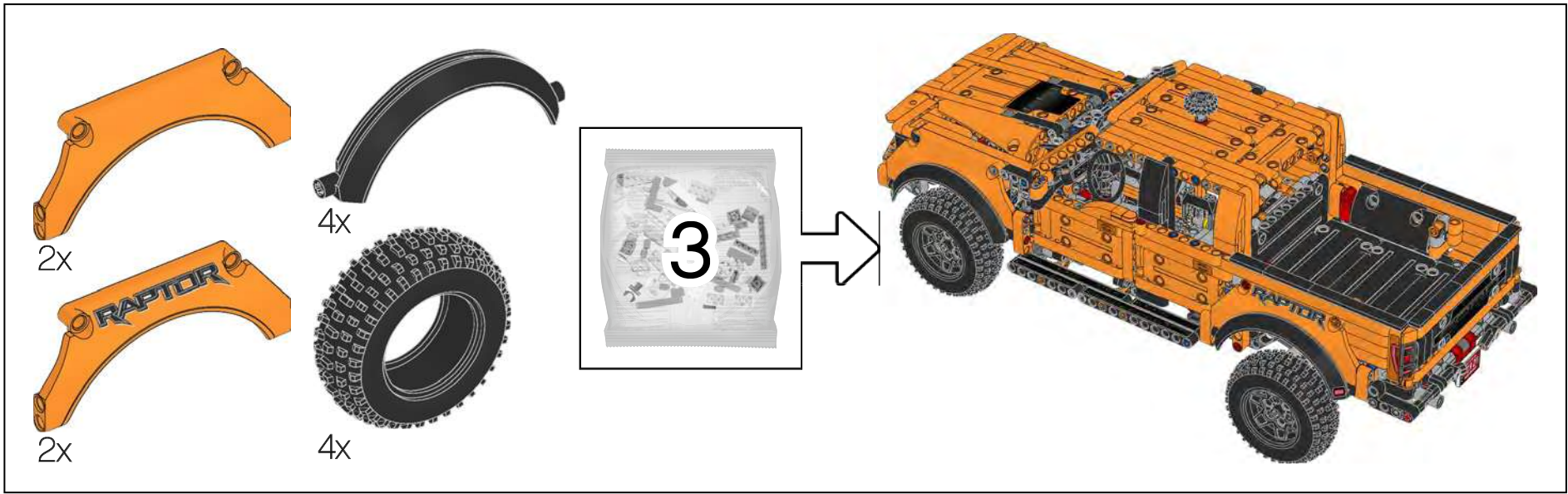



2x

258

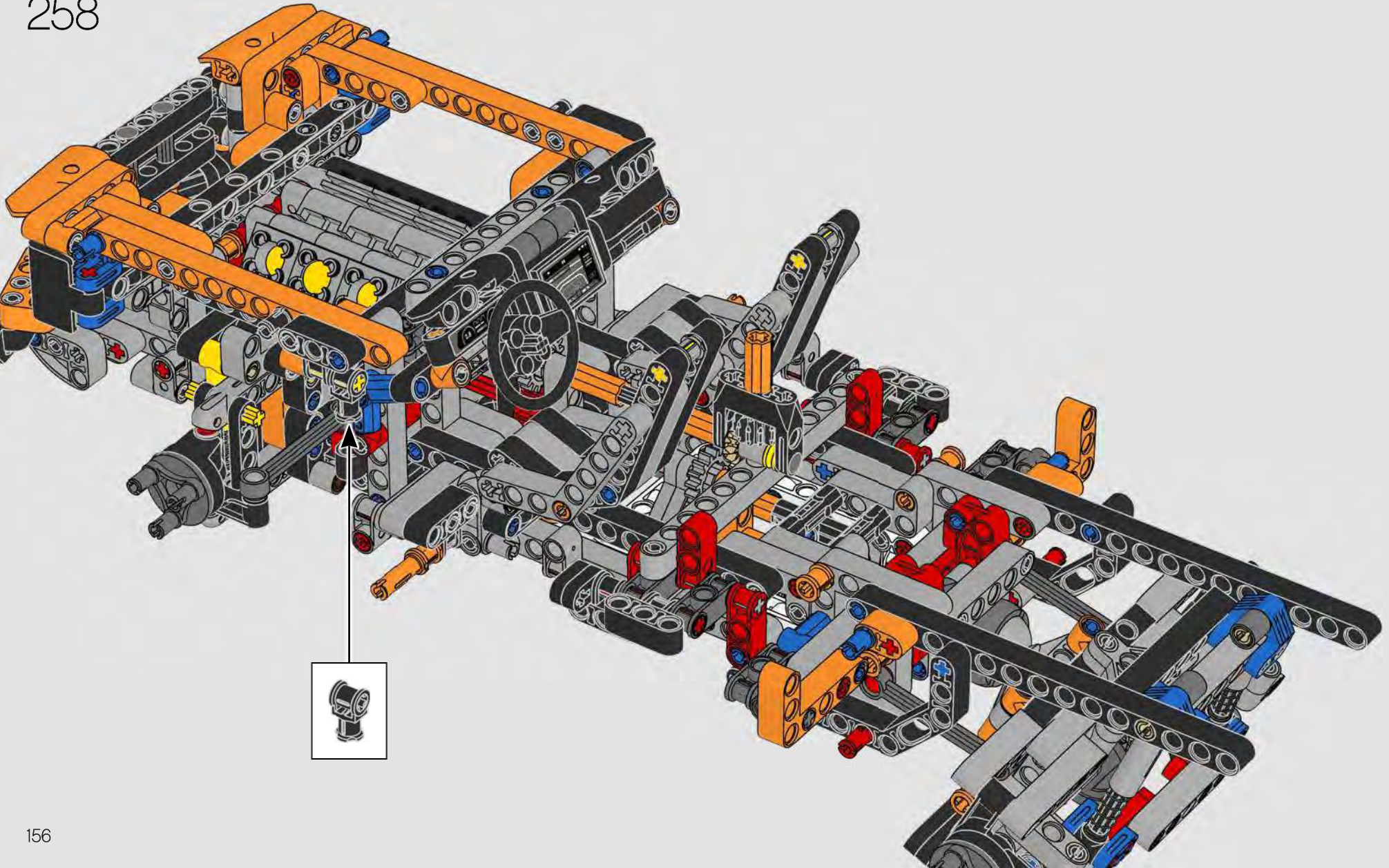

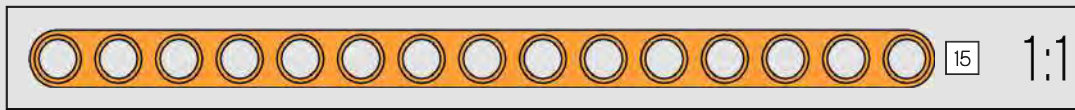
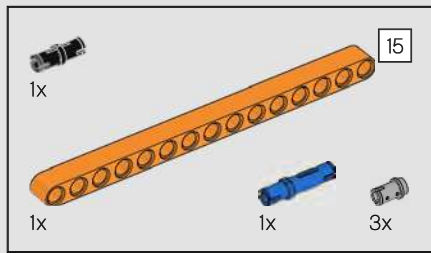

259

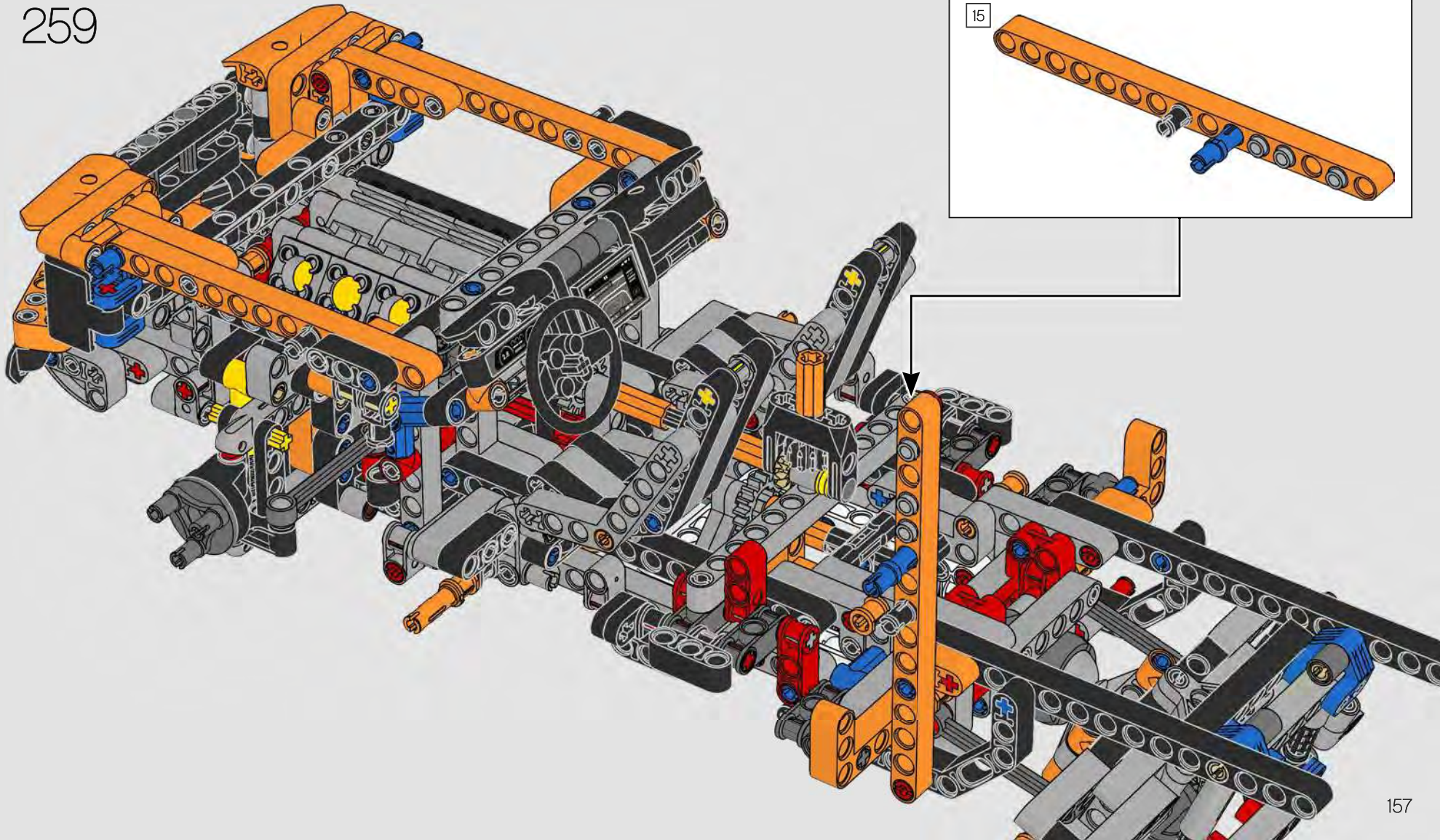
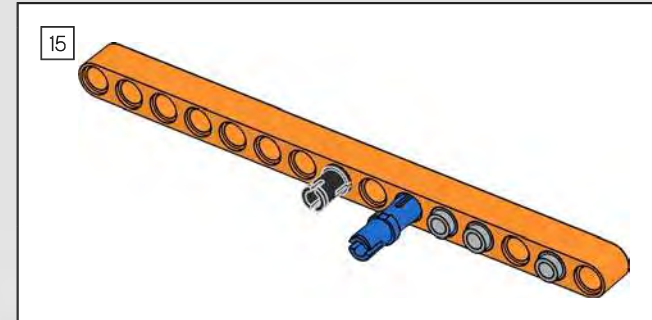

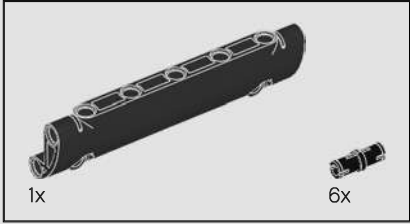
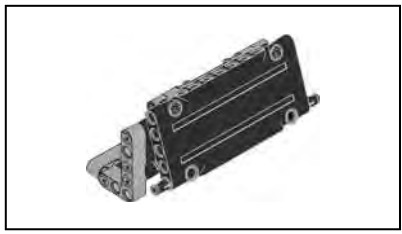

260

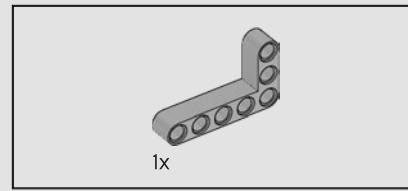
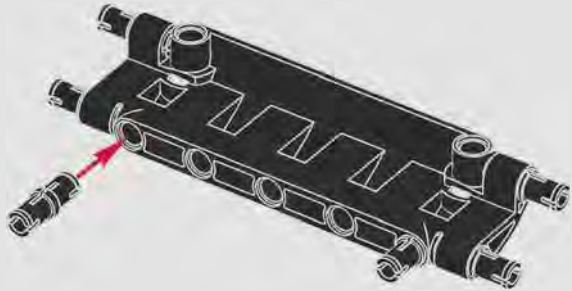

261

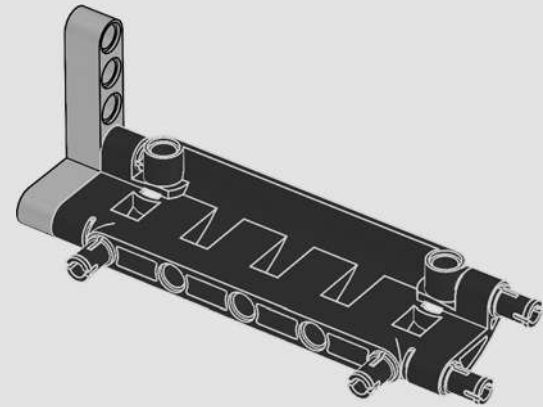

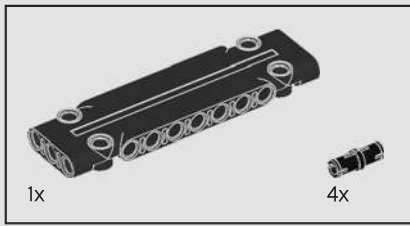

262

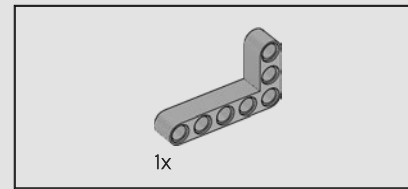
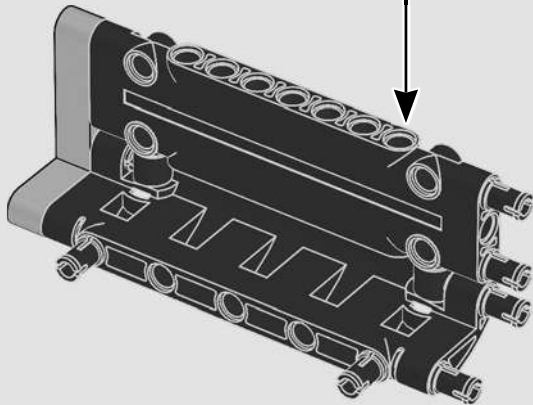

263

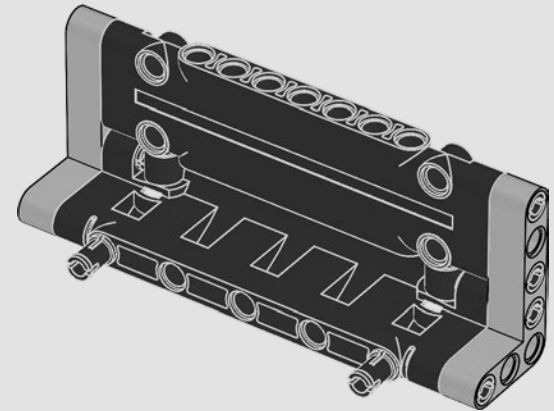

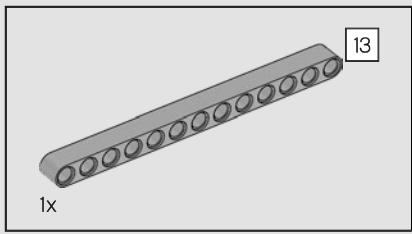

264

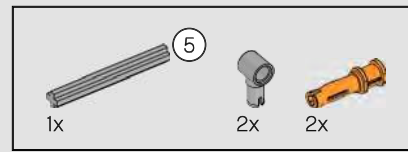
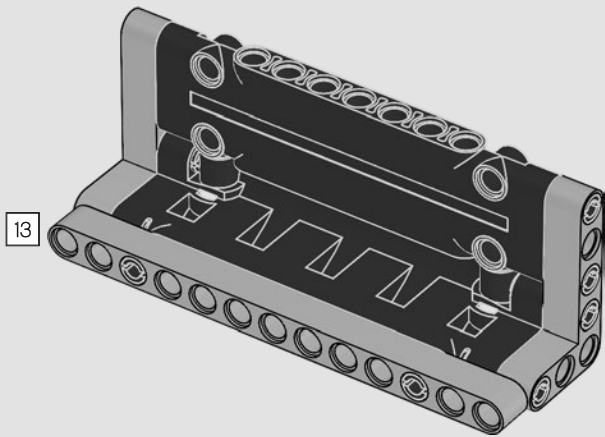

265

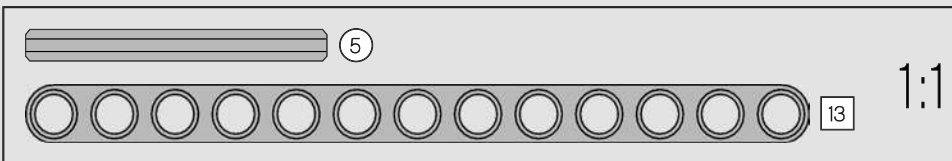
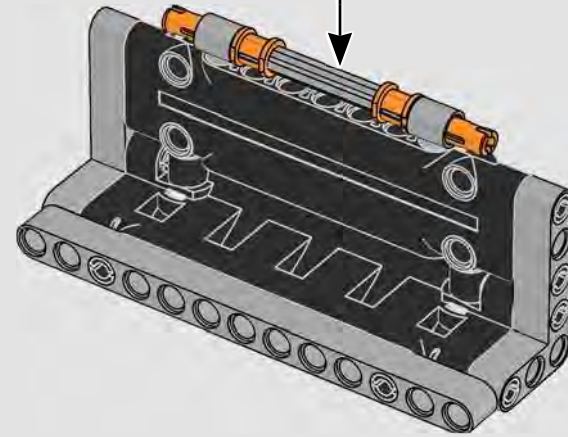
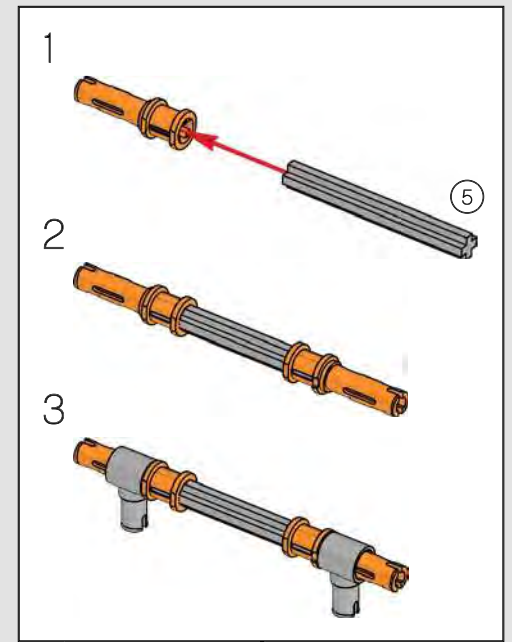





266

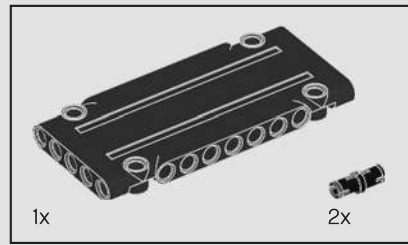
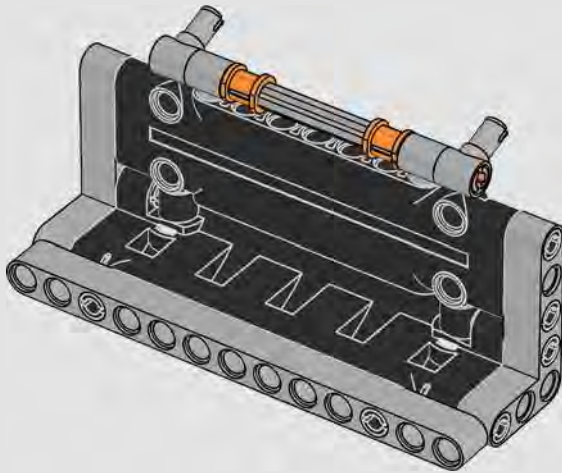

267

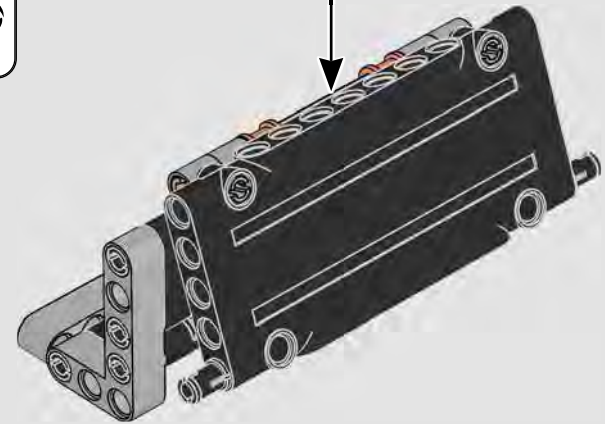
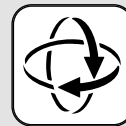
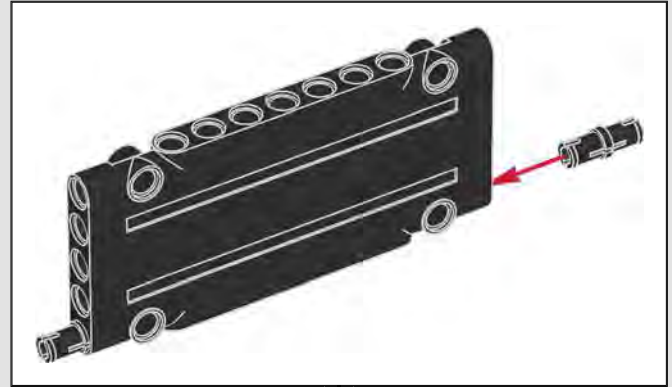

268

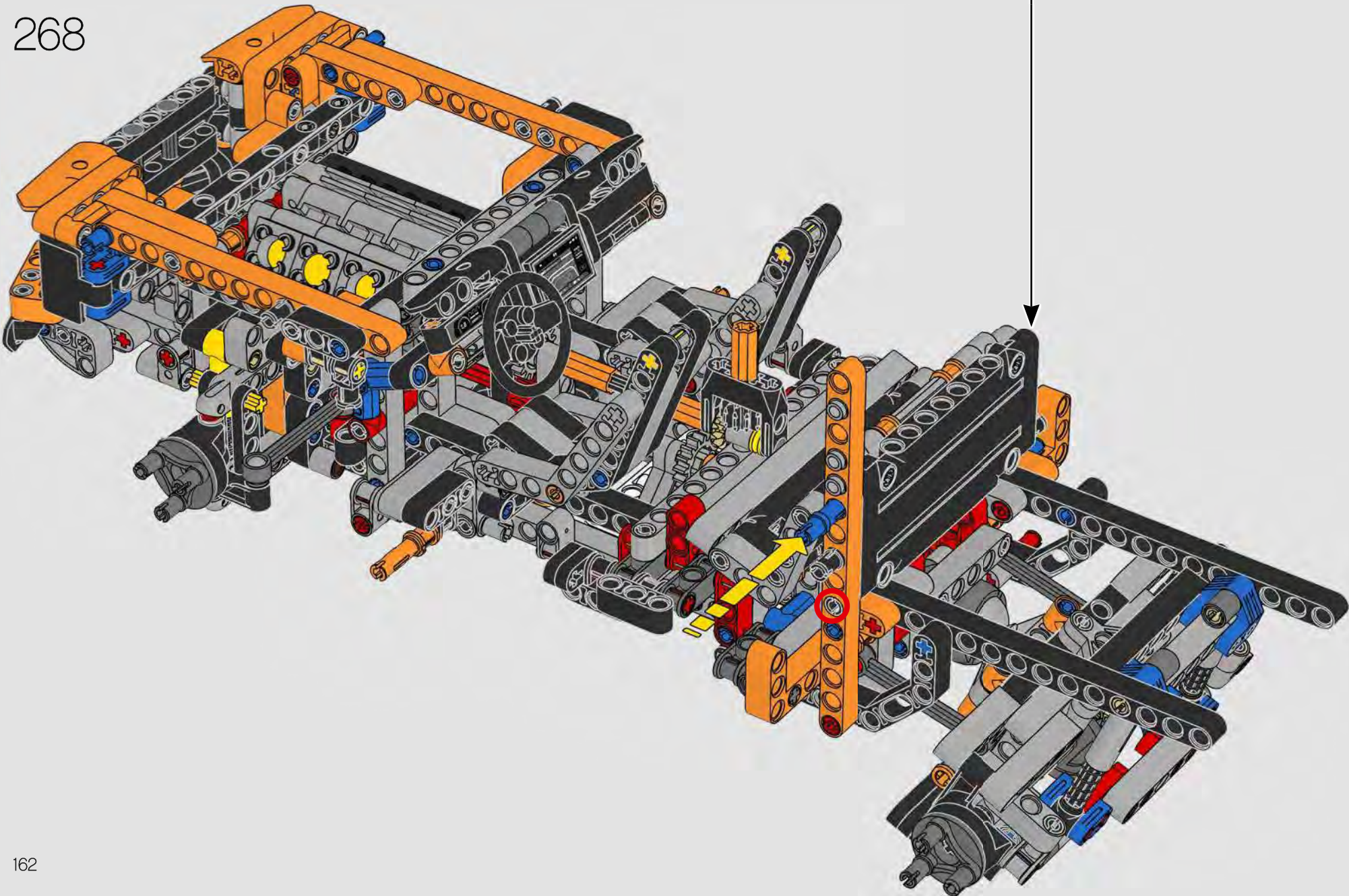

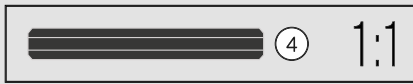
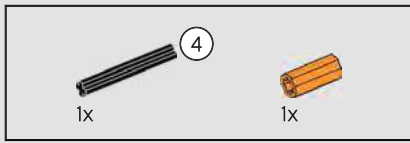

269

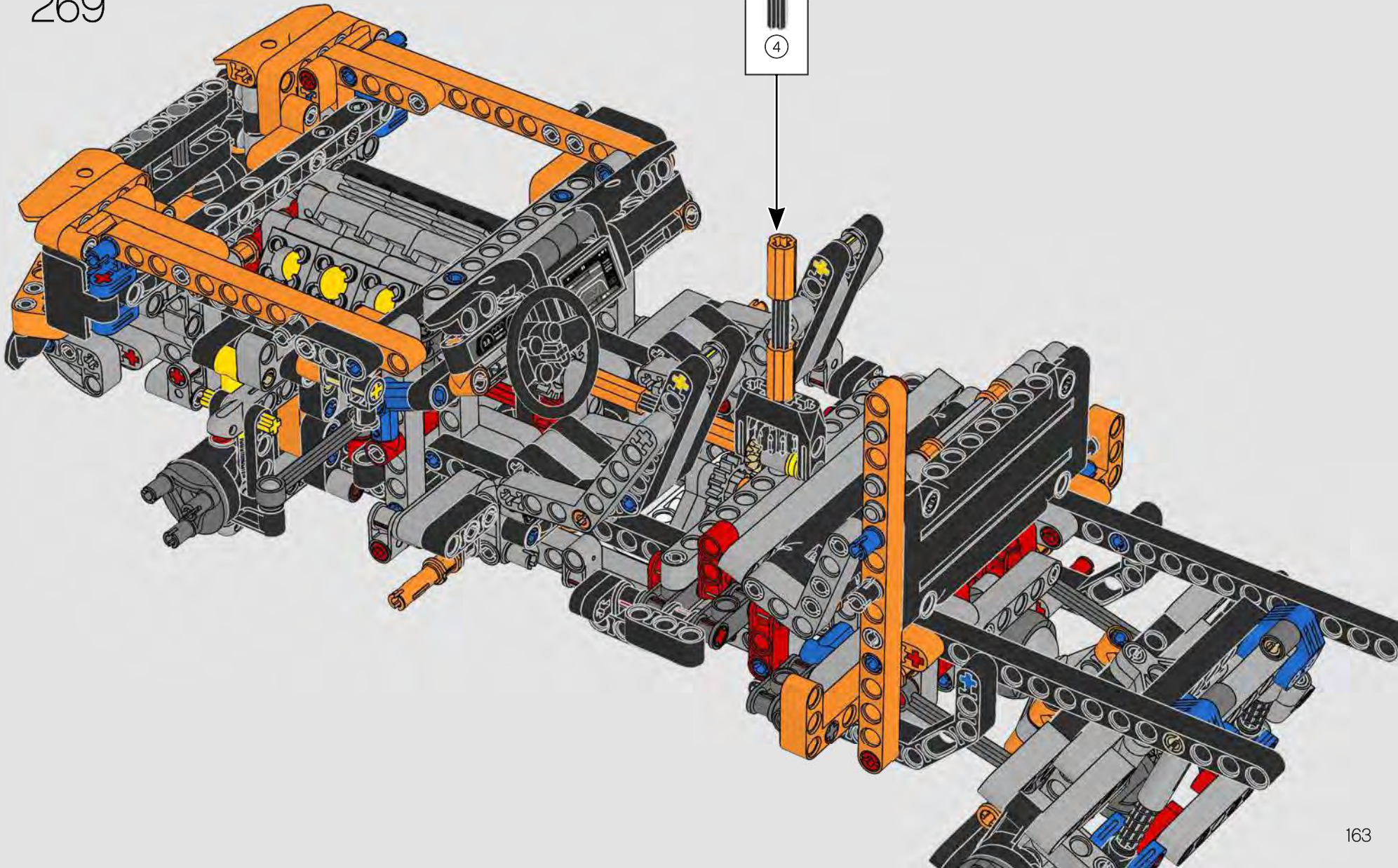
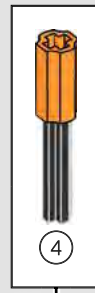

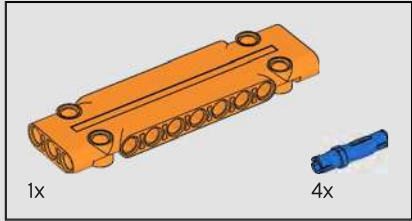
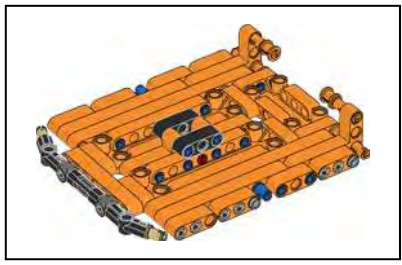

270

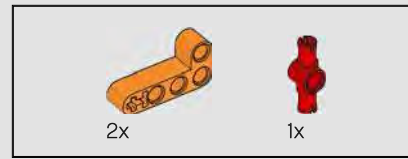
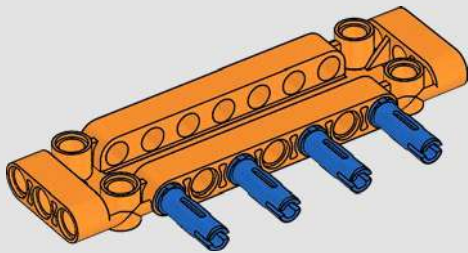

271

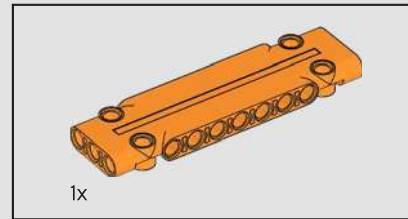
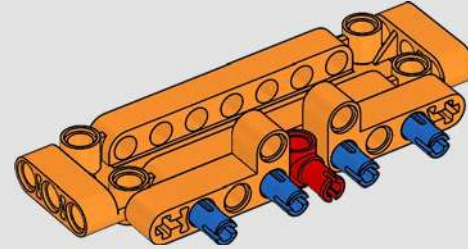

272

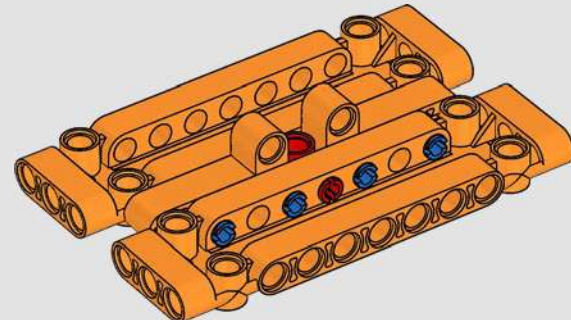



273

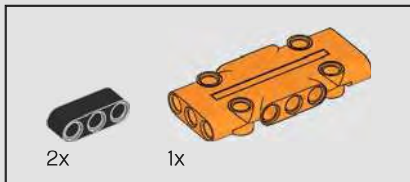
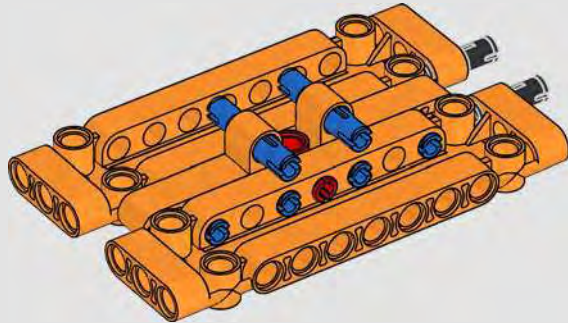

274

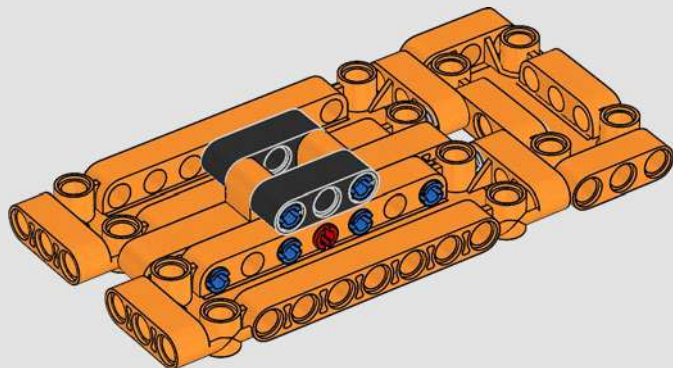

275

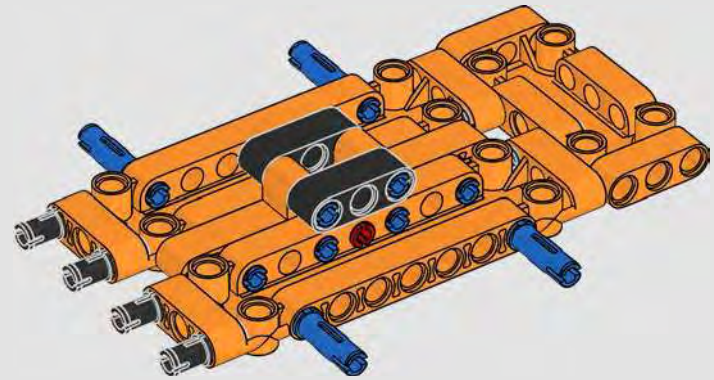

276

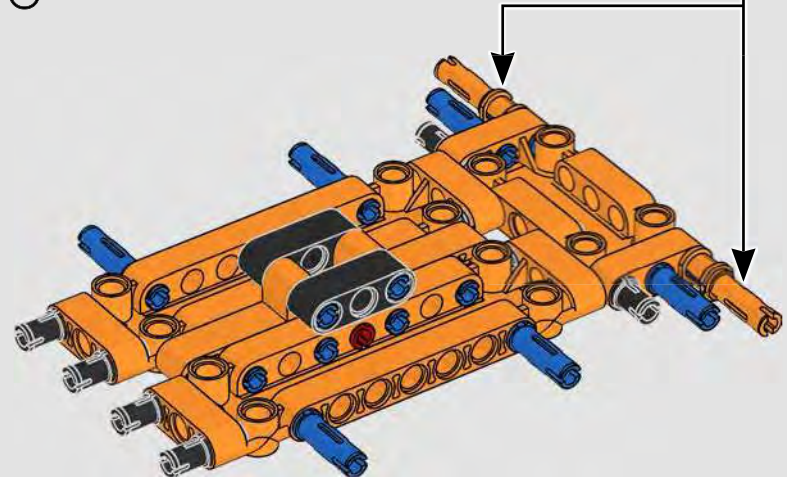
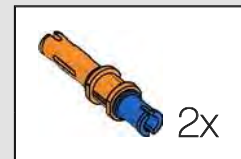

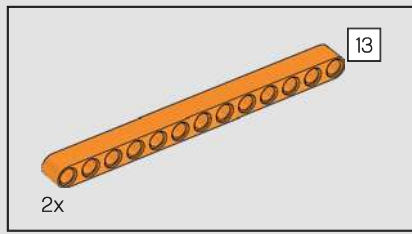

277

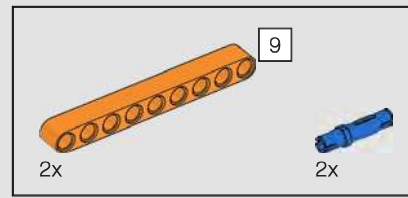
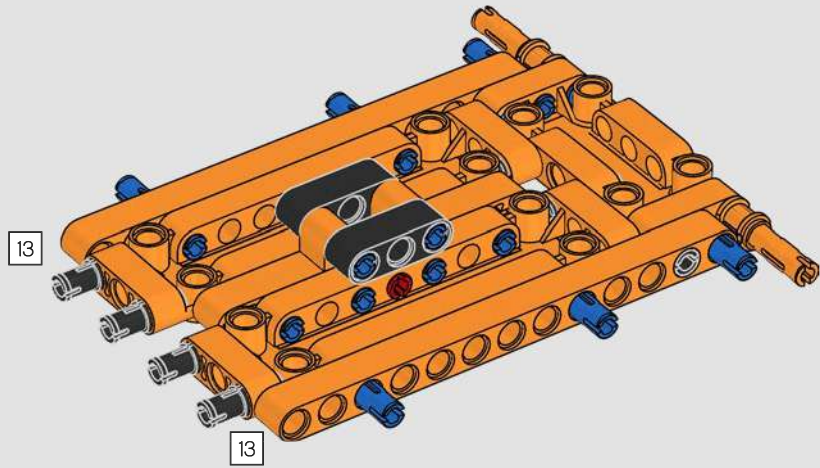

278

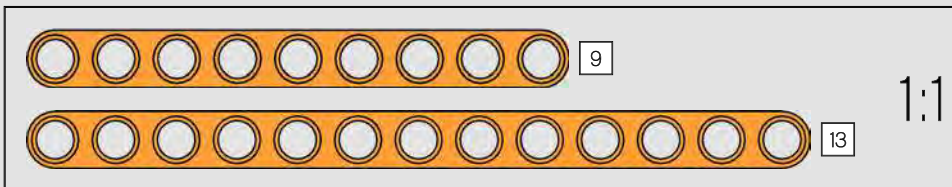
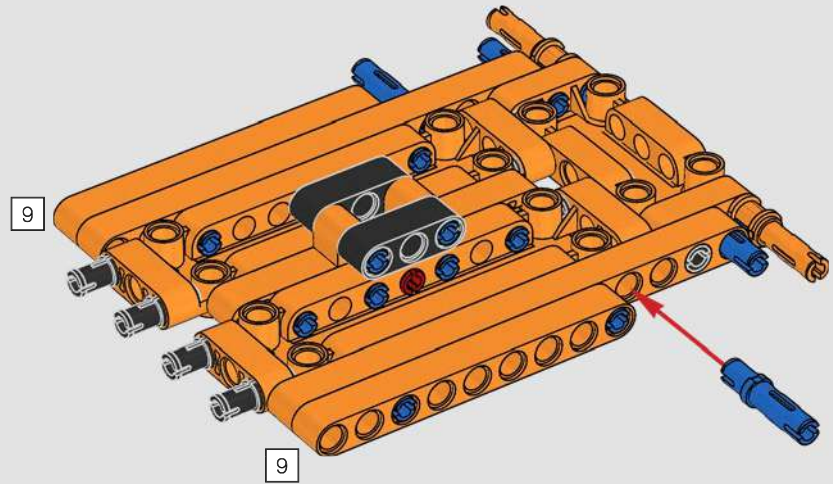



279

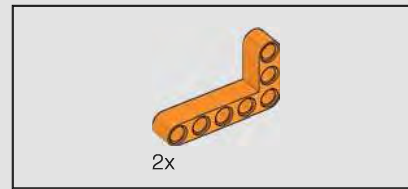
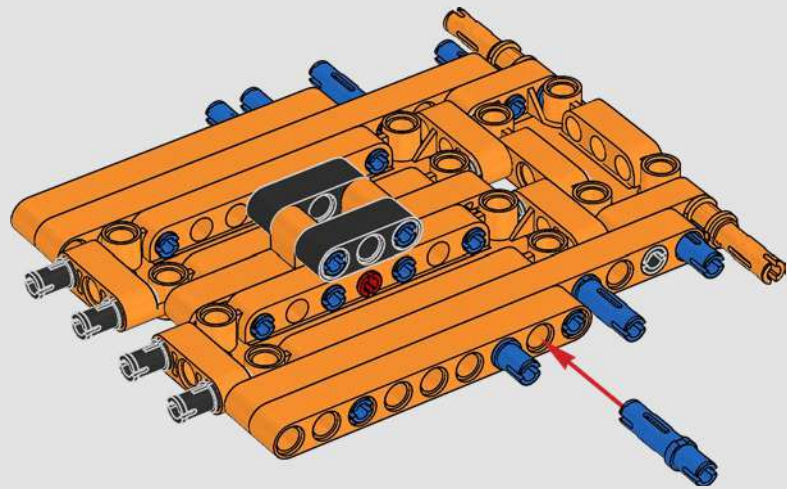

280

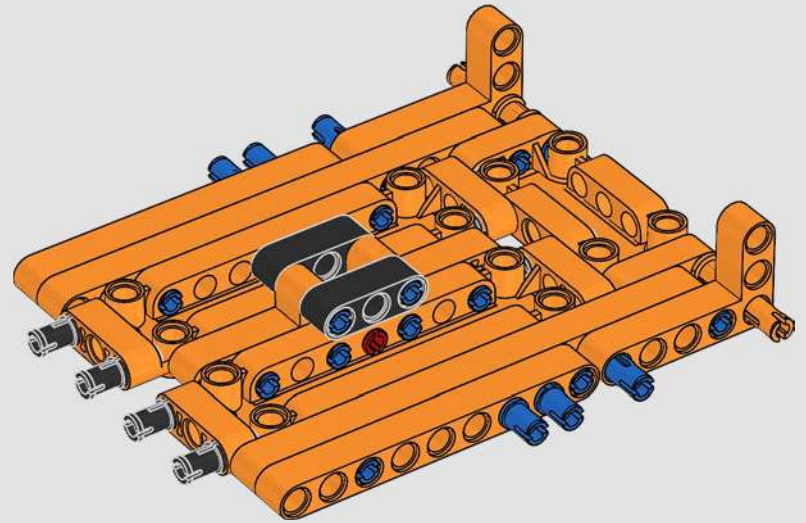



12x

281

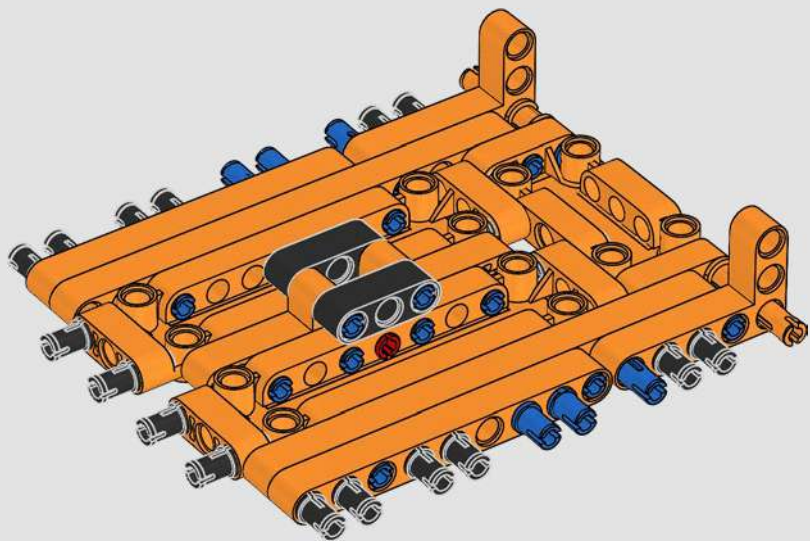

8x

282

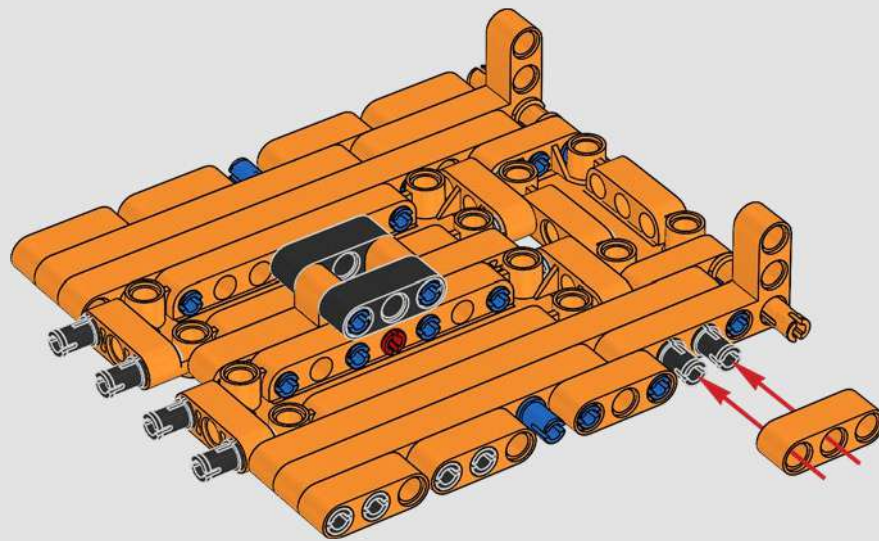



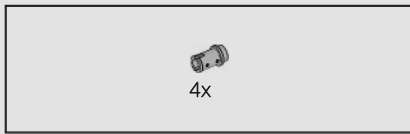

283

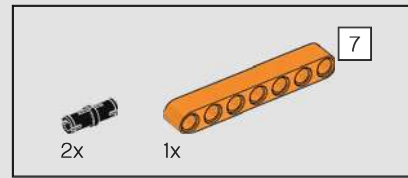
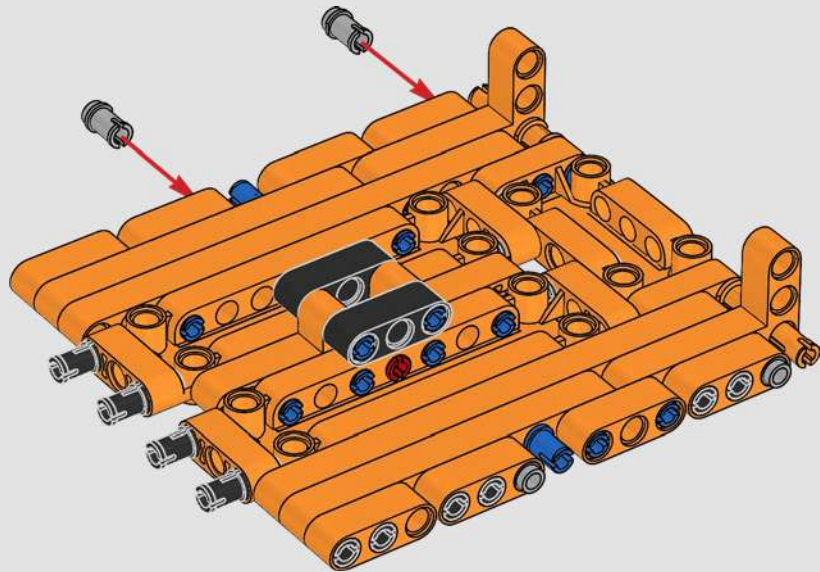

284

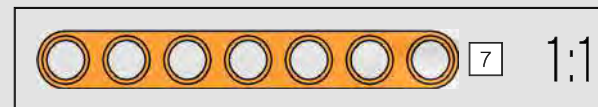
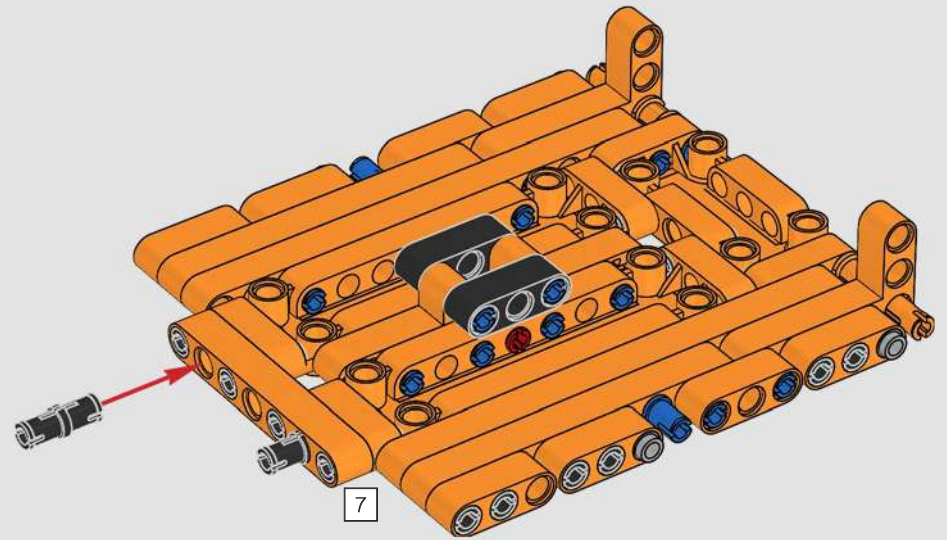

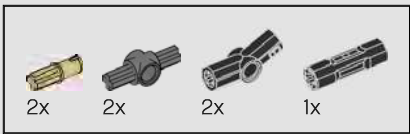

285

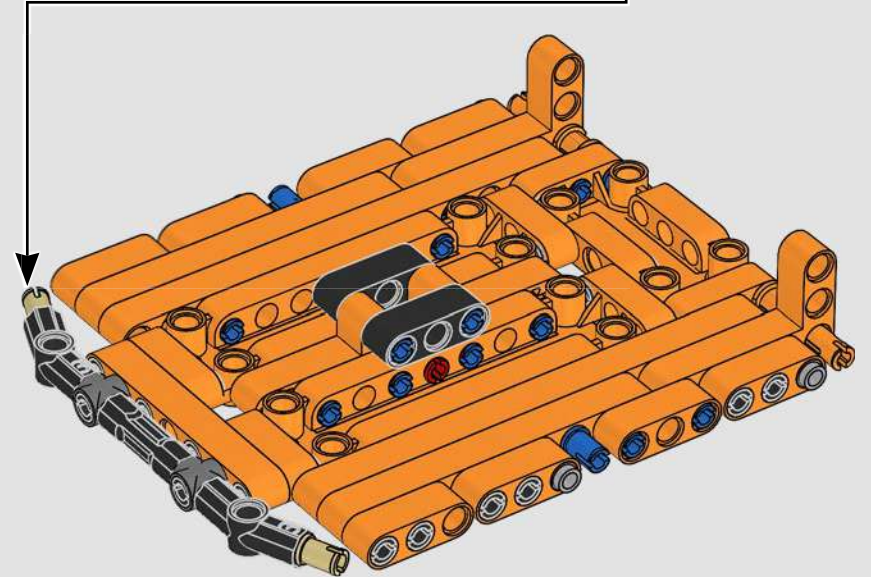
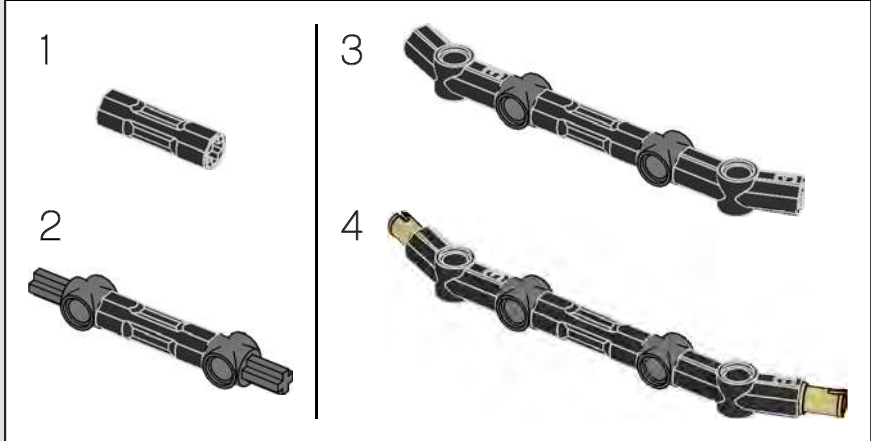

286

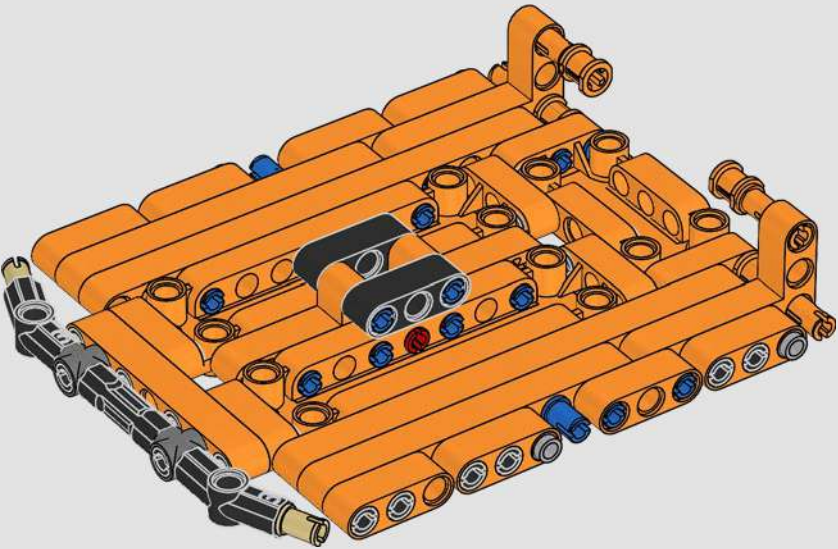

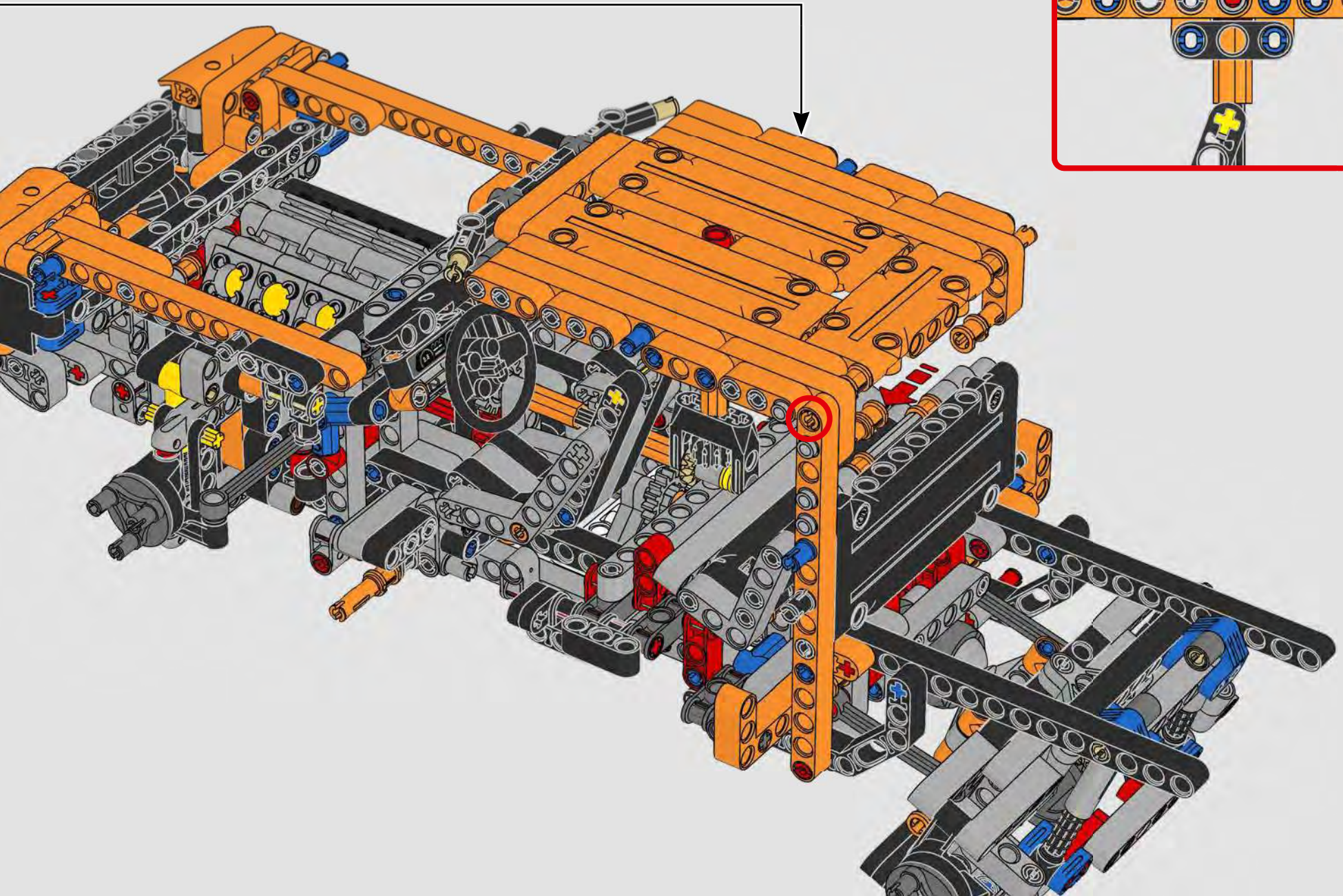

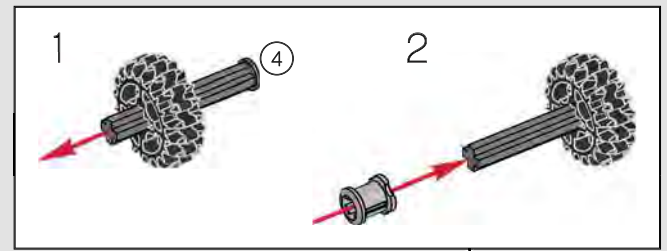
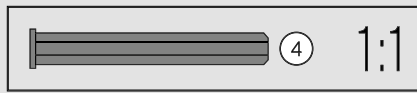
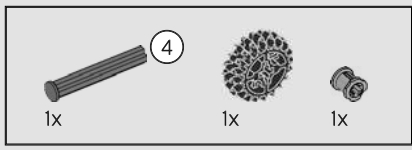

288

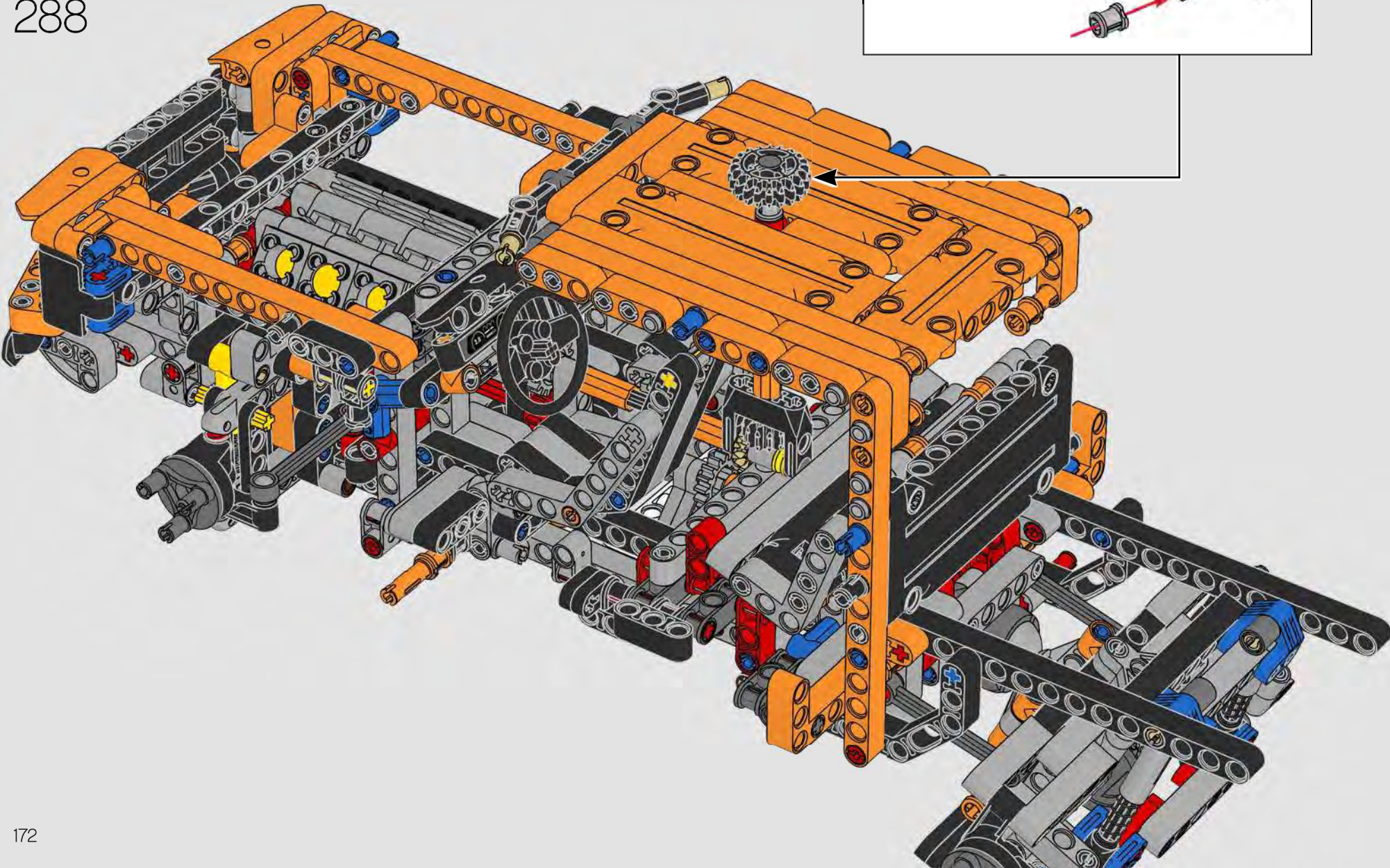

*The F-150 Raptor also includes a high-tech cruise control system for low-traction driving.*

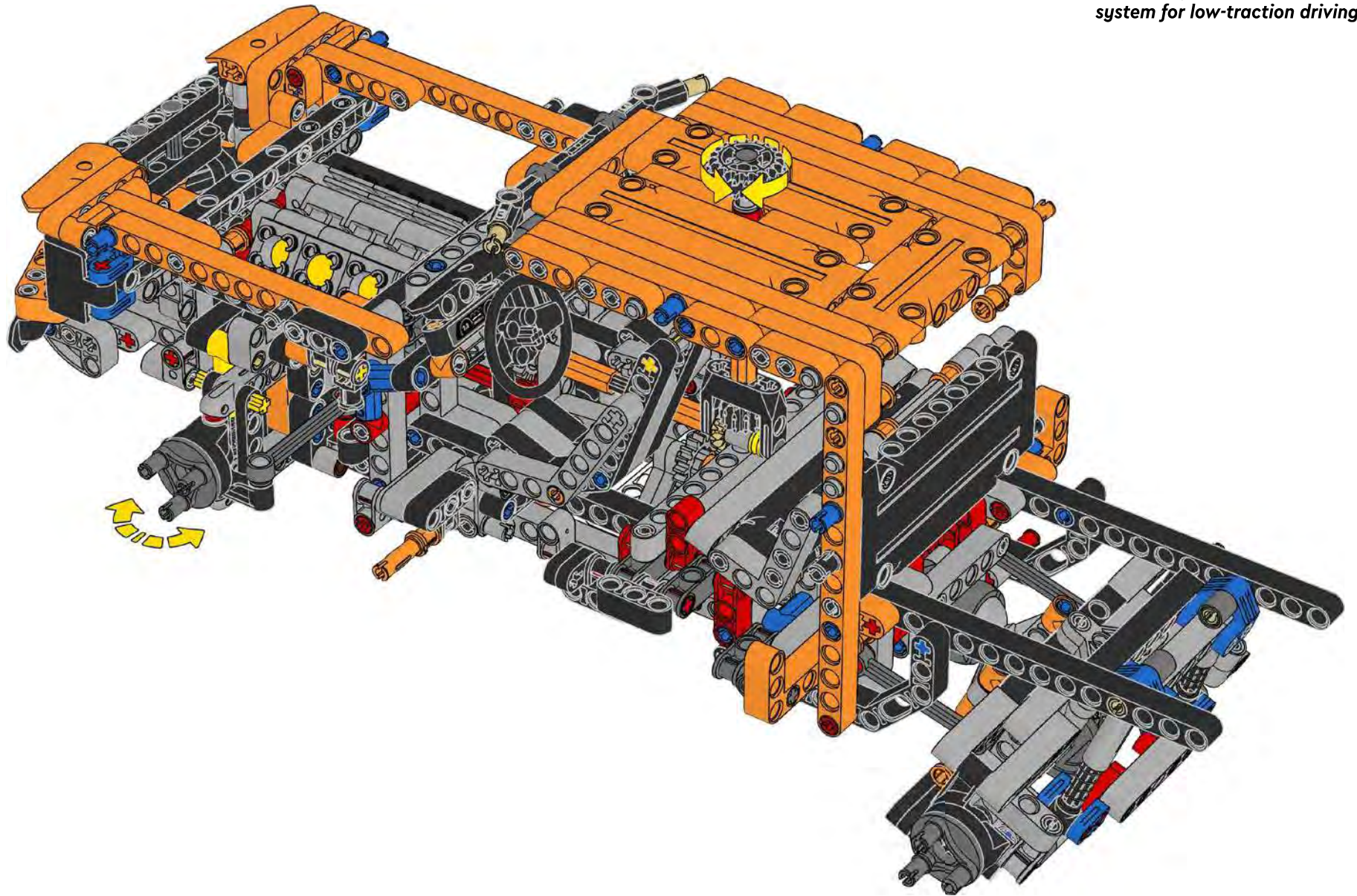

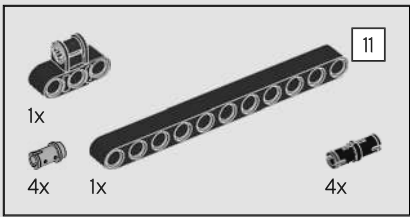

289

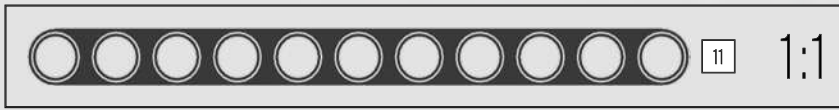
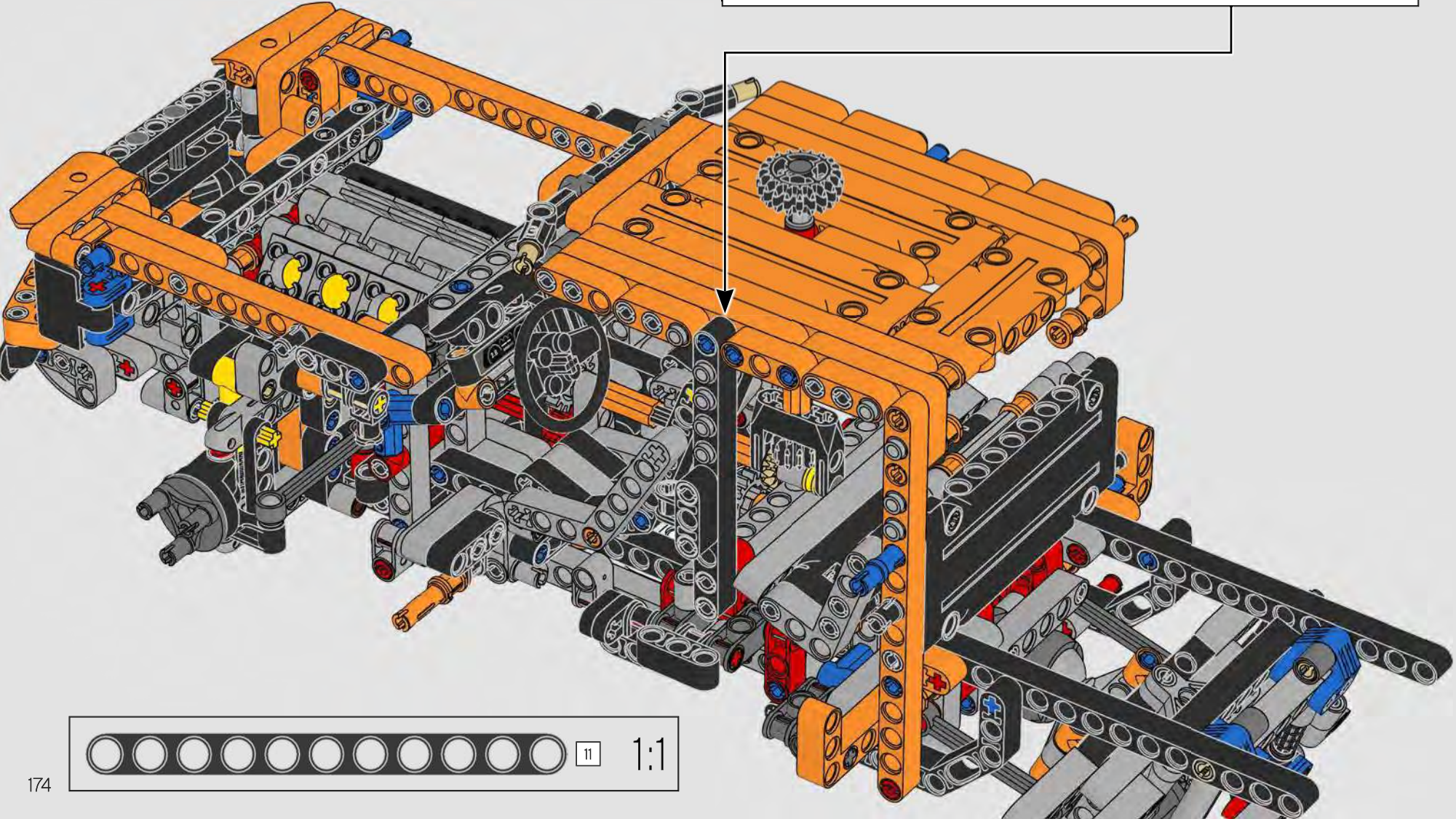
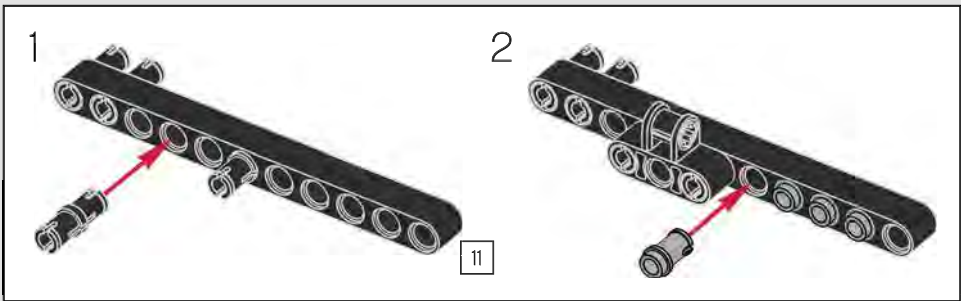

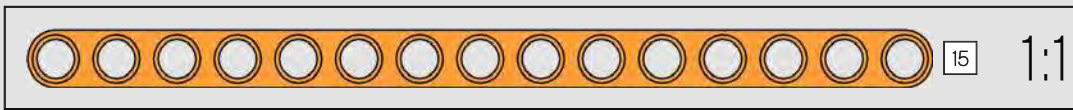
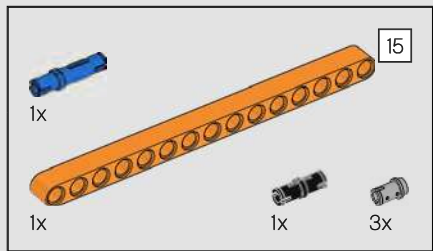

290

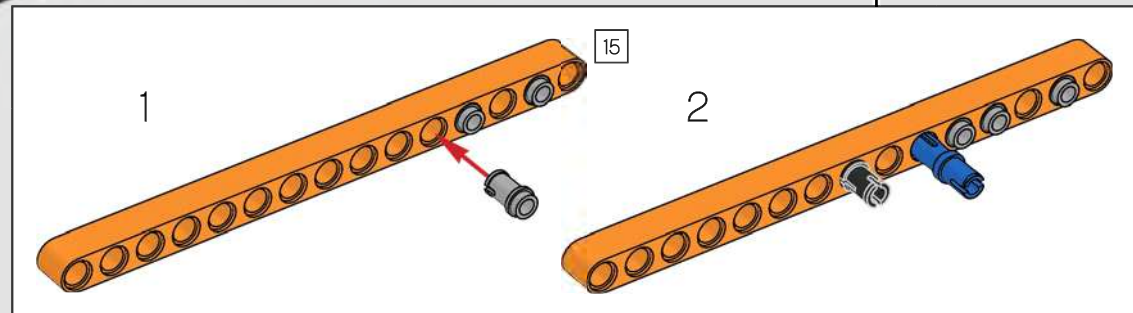
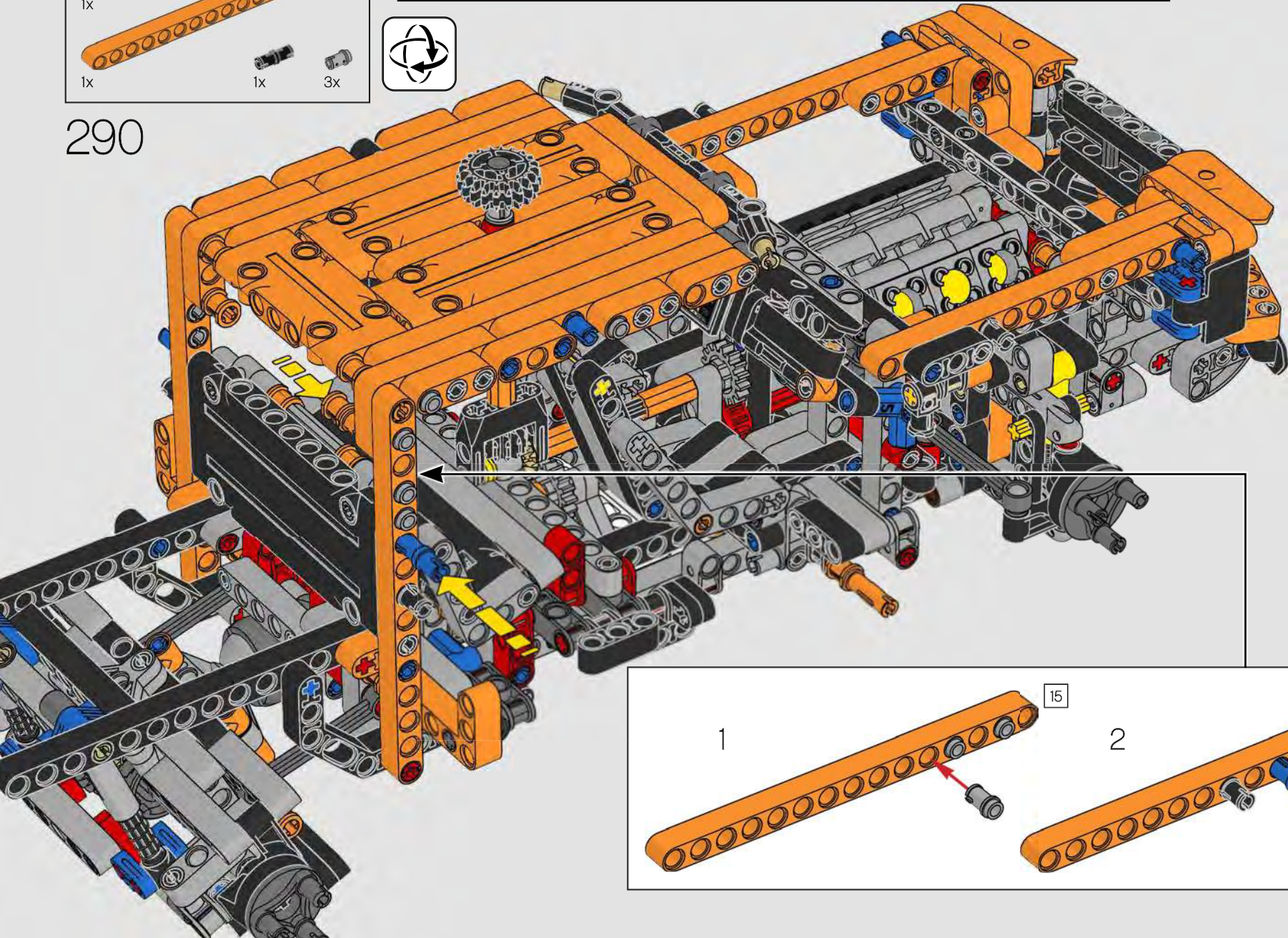

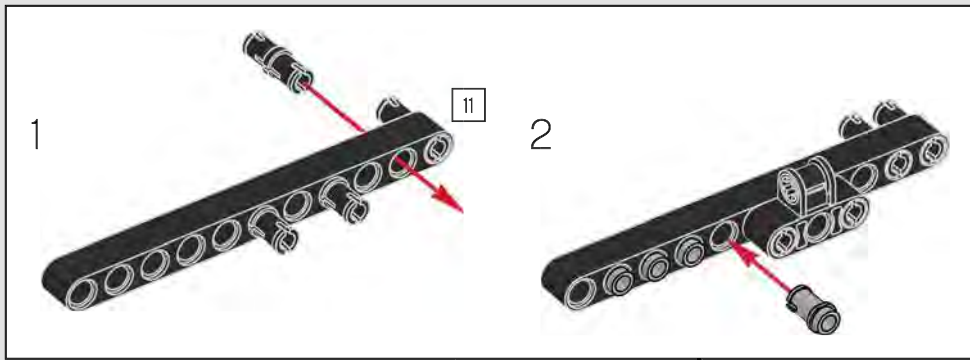
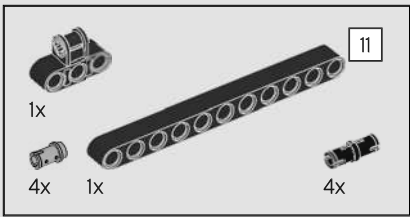

291

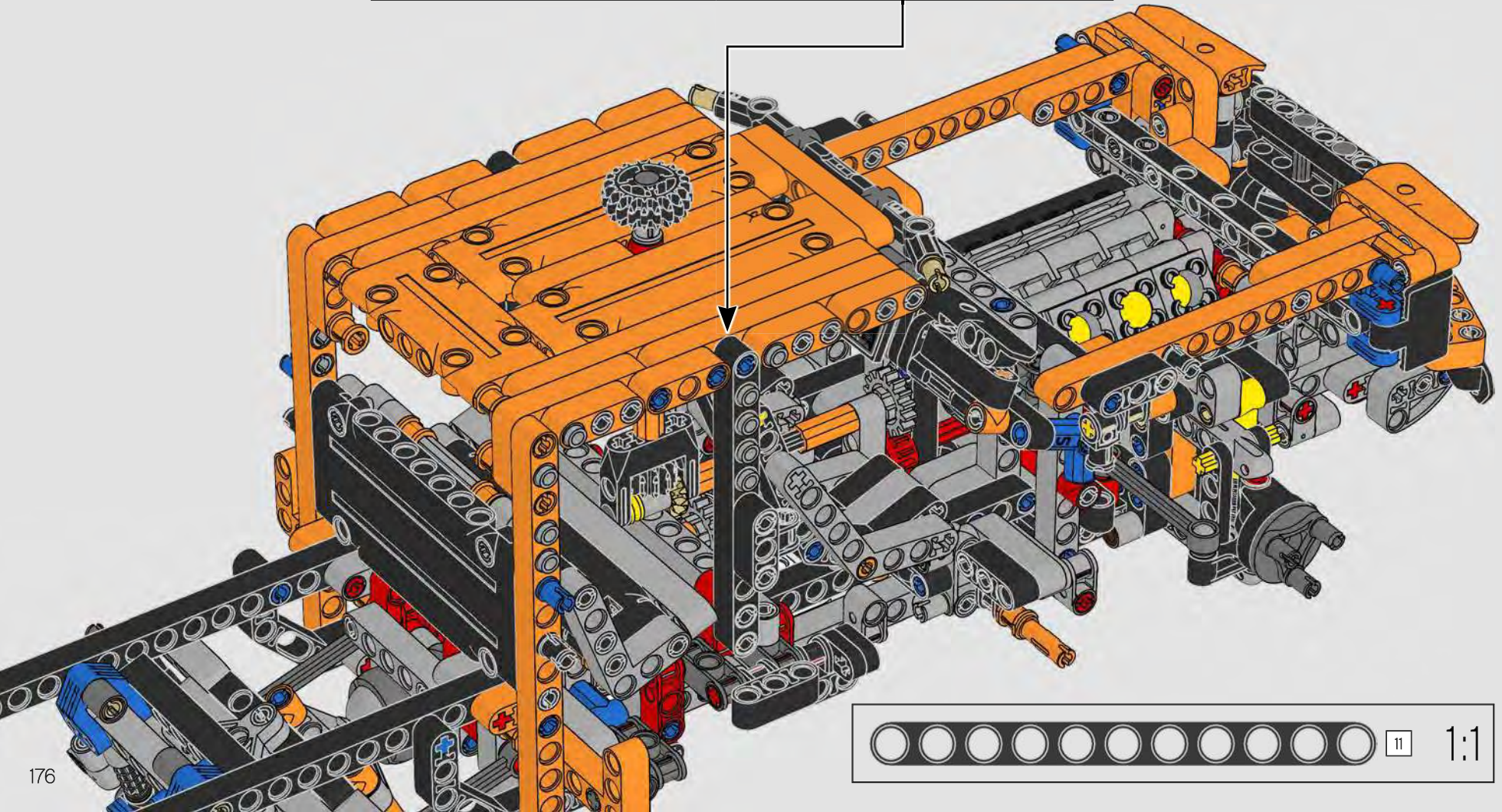





292

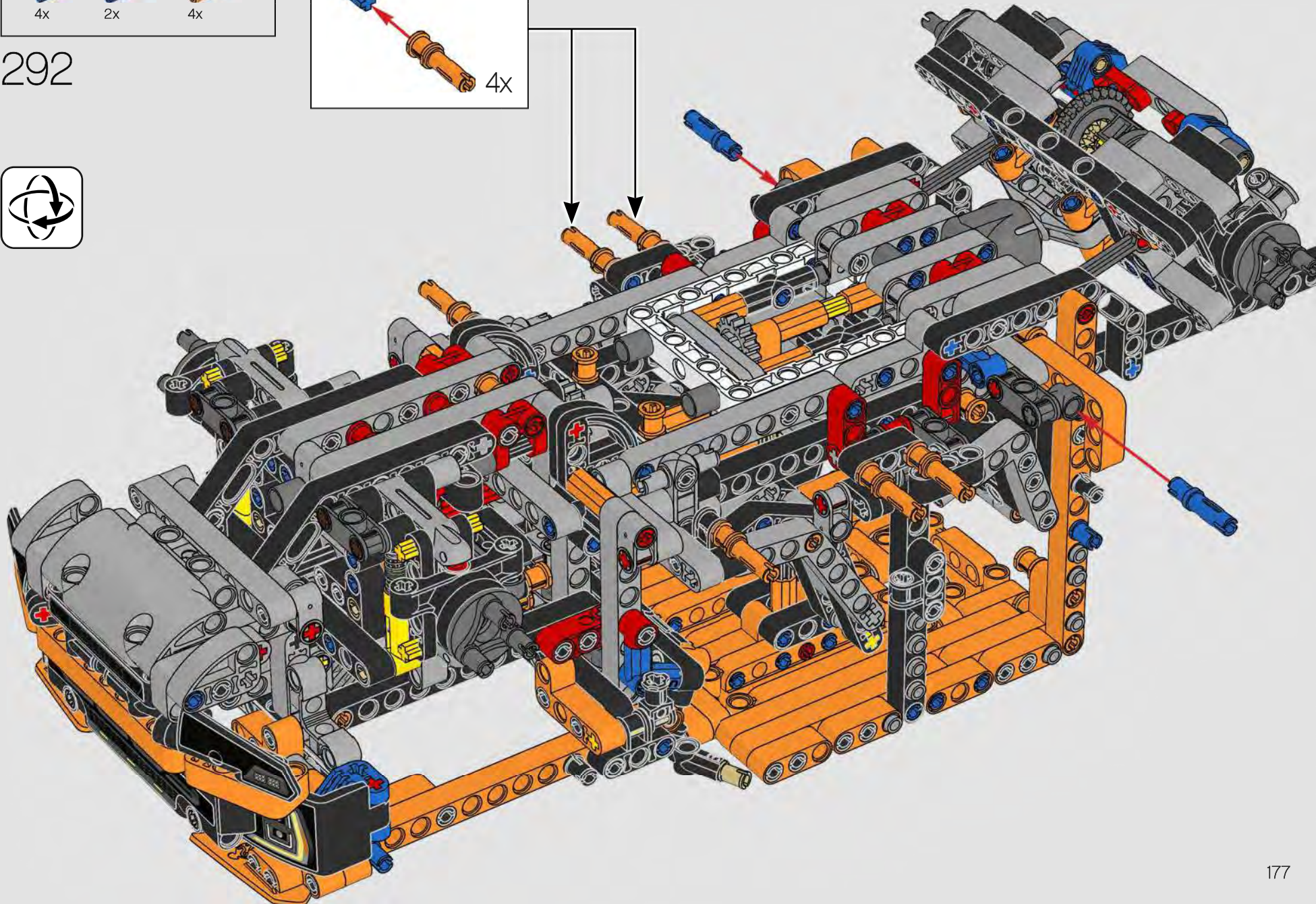
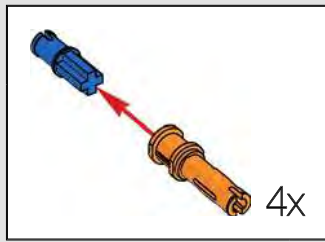

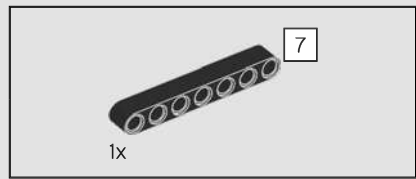

293

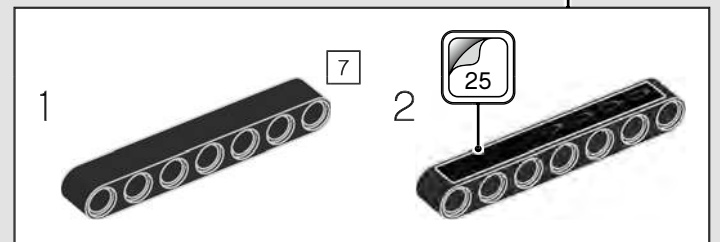
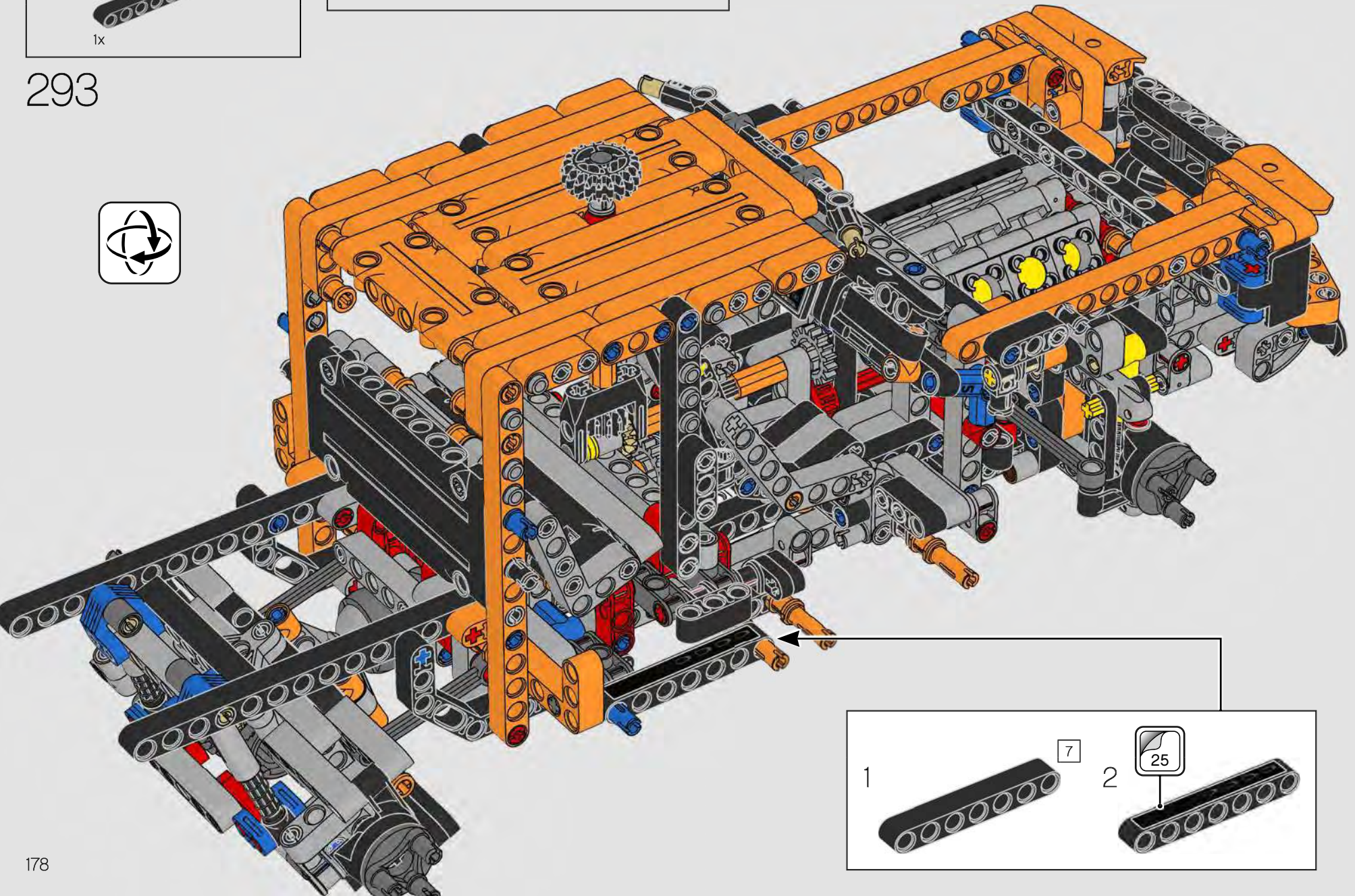

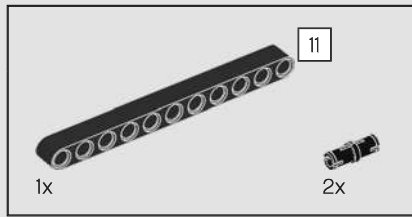

294

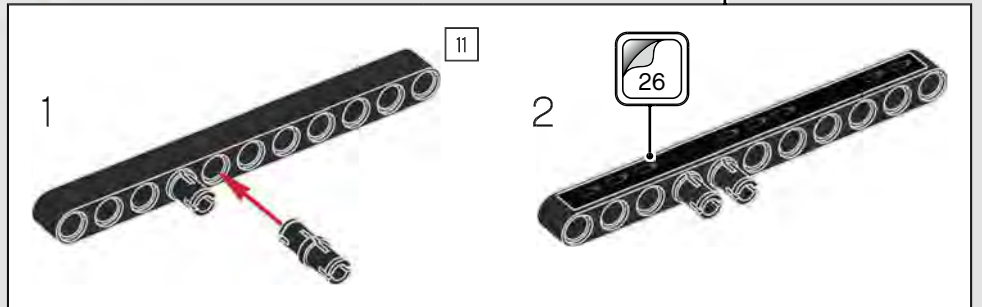
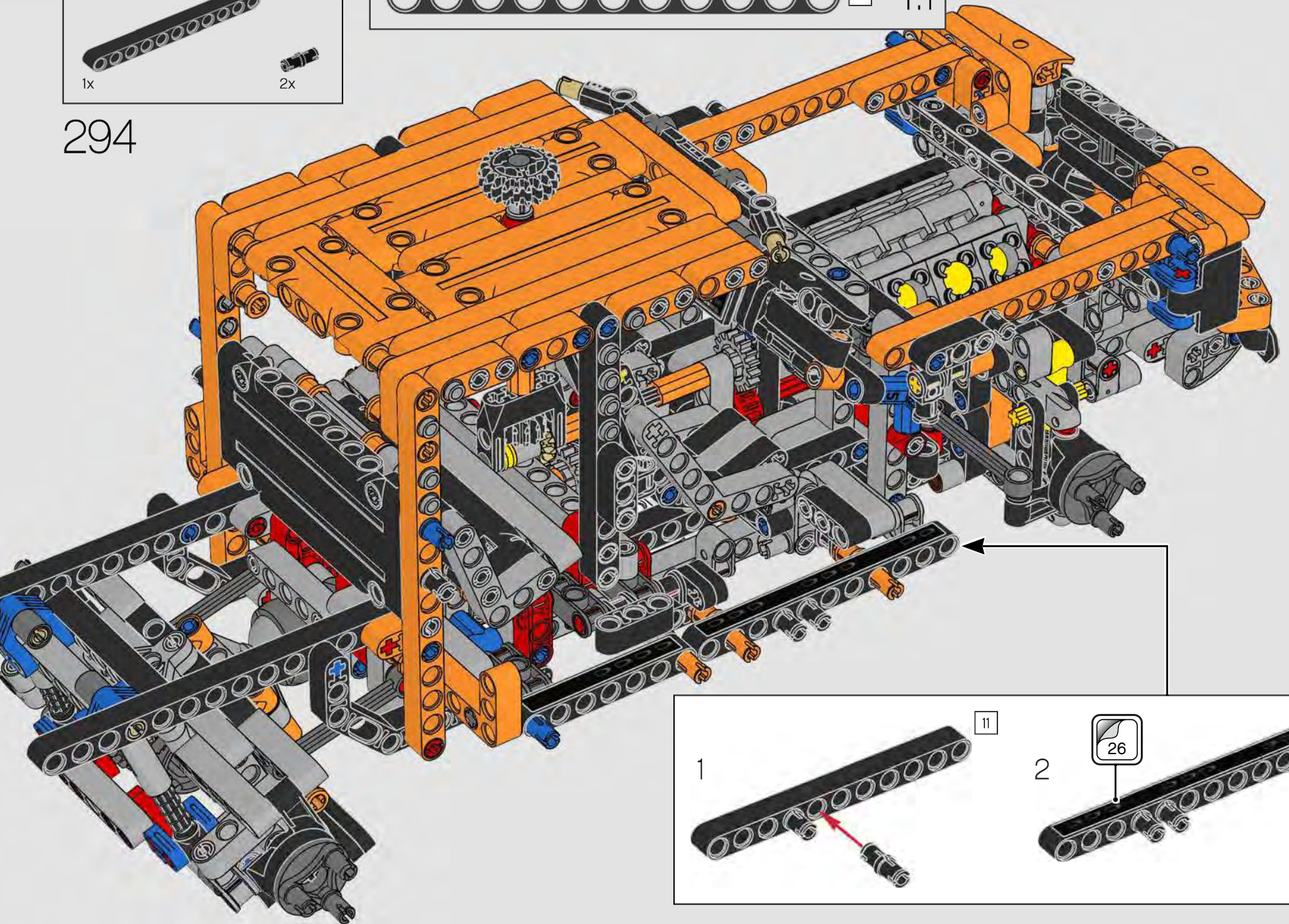

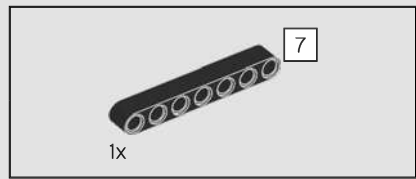

295

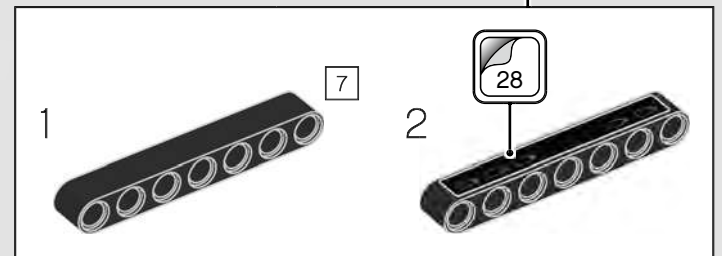
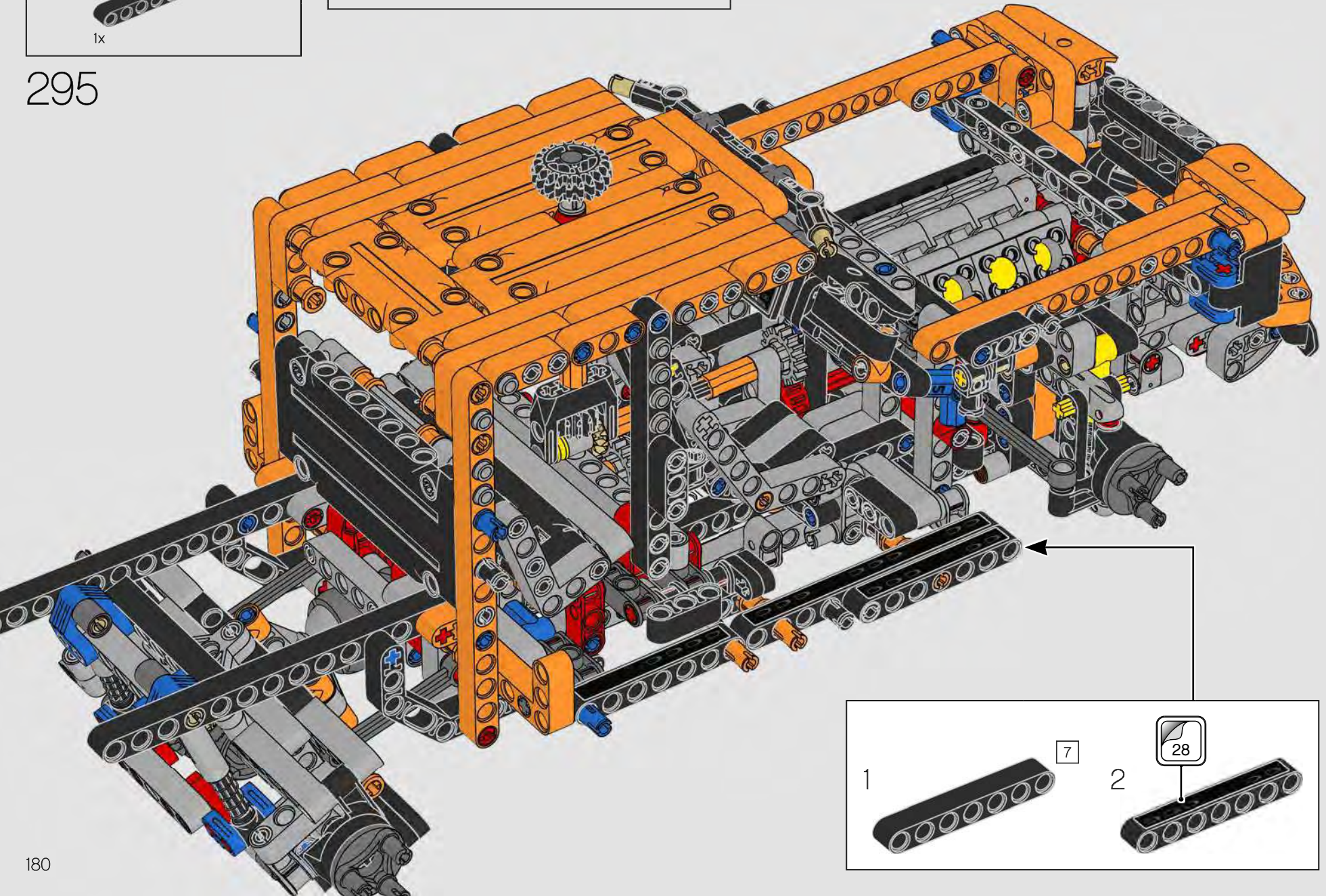

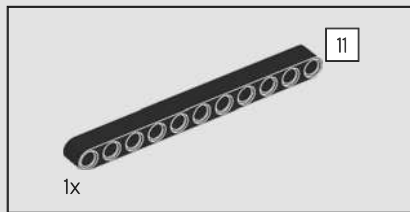

296

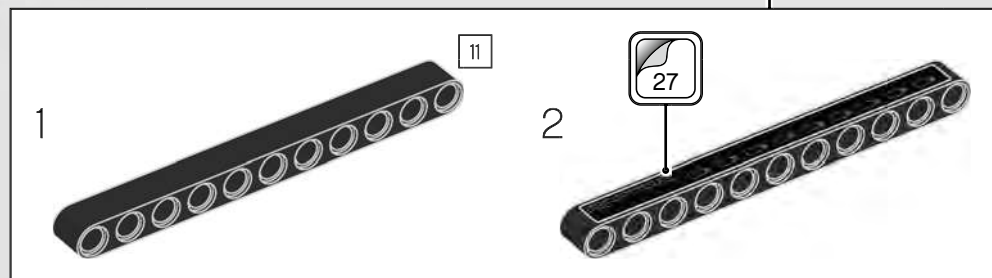
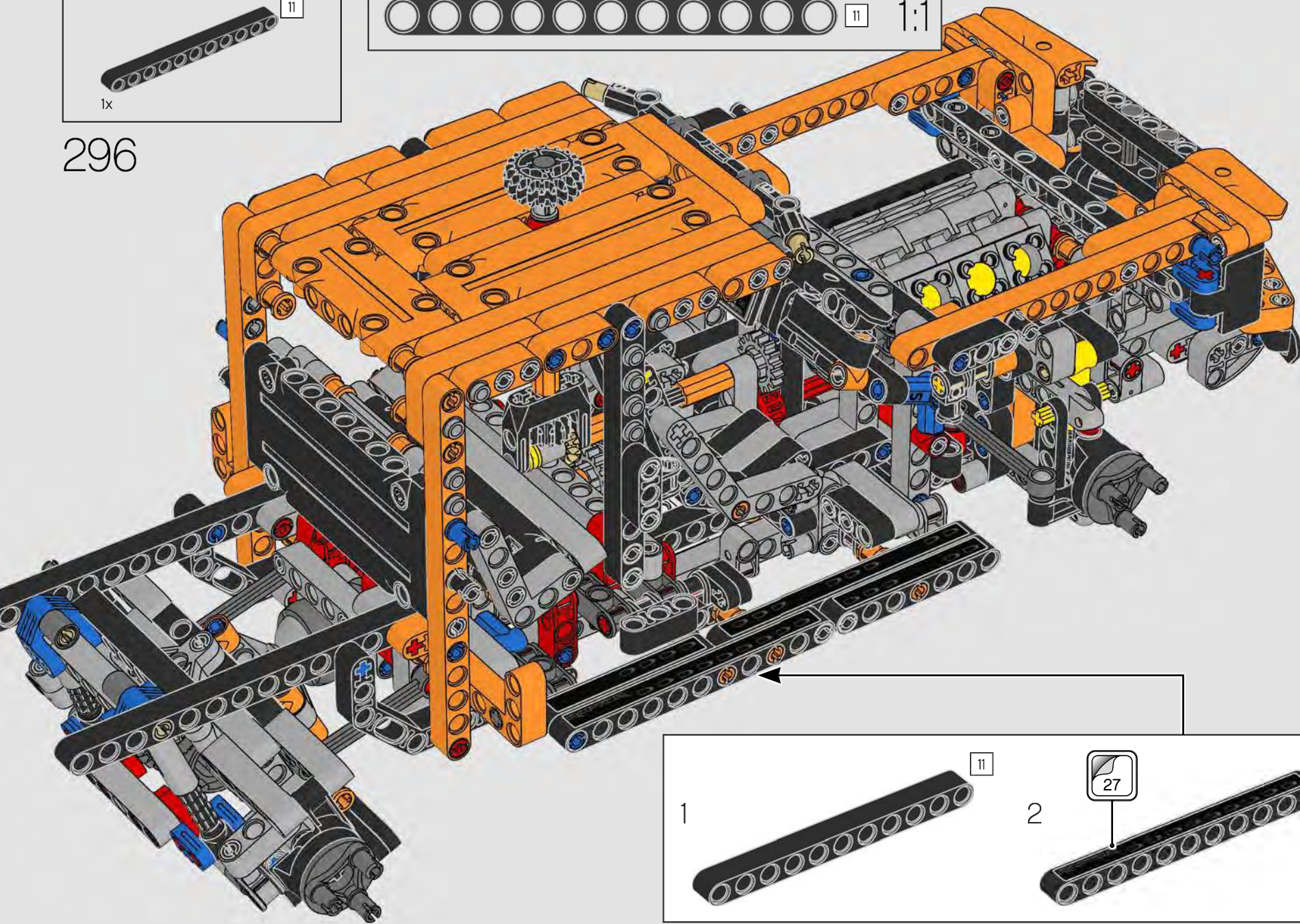

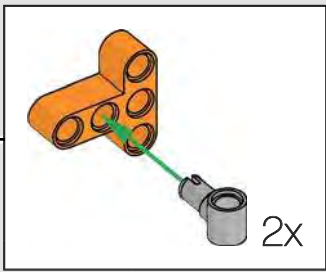
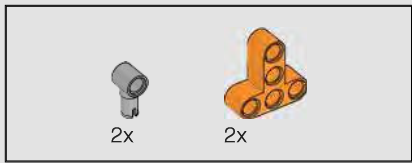

297

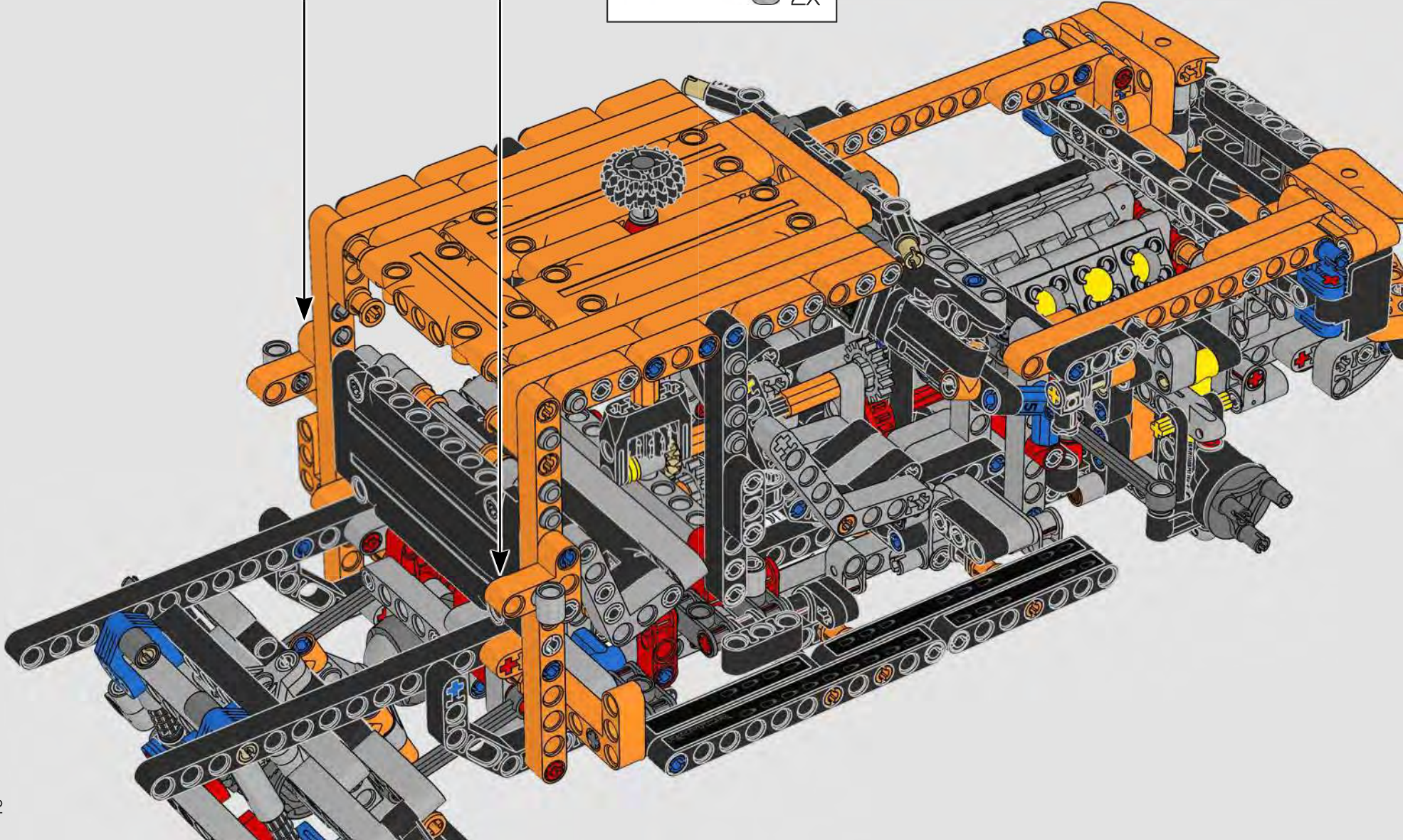

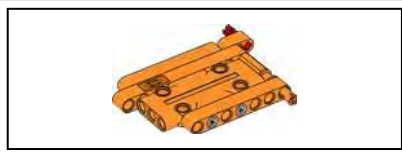

298

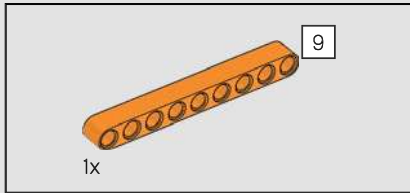

299

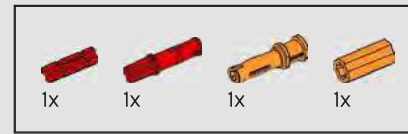
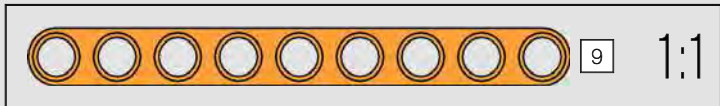
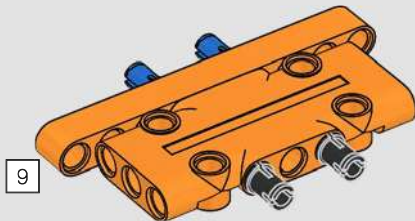

300

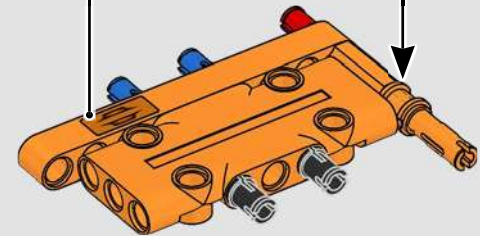
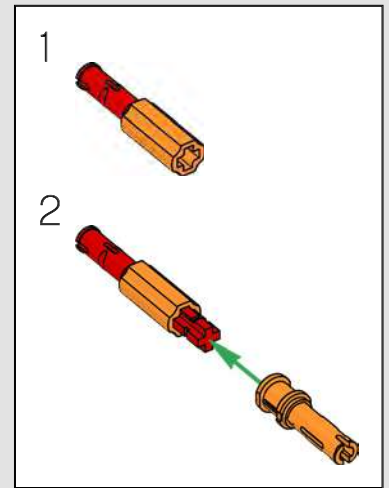



301

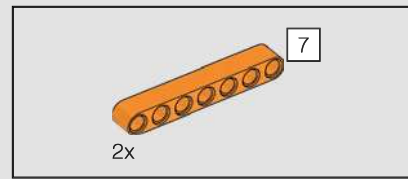
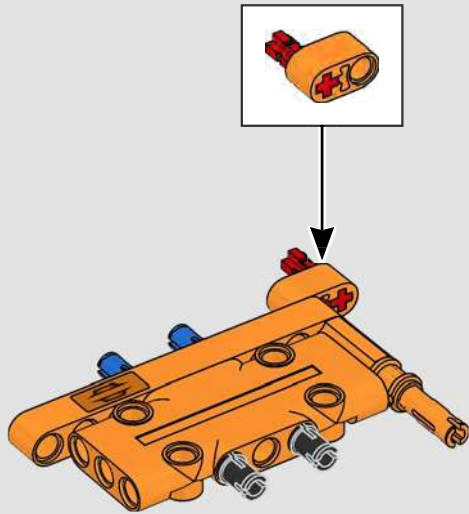

302

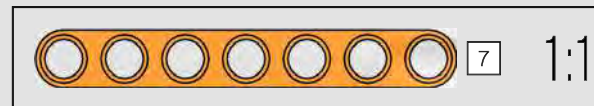
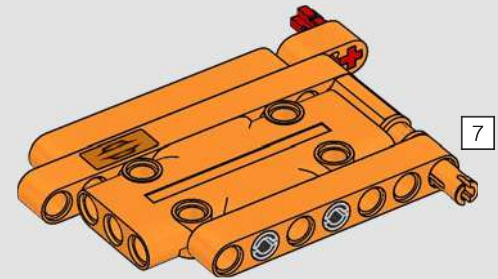



303

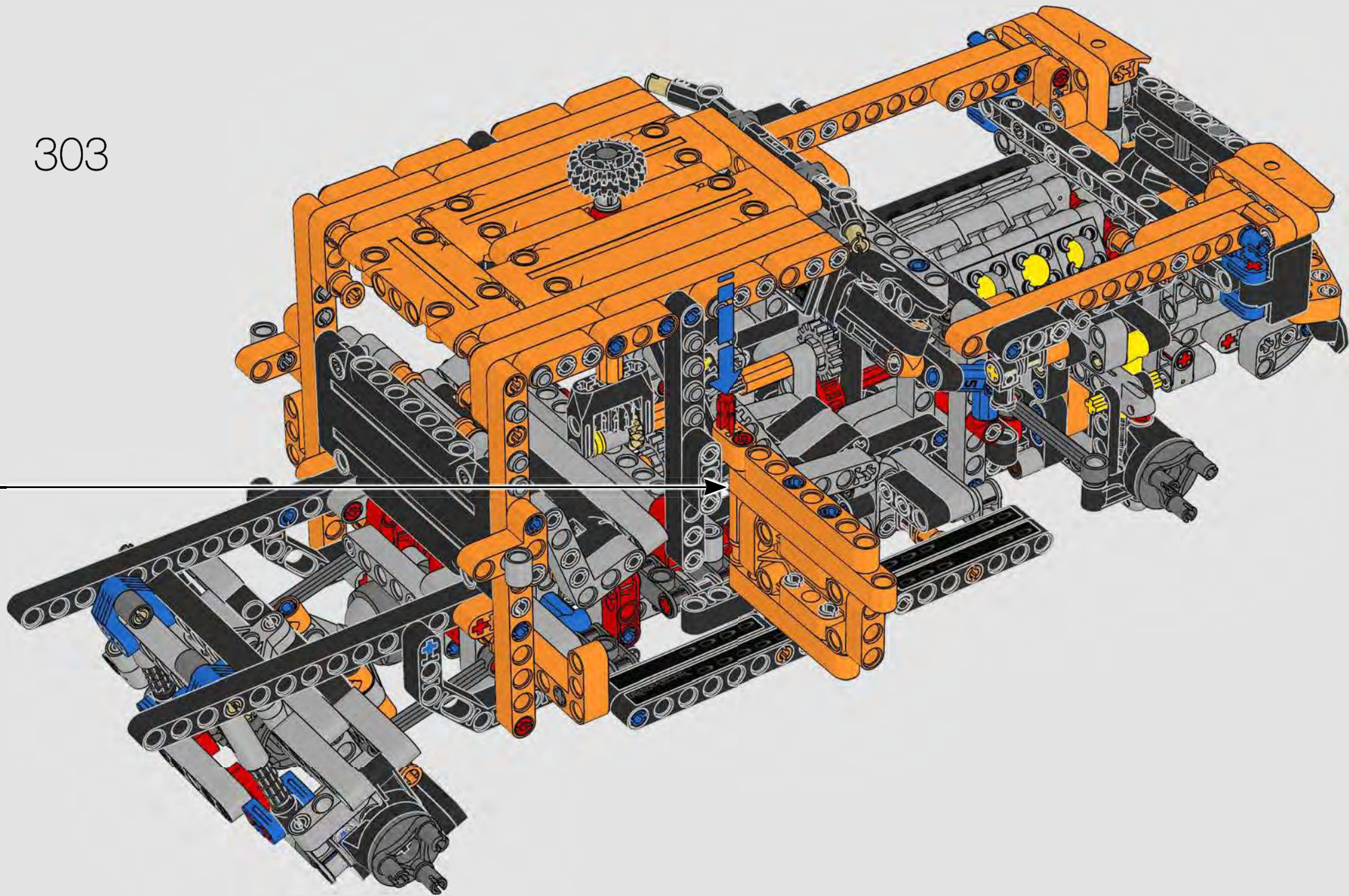

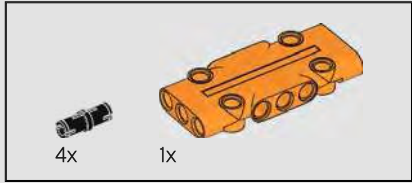
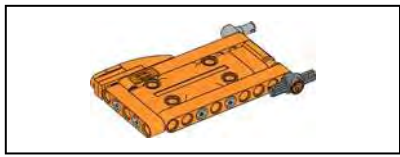

304

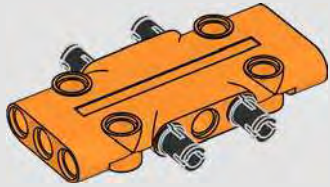

305

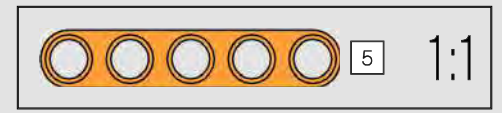
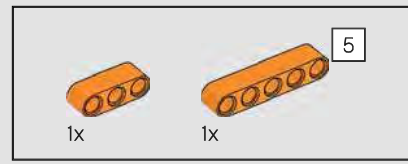
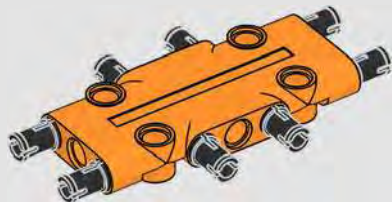

306

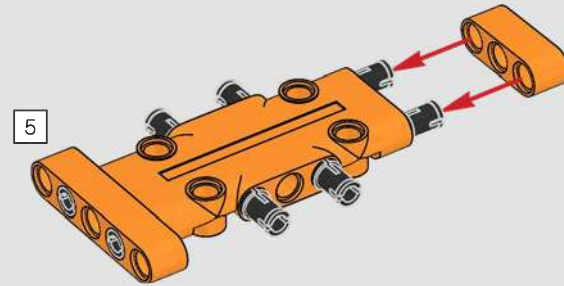

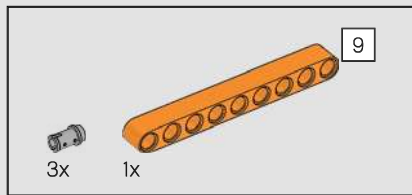

307

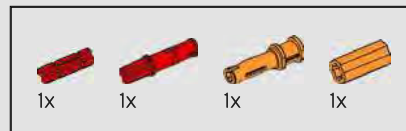
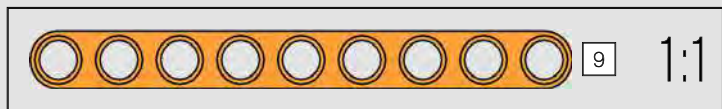
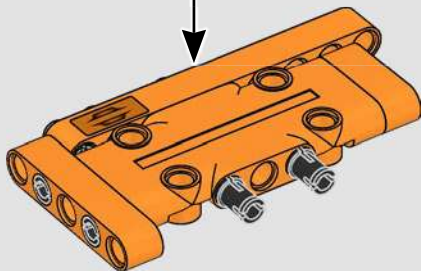
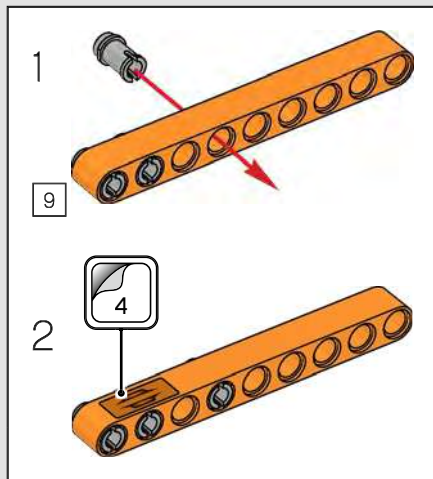

308

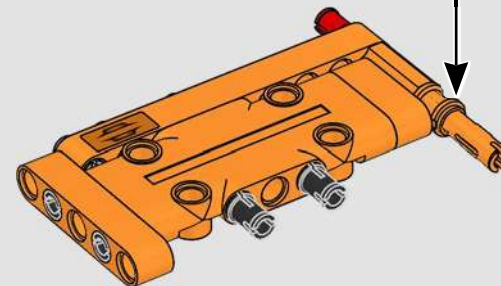
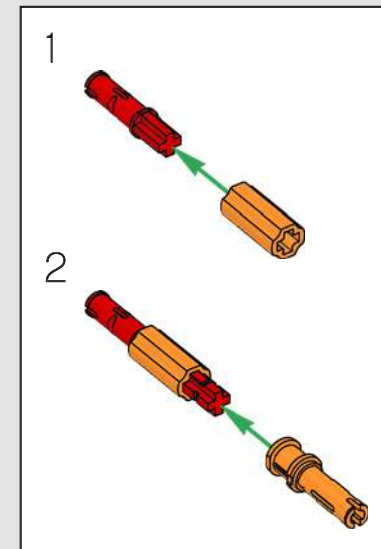

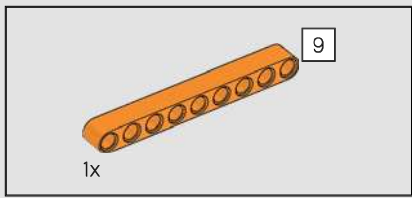

309

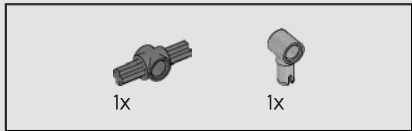
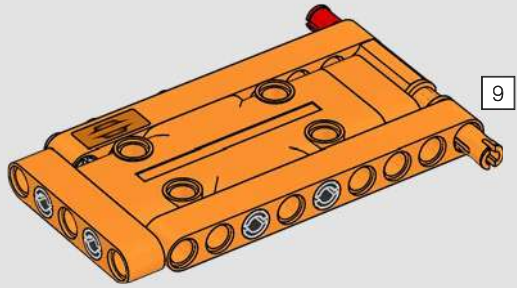

310

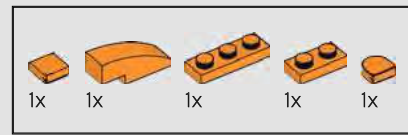
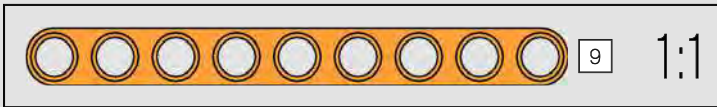
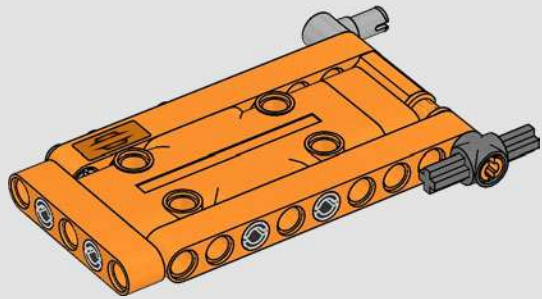

311

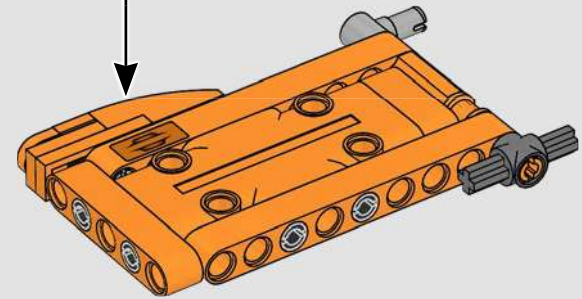
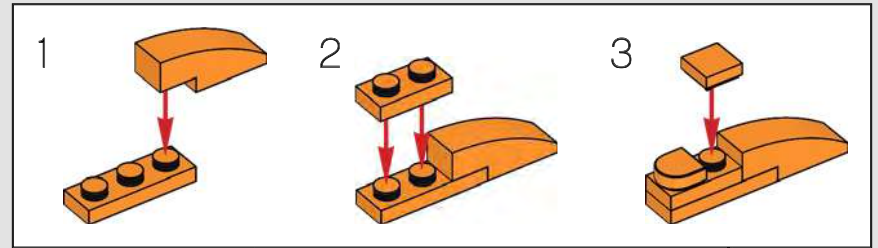

312

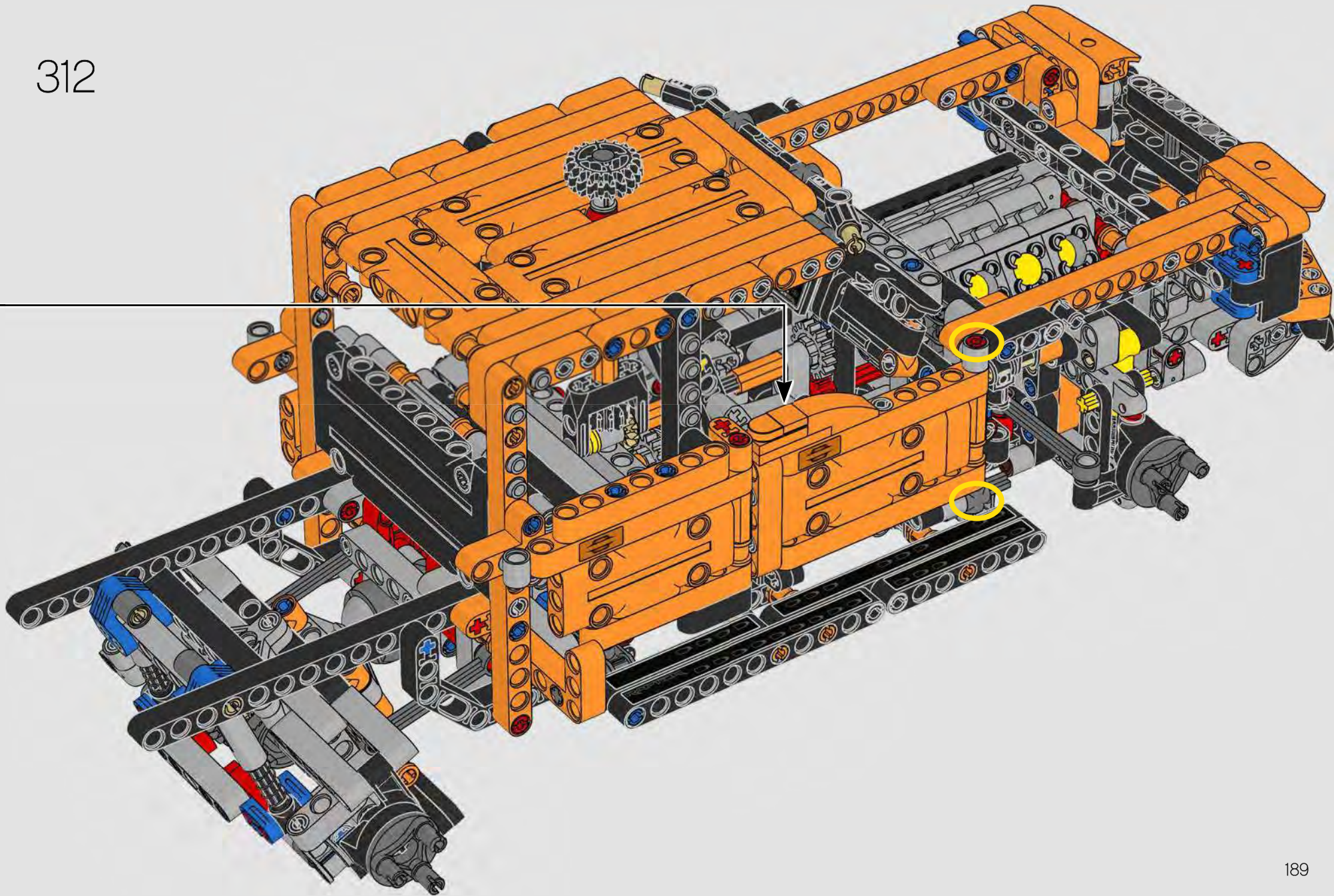

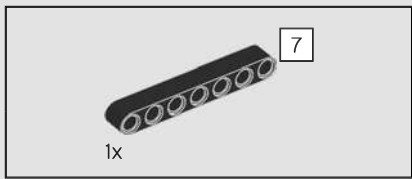

313

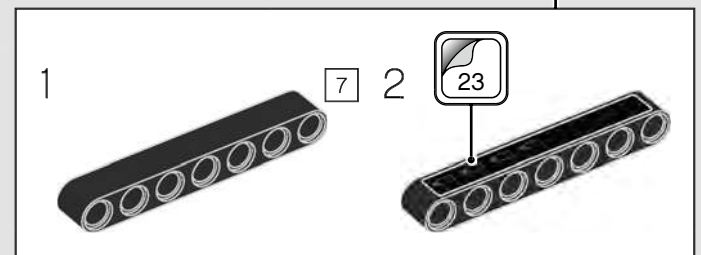
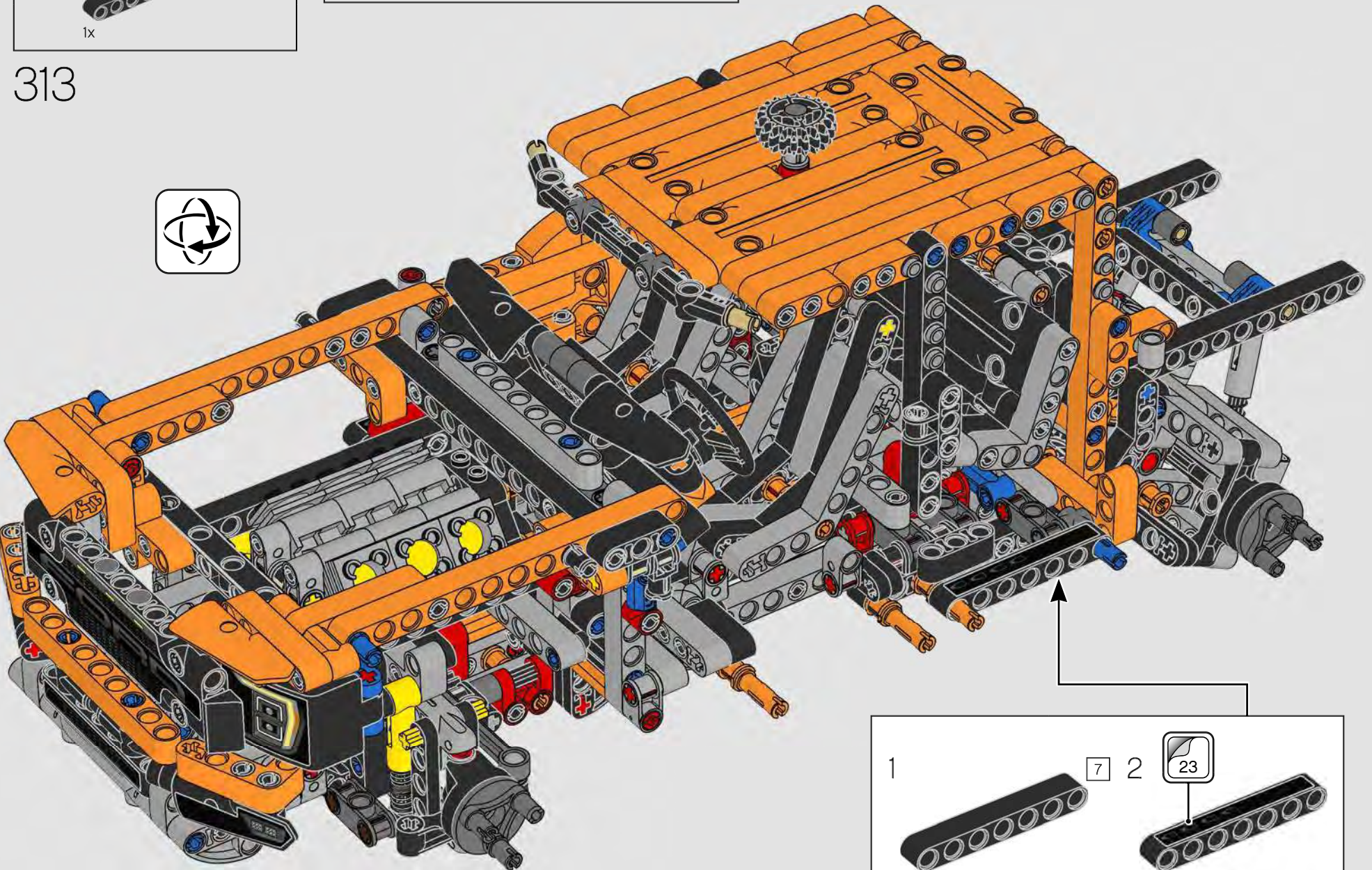

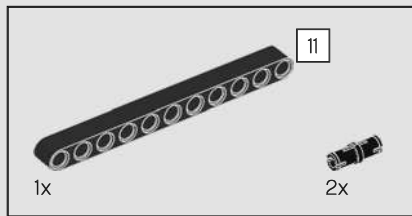

314

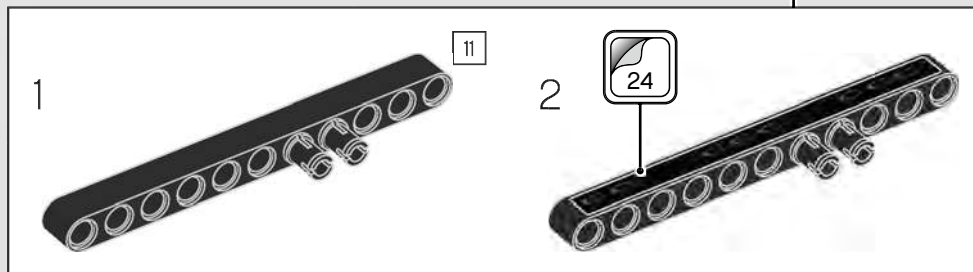
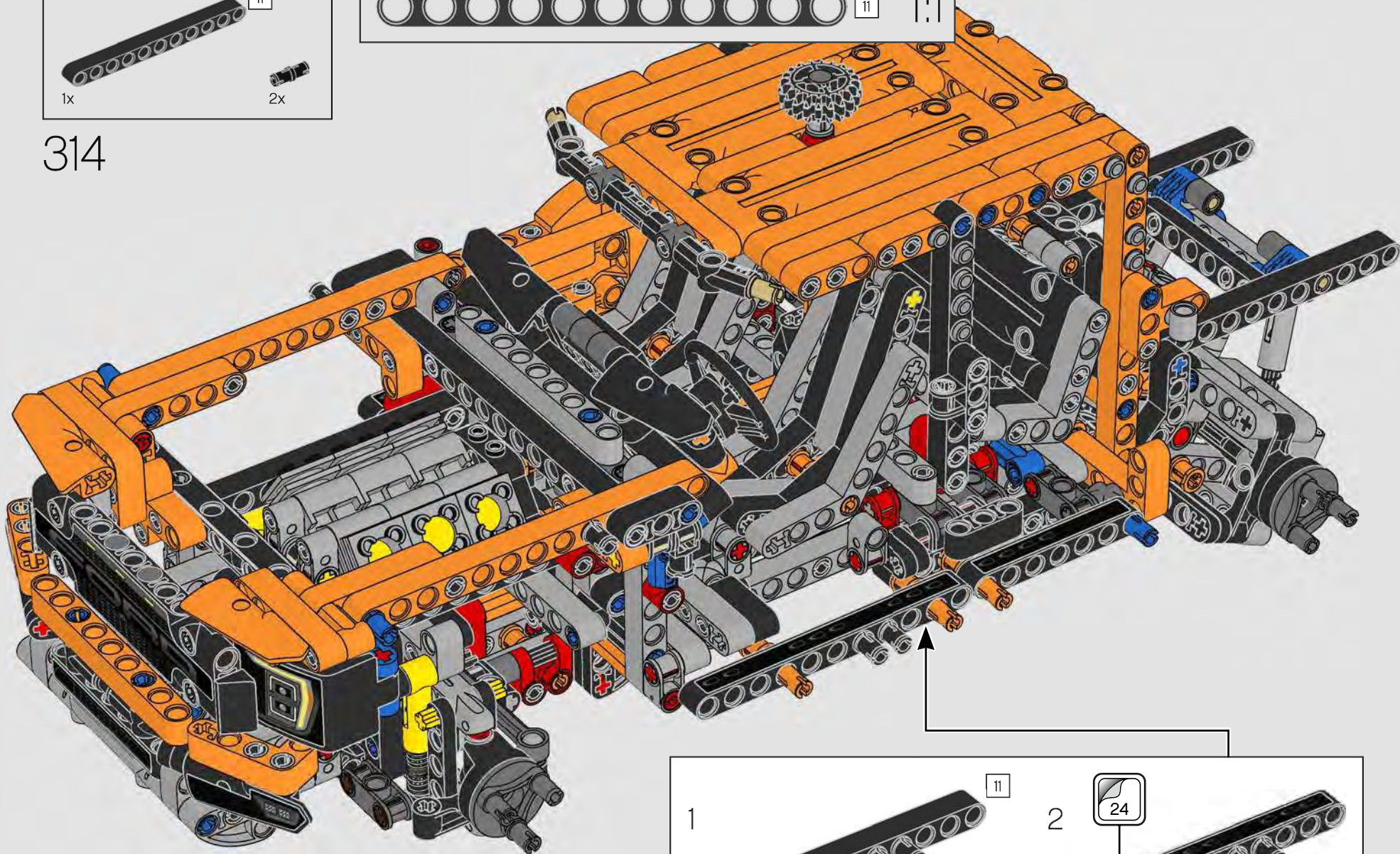

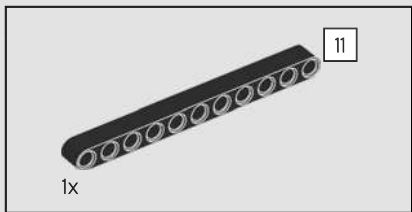

315

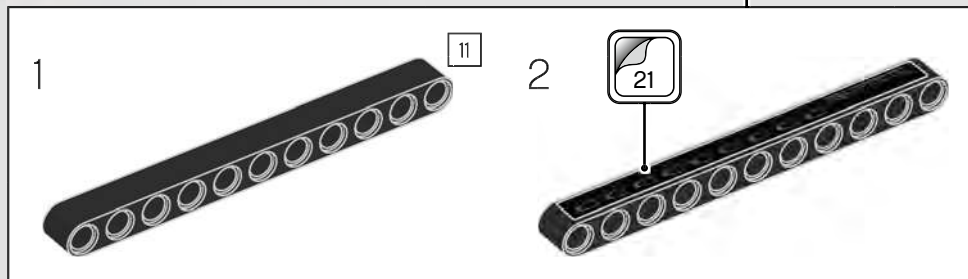
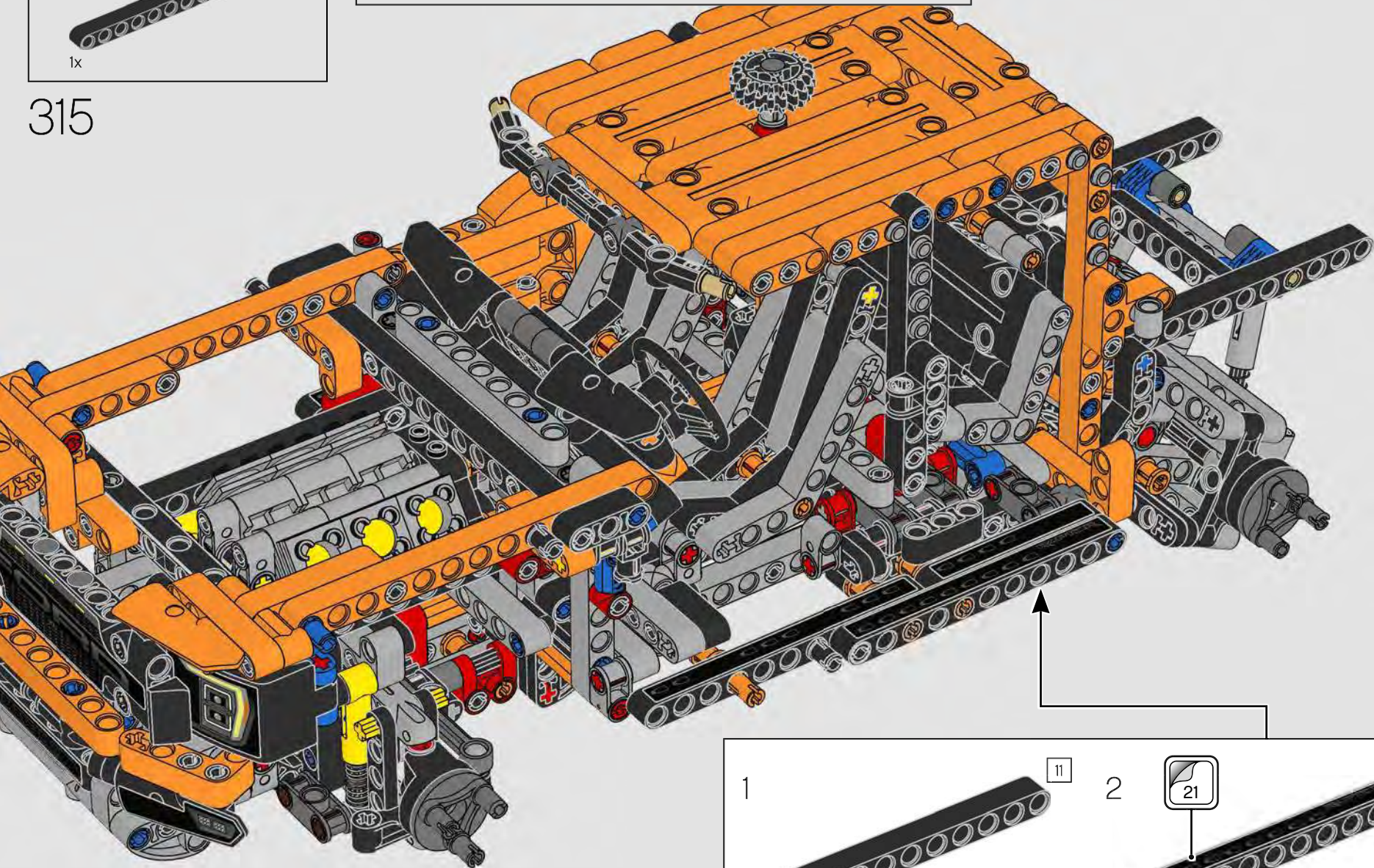



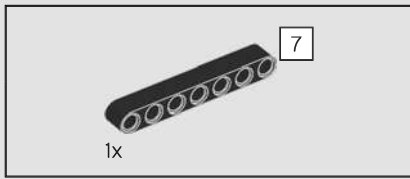

316

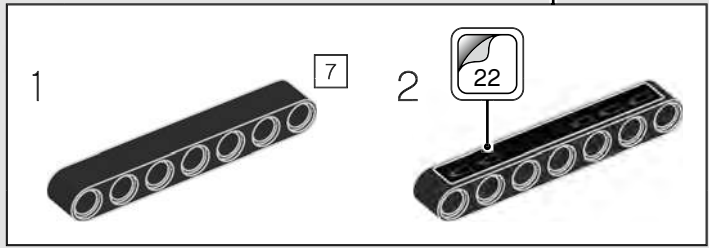
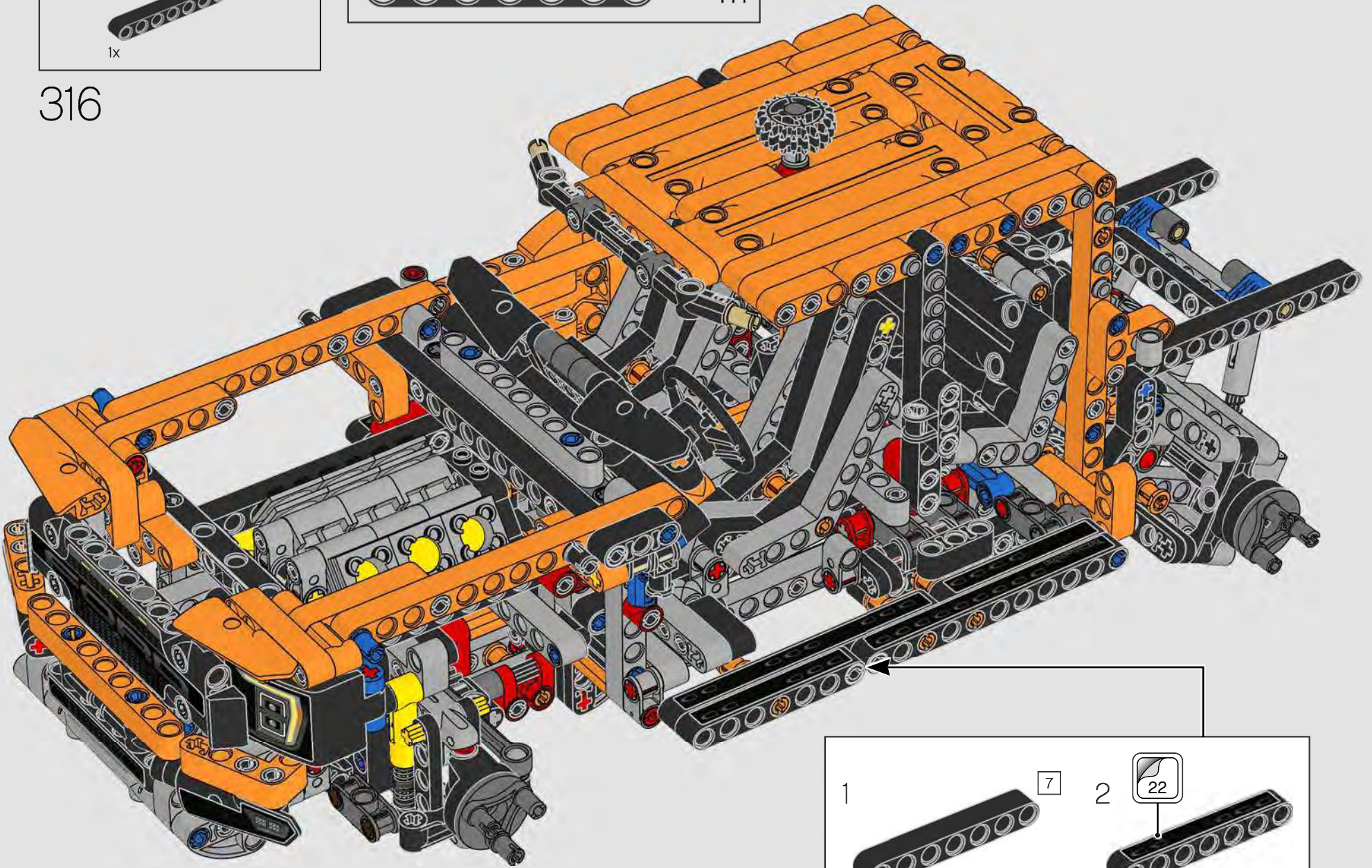

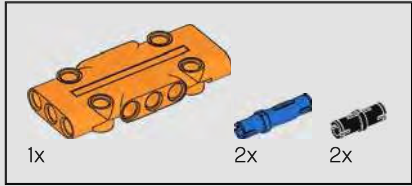
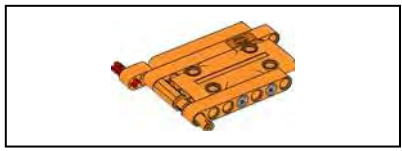

317

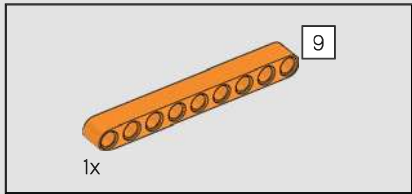
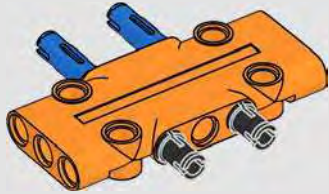

318

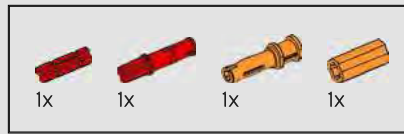
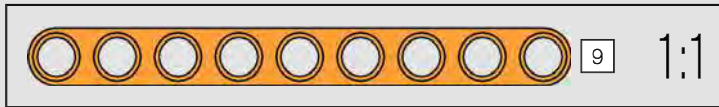
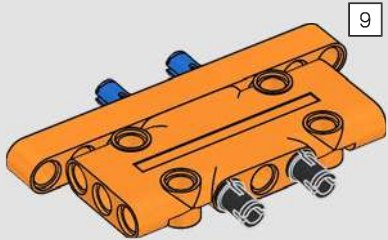

319

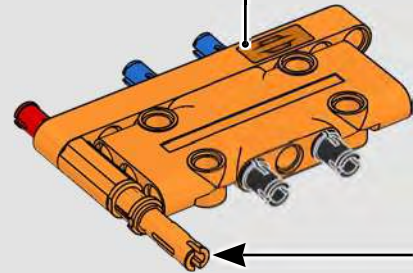
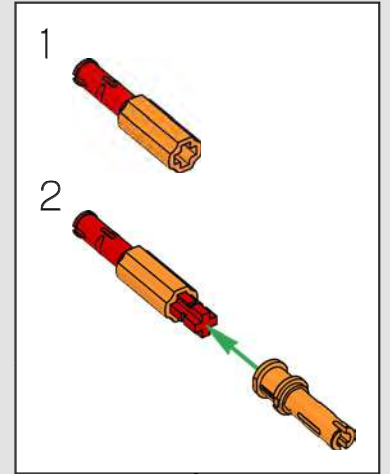



320

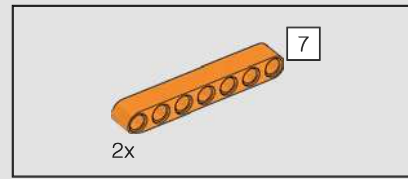
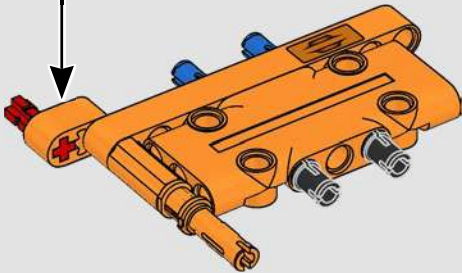

321

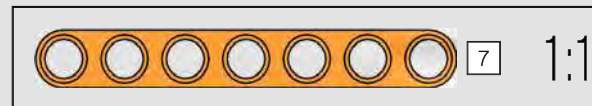
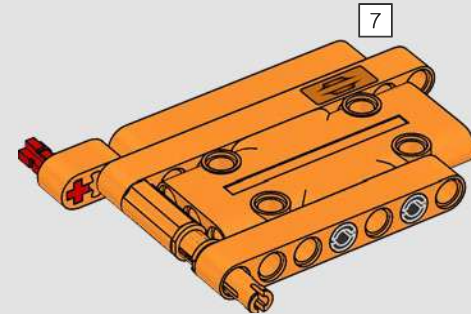

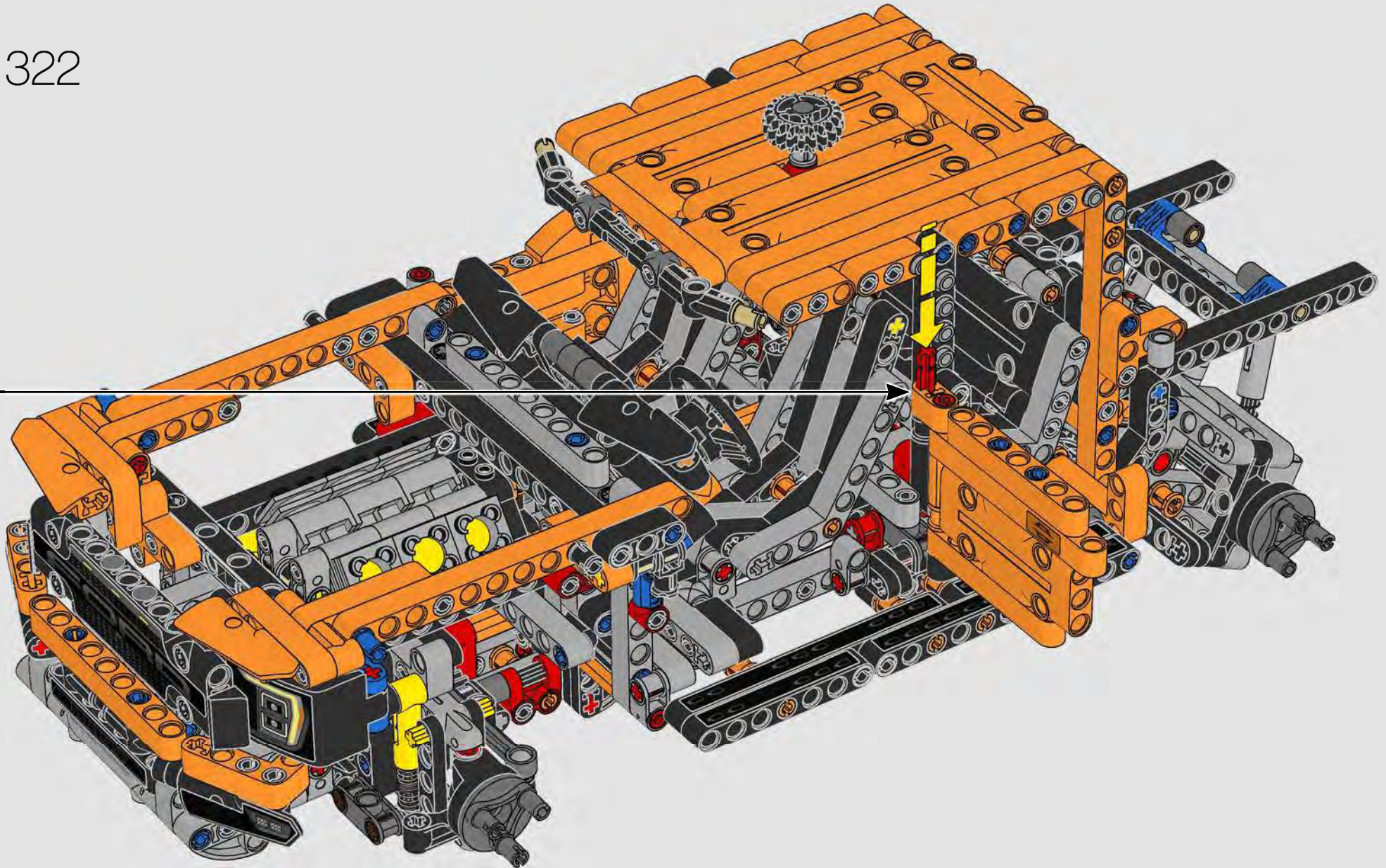

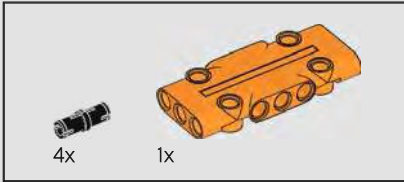
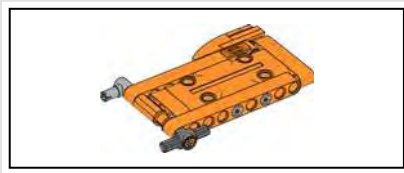

323

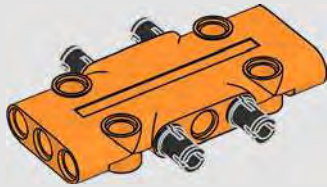

324

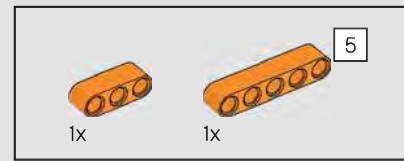
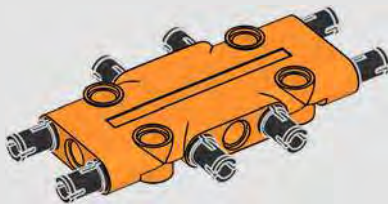

325

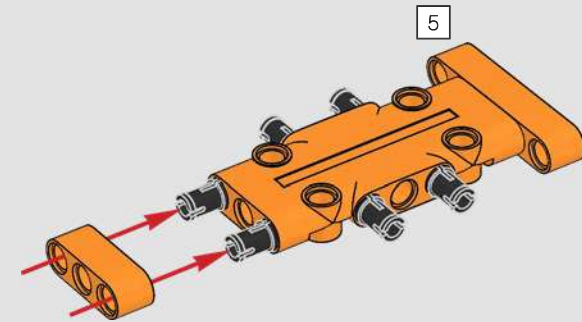

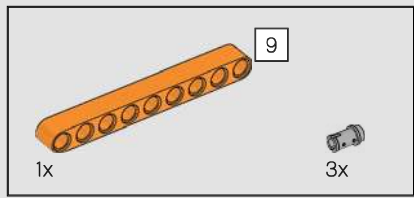

326

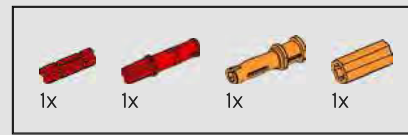
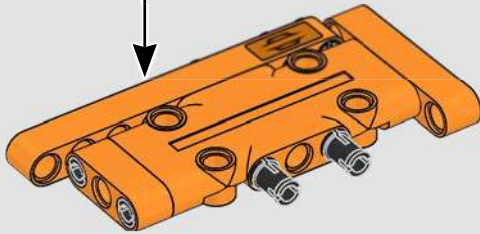
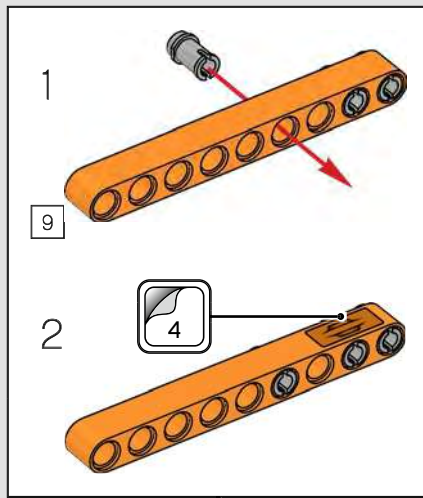

327

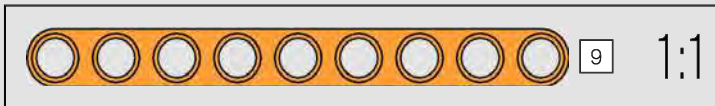
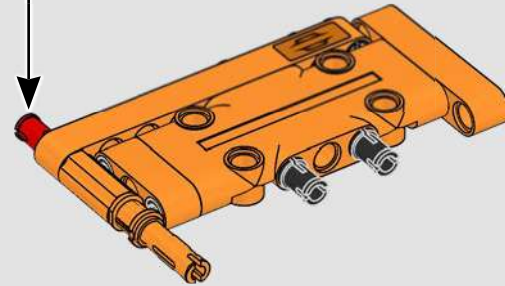
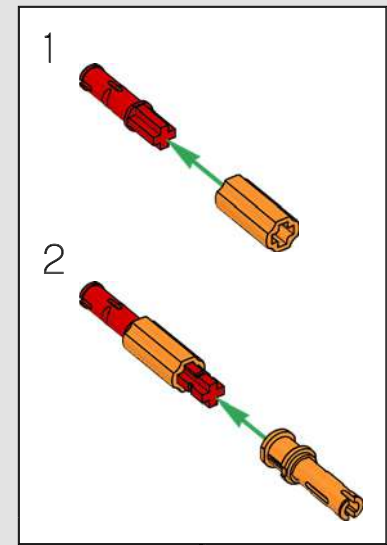

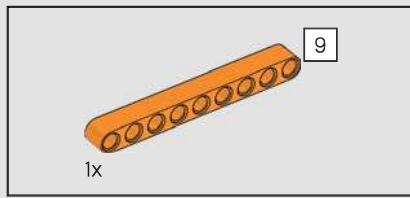

328

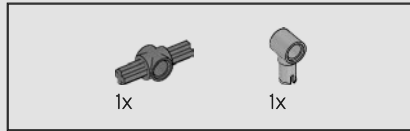
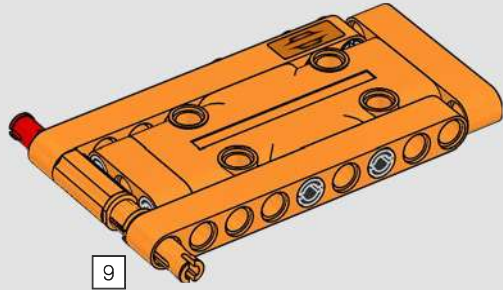

329

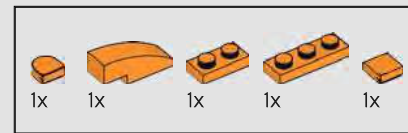
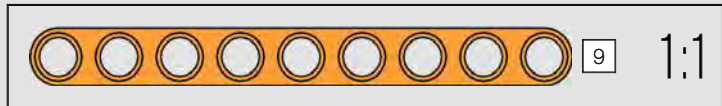
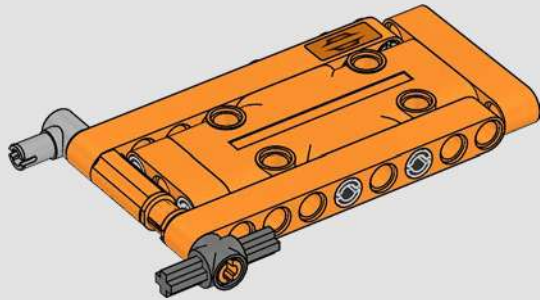

330

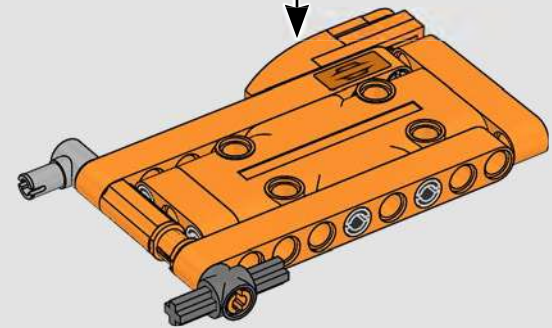
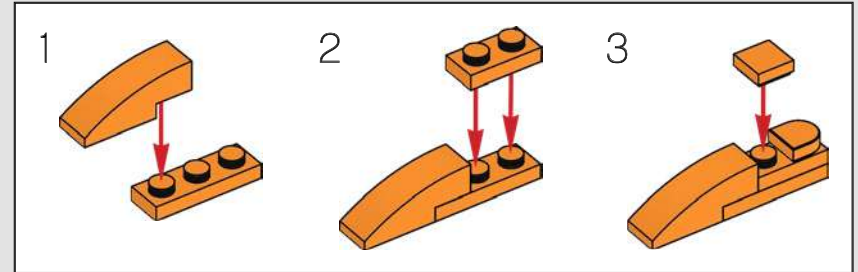

331

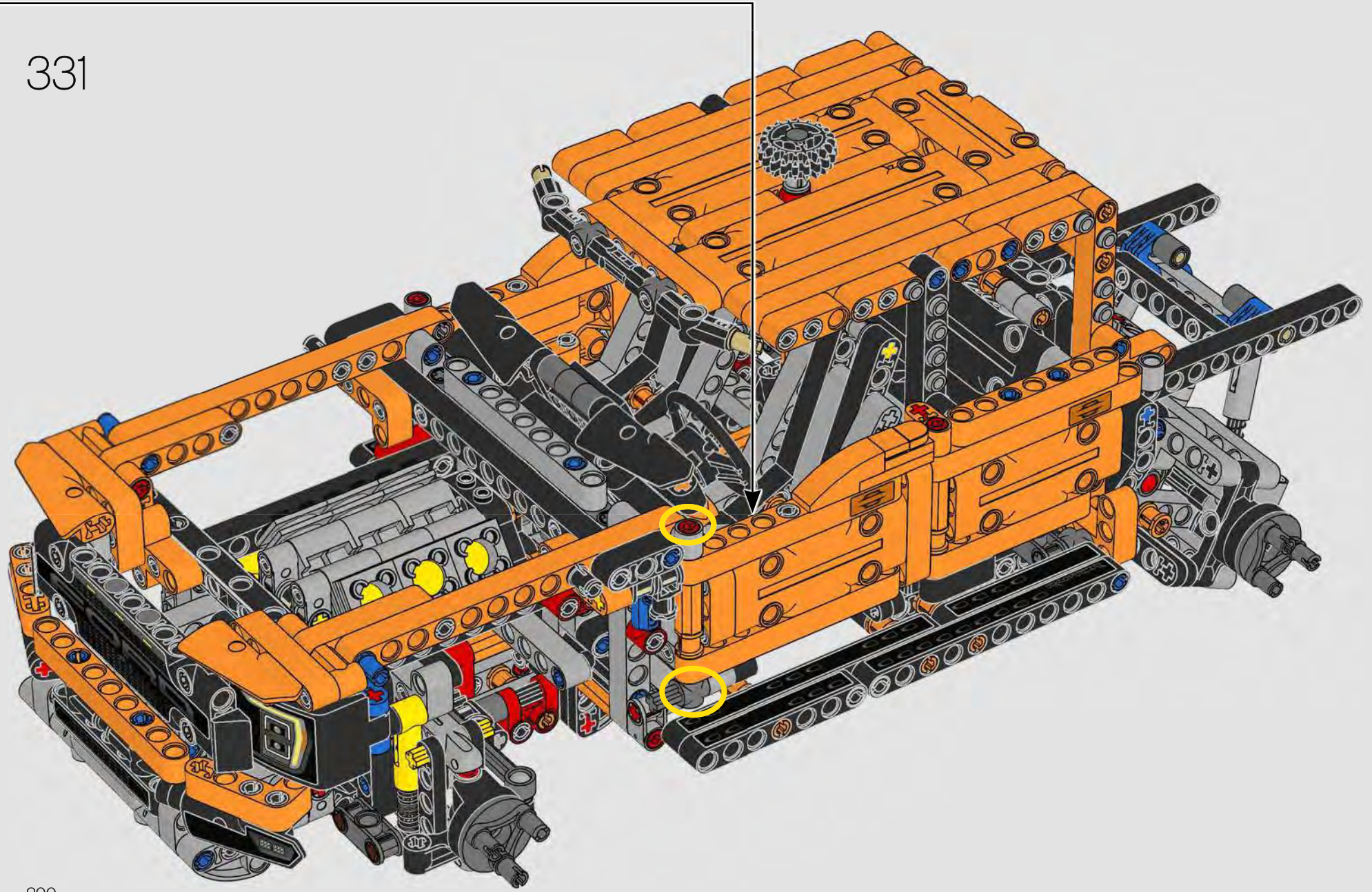



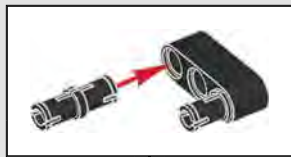
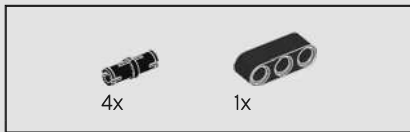

332

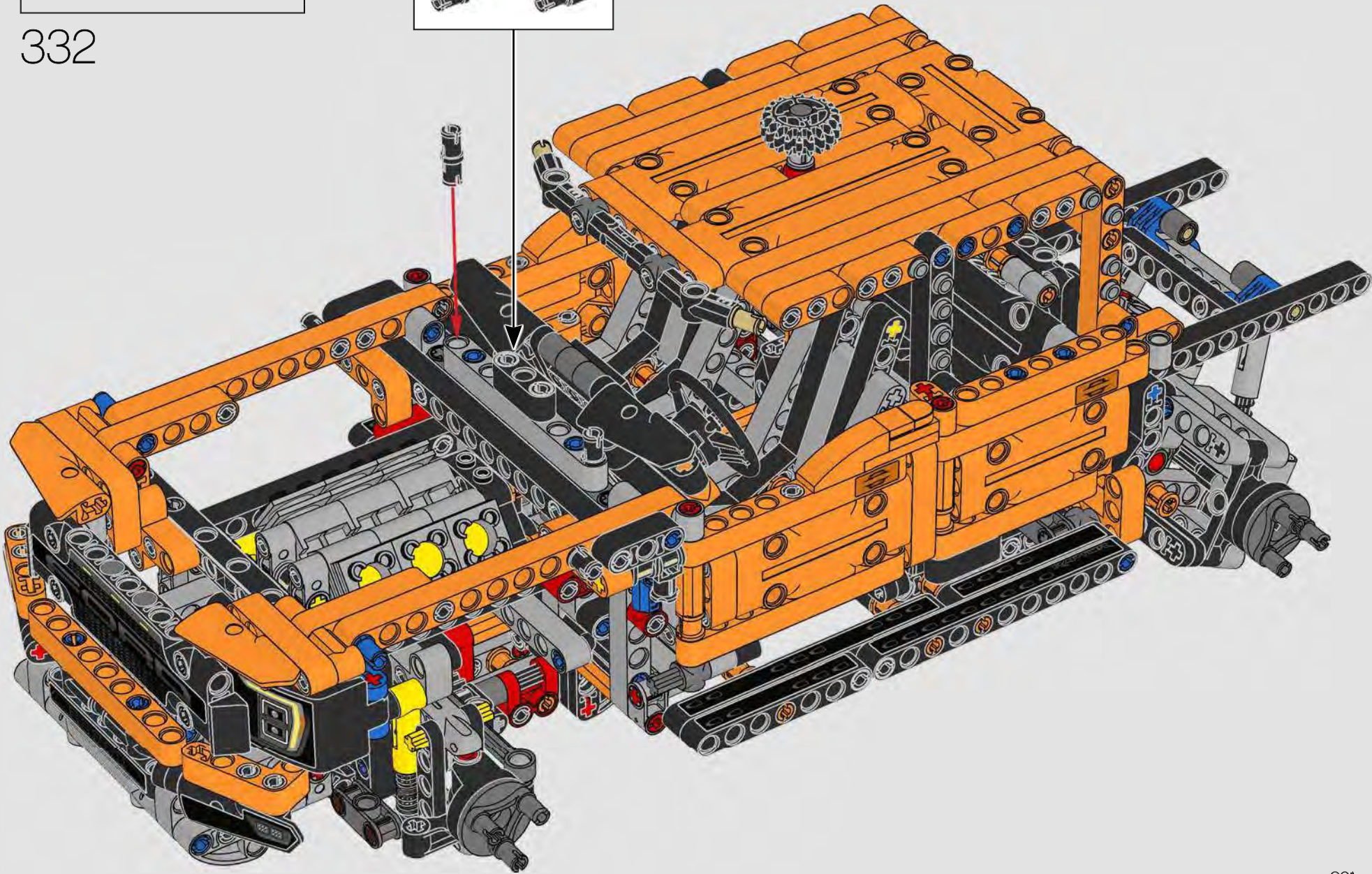

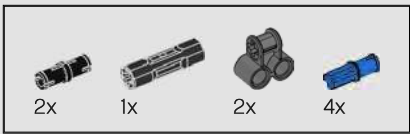

333

1

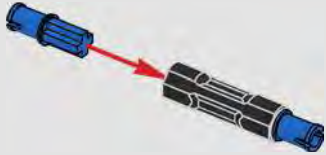

2

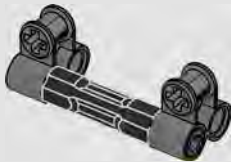

3



4

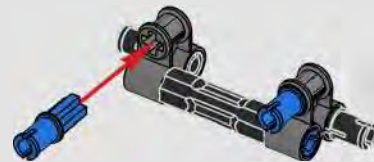

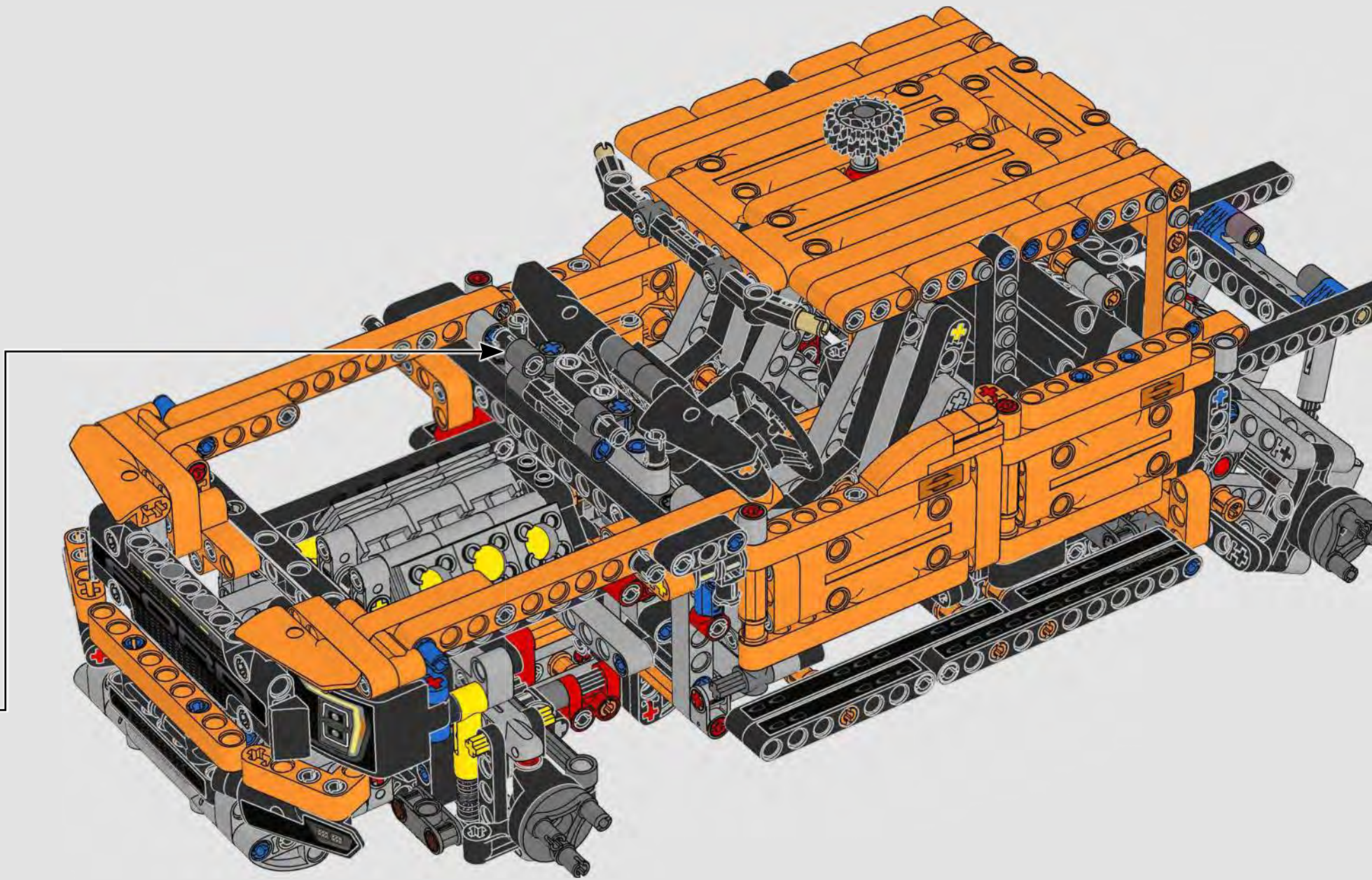

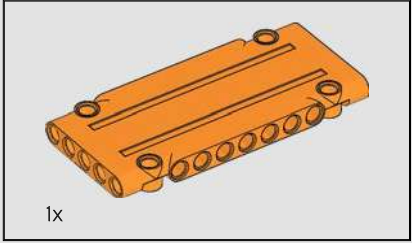
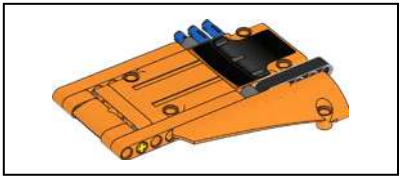

334

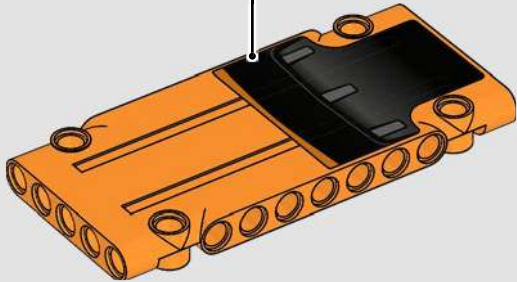

335

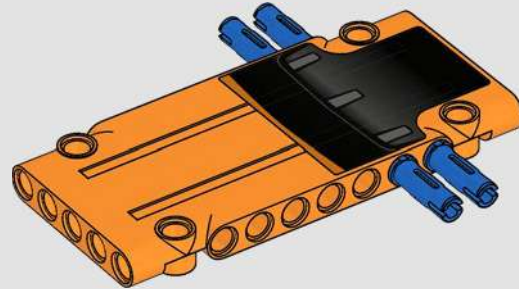

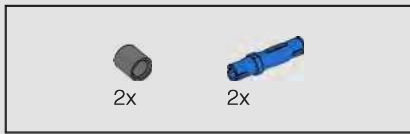

336

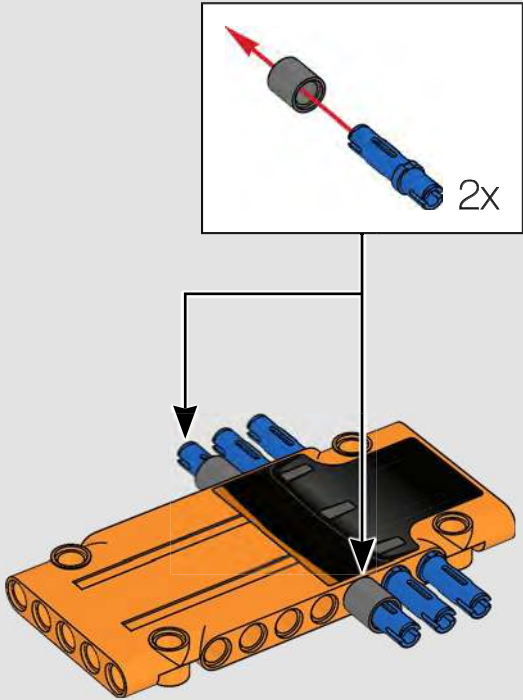

337

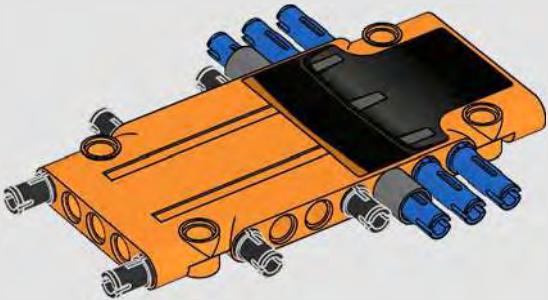

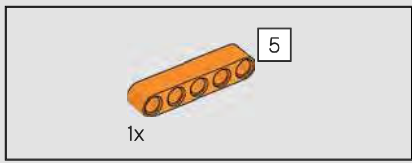

338

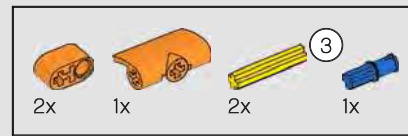
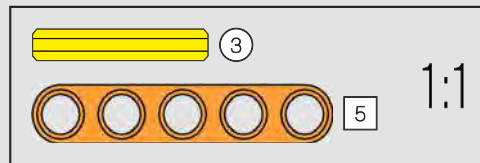
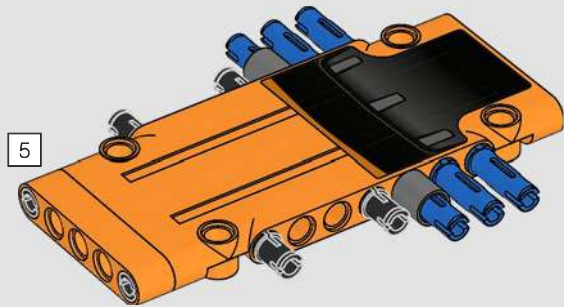

339

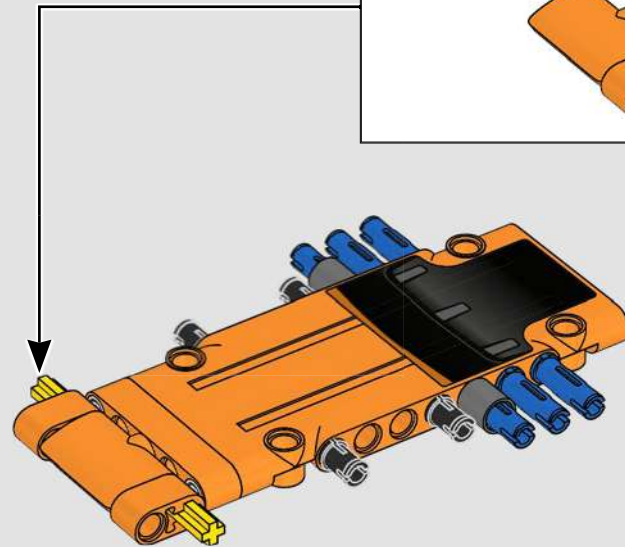
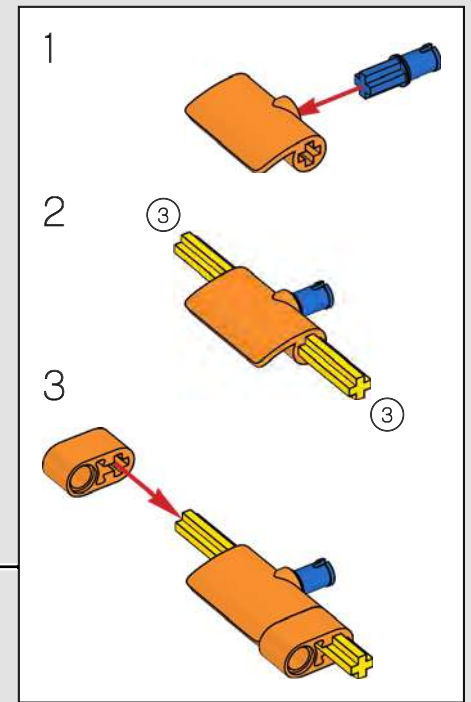

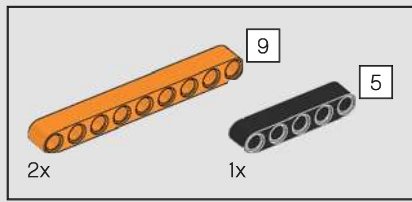

340

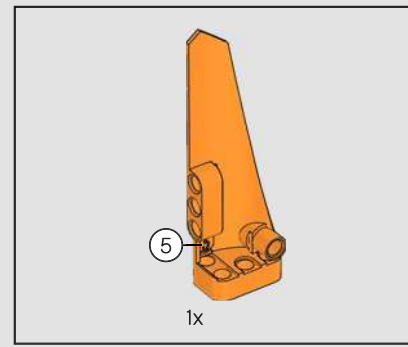
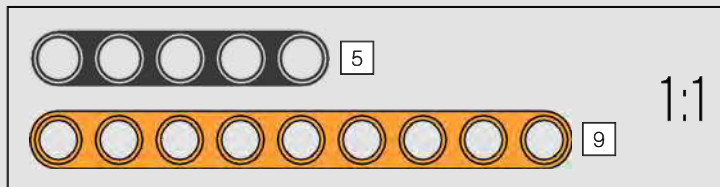
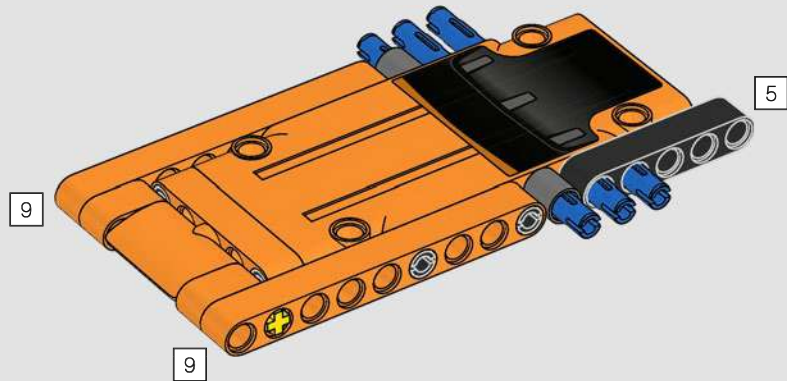

341

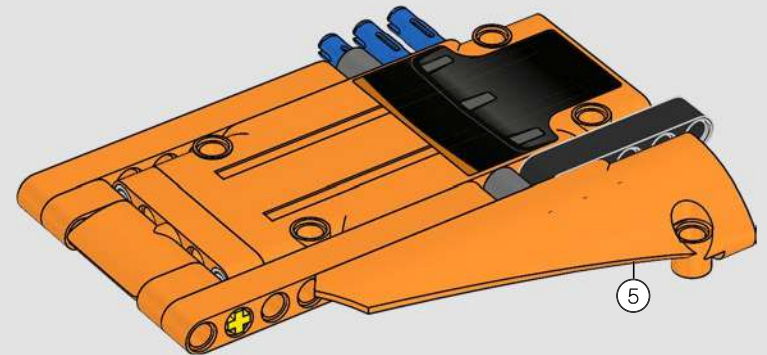

342

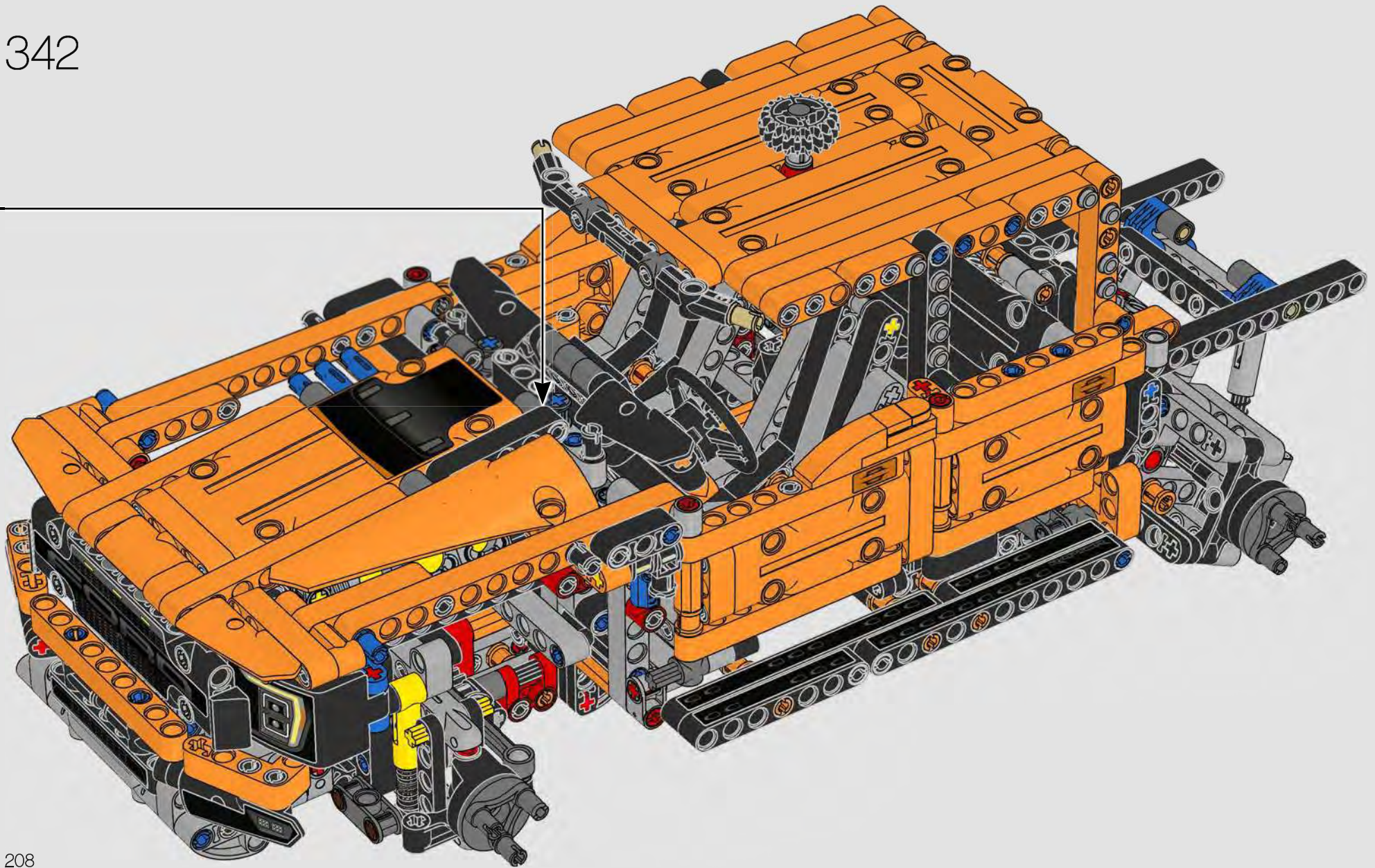



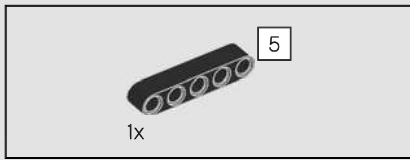

343

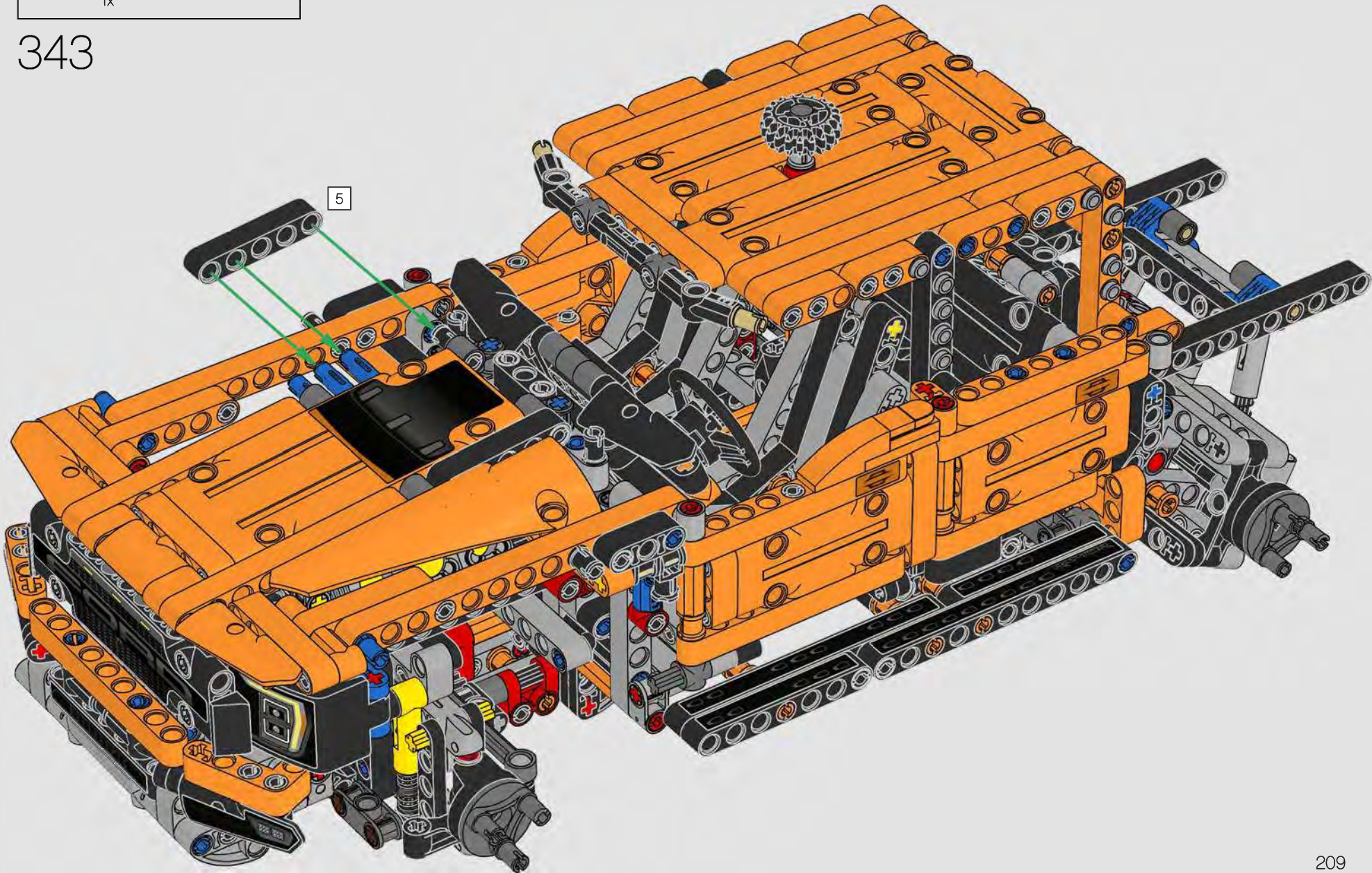

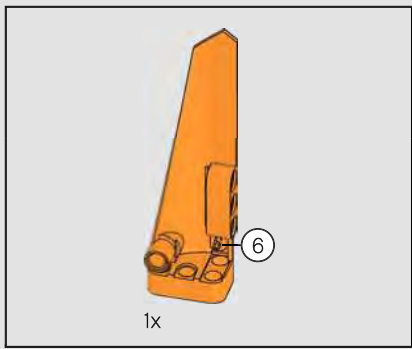

344

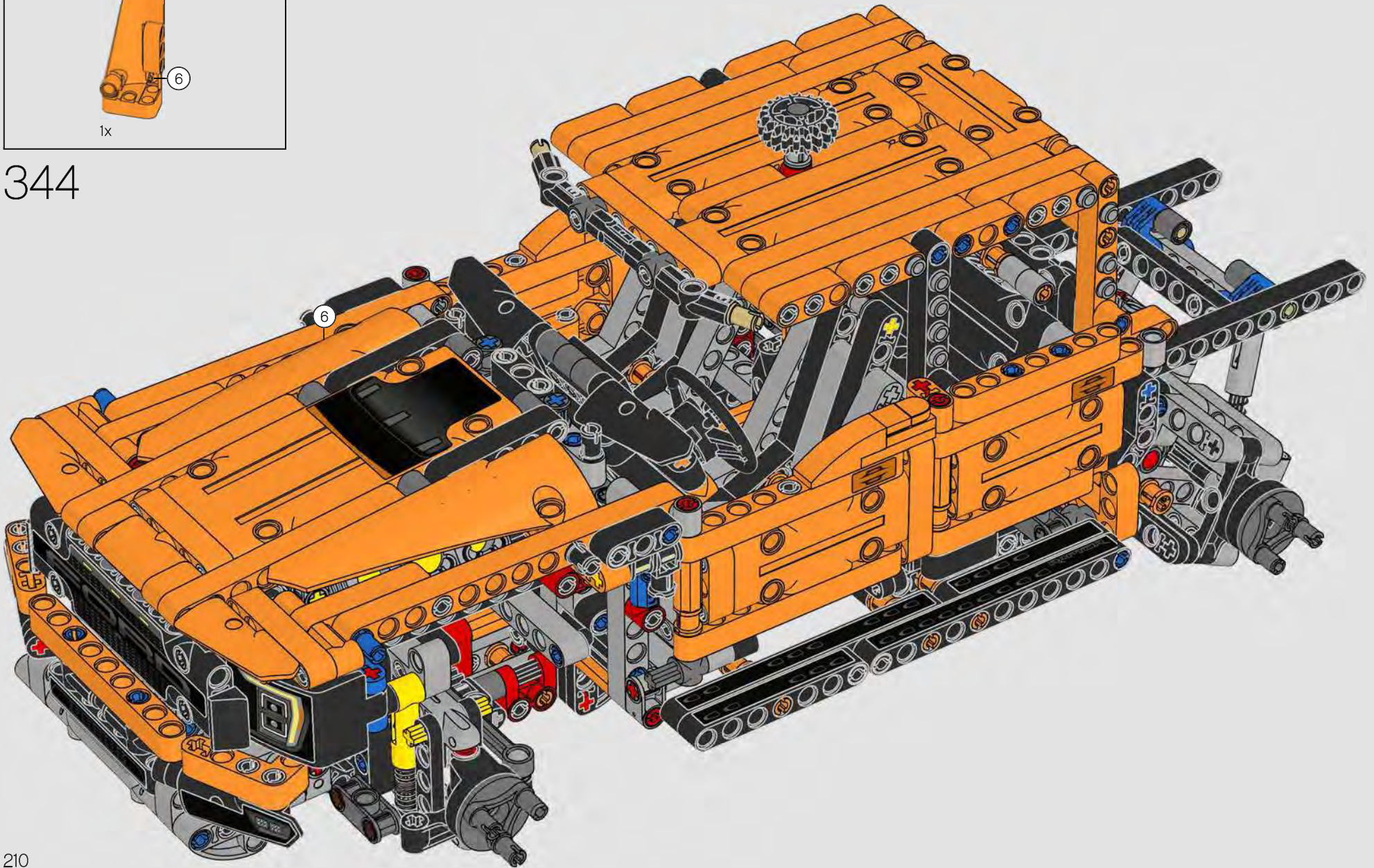

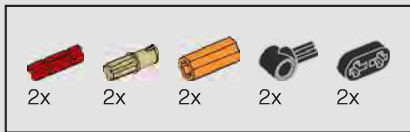

345

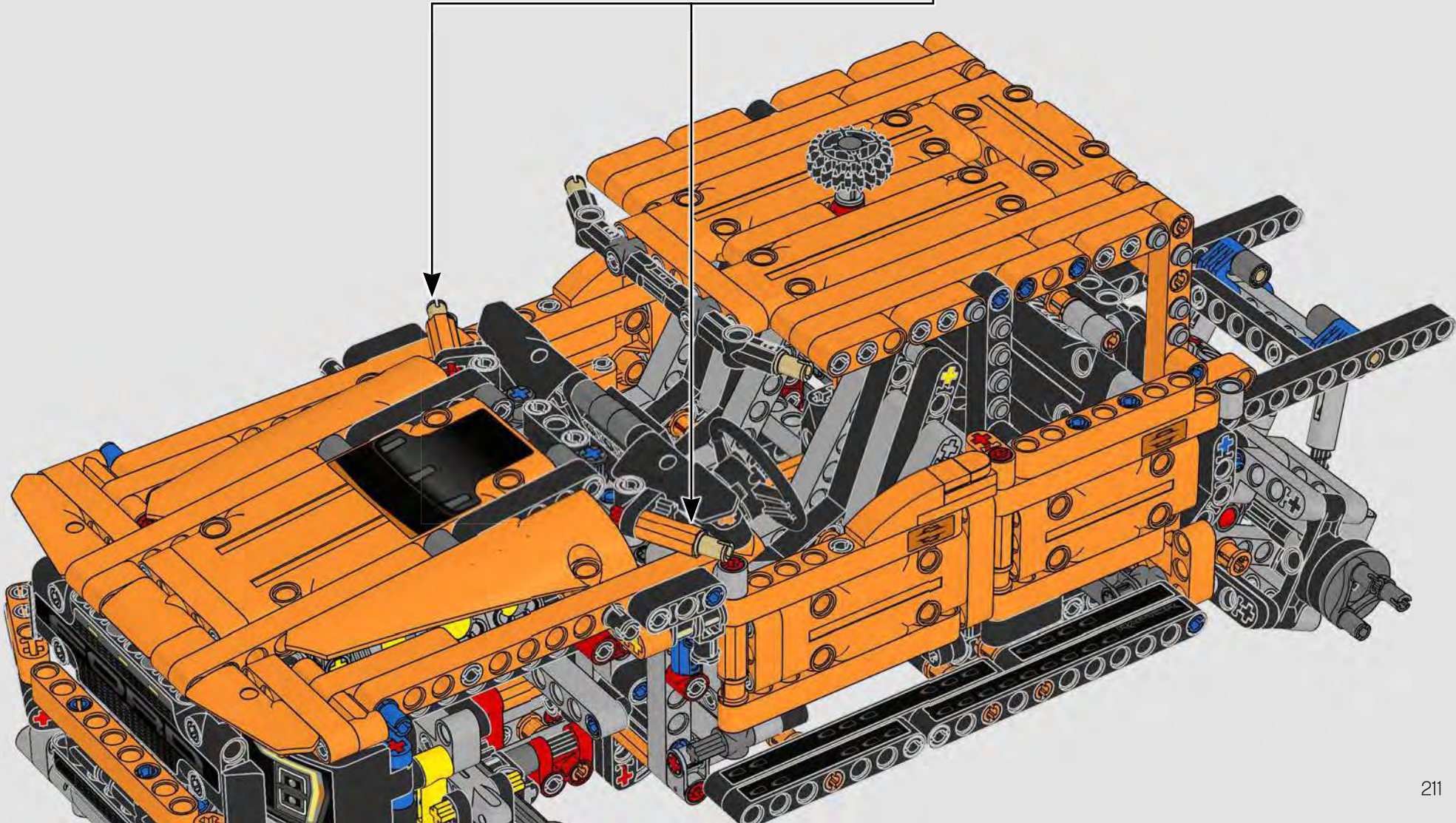
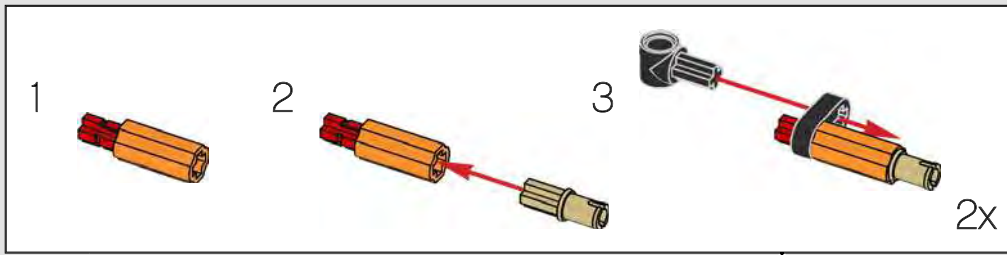

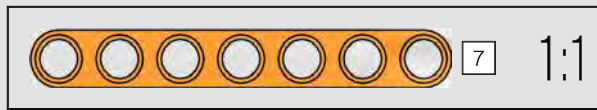
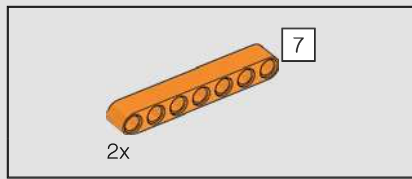

346

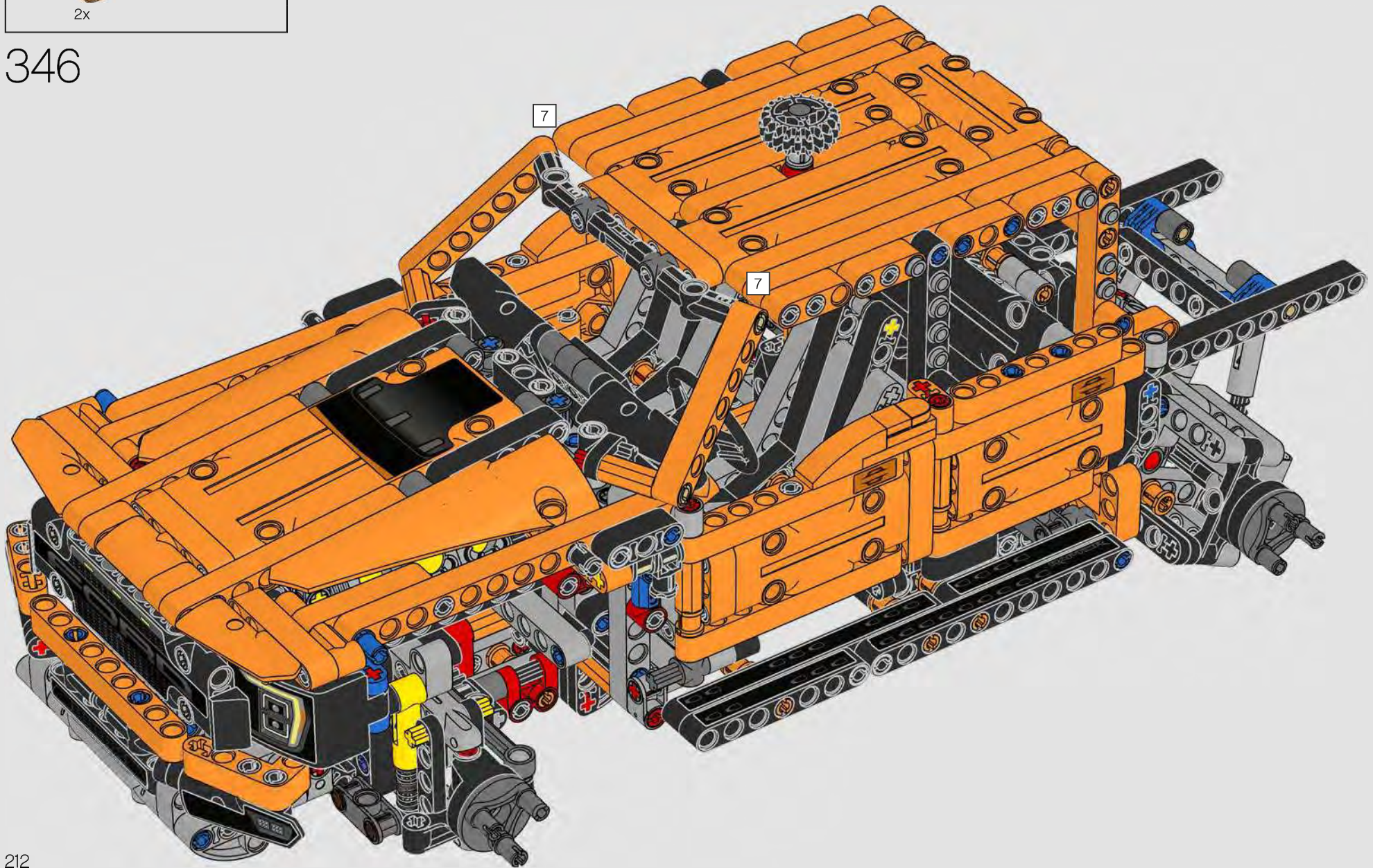

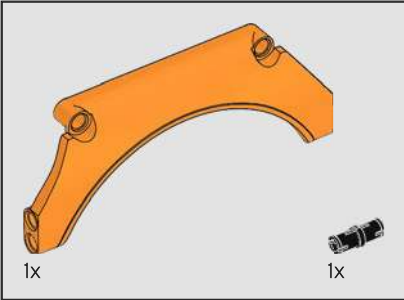
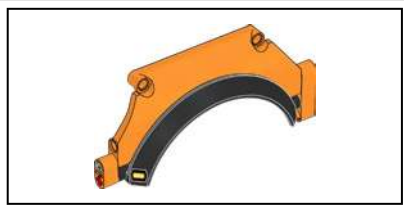

347

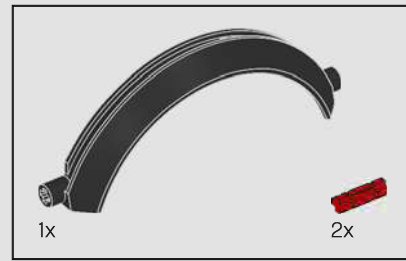
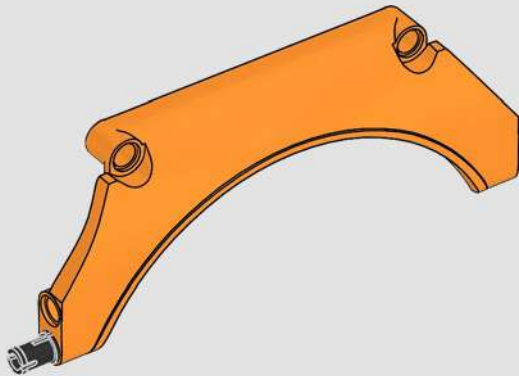

348

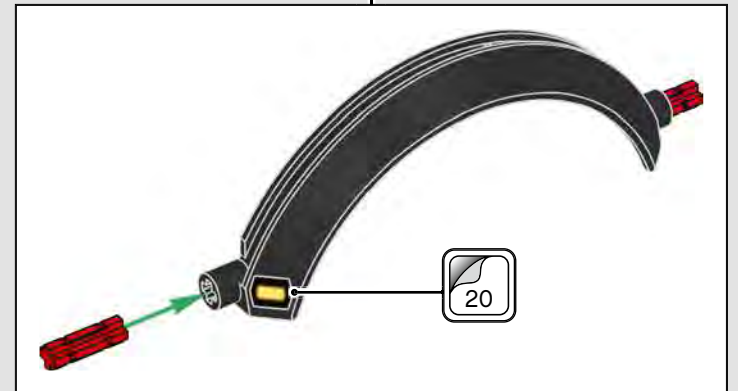
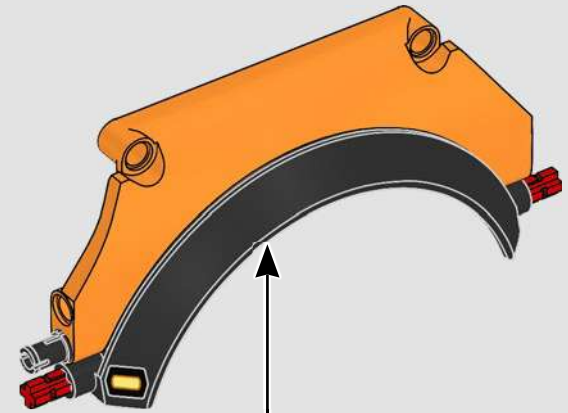



349

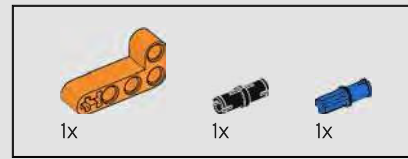
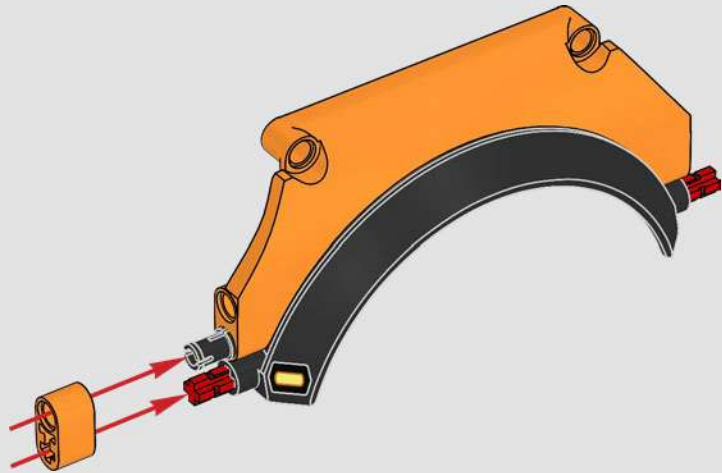

350

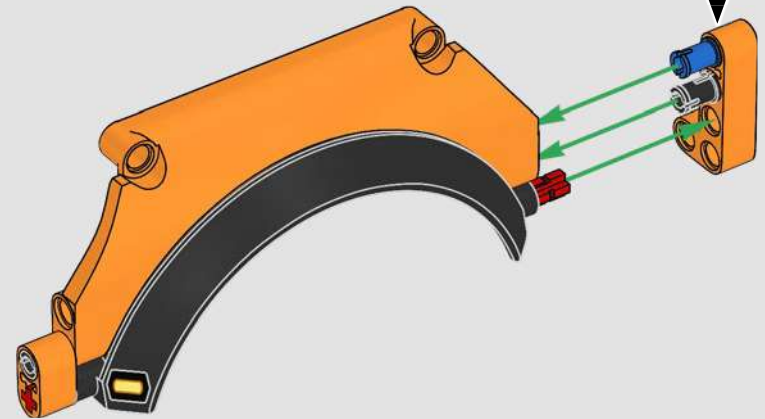
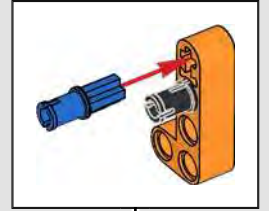

351

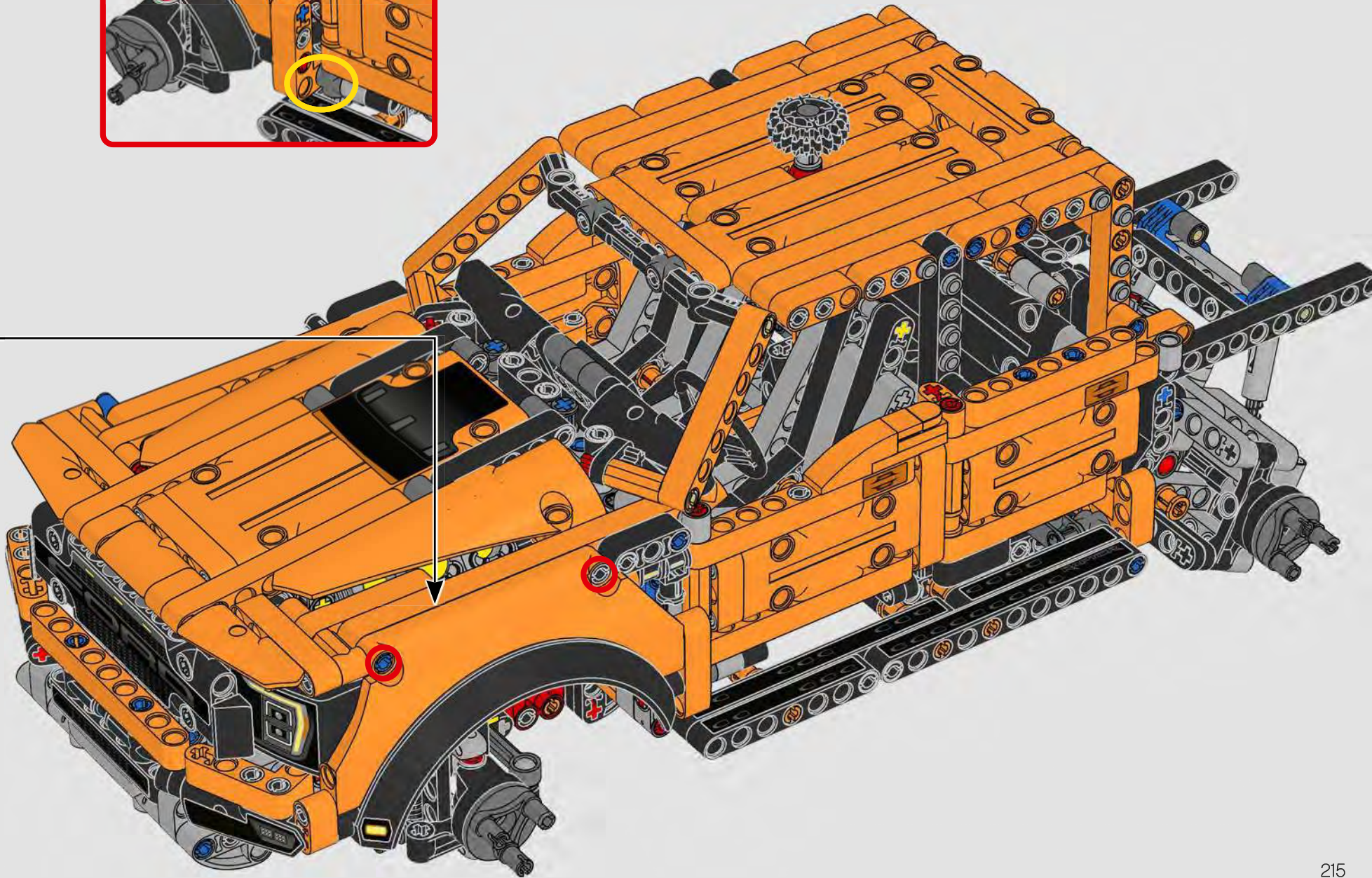
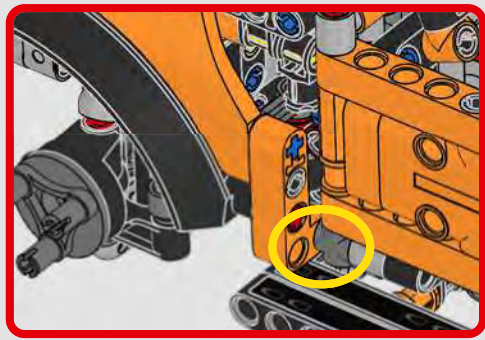

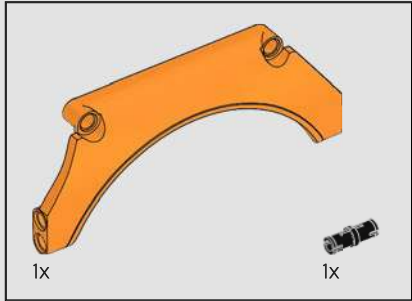
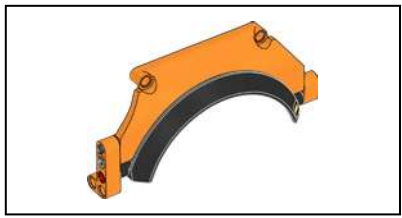

352

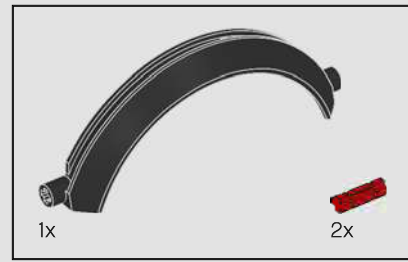
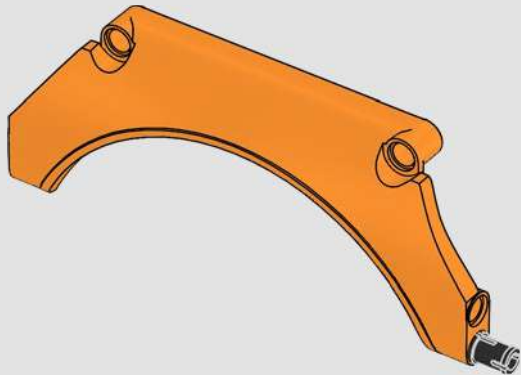

353

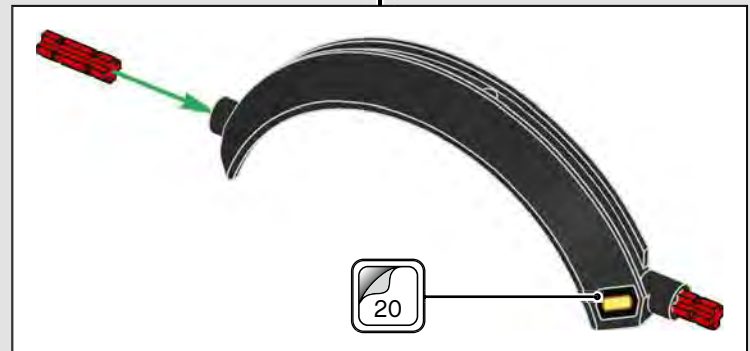
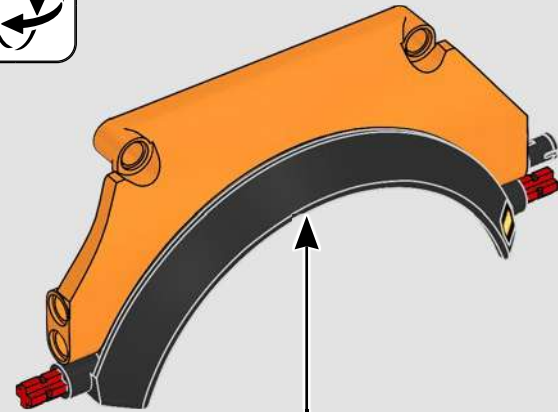
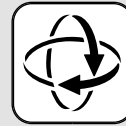





354

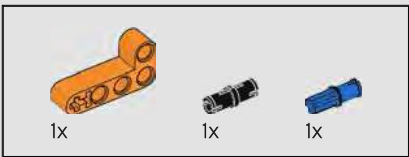
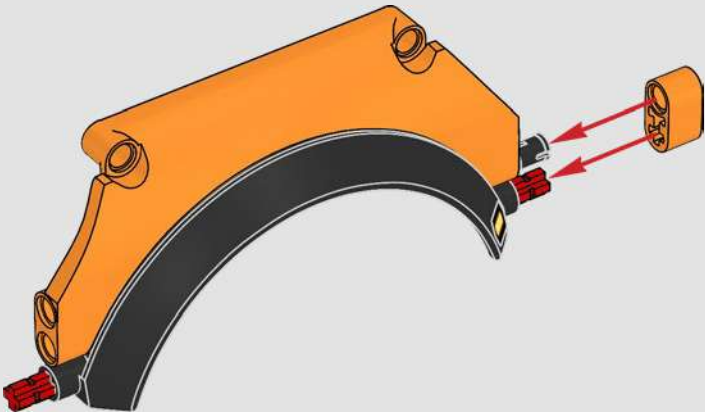

355

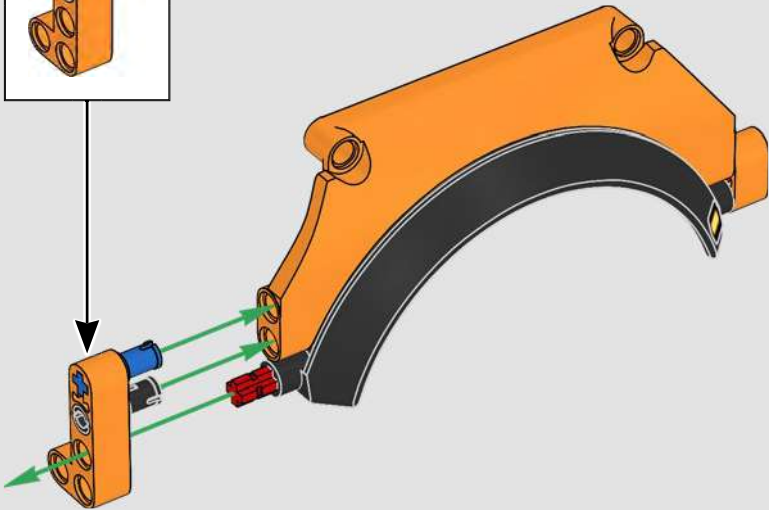

356

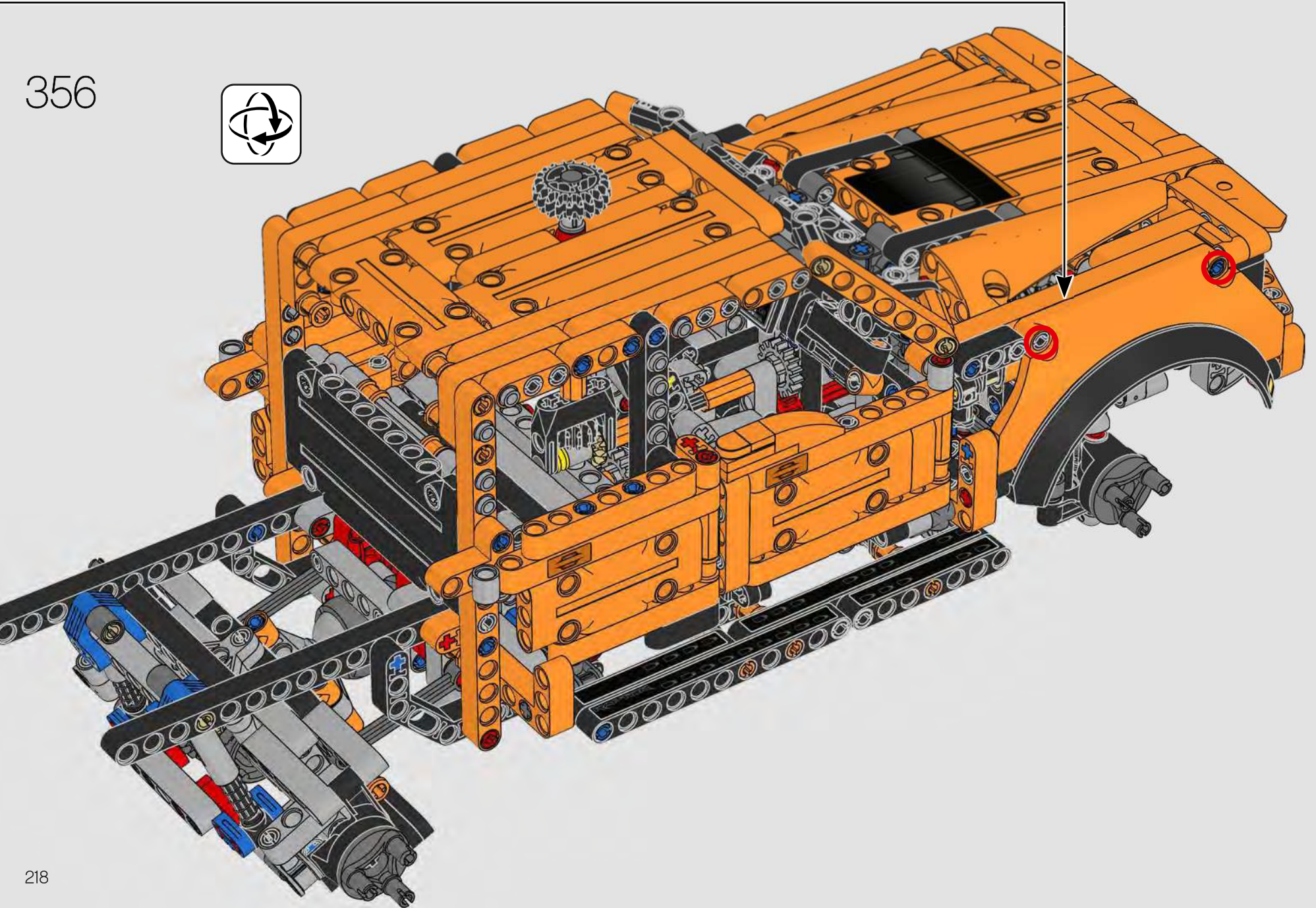



357

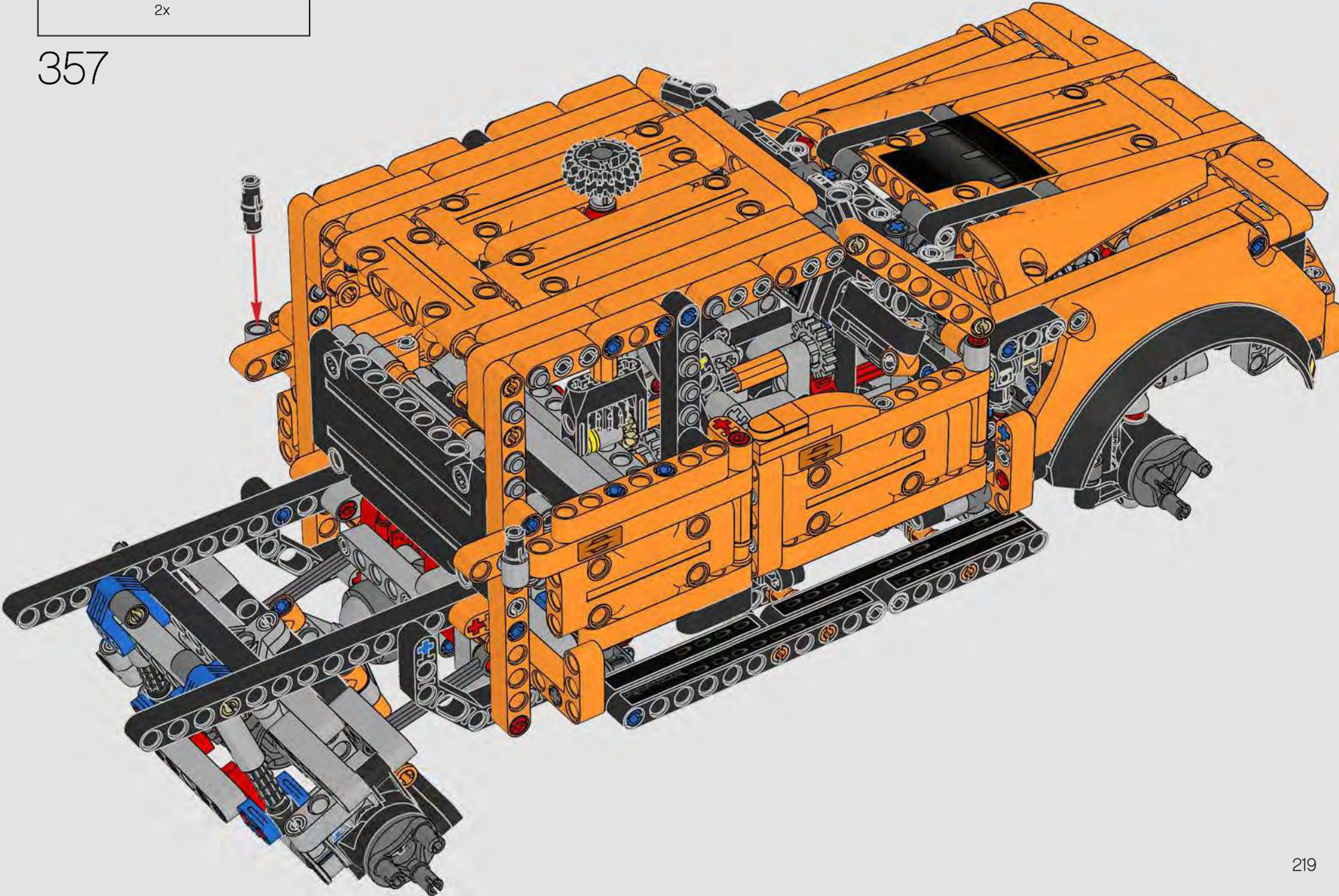

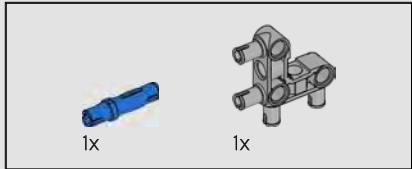
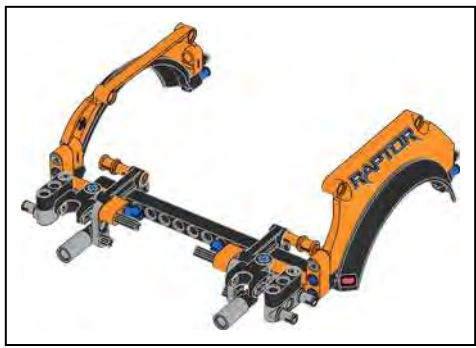

358

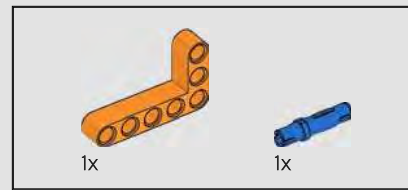
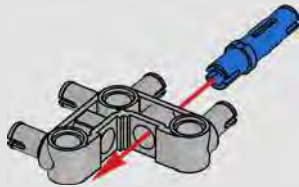

359

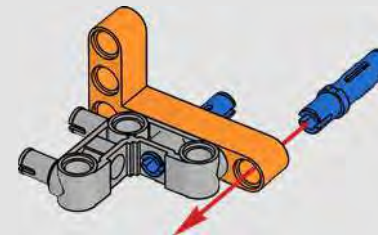

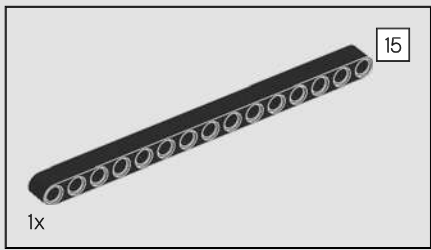

360

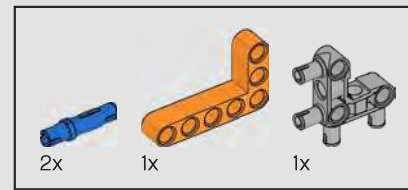
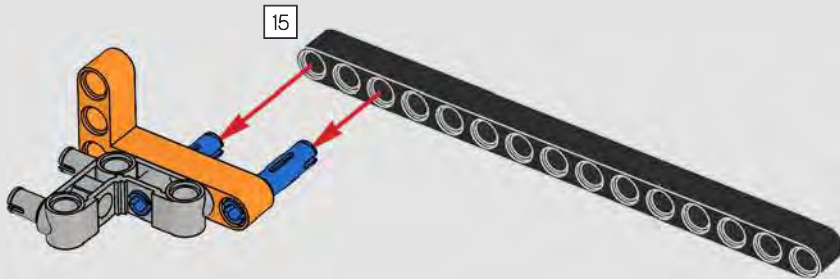

361

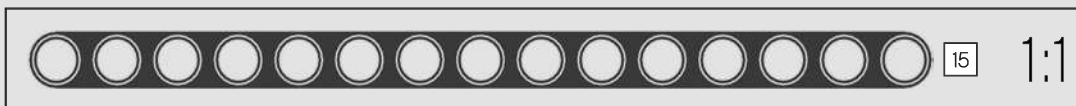
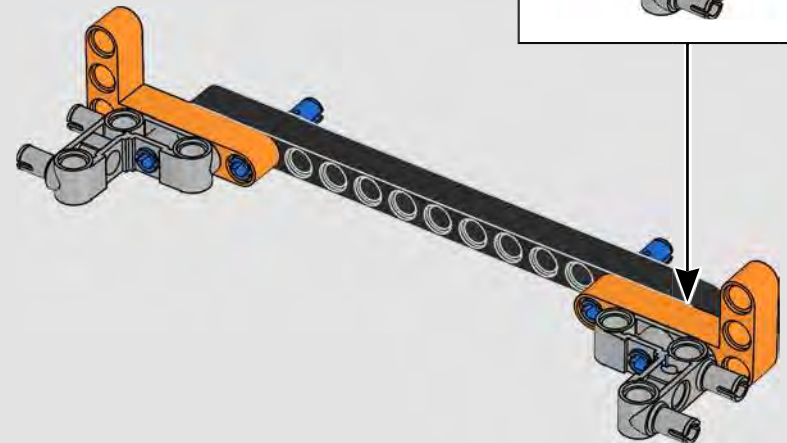
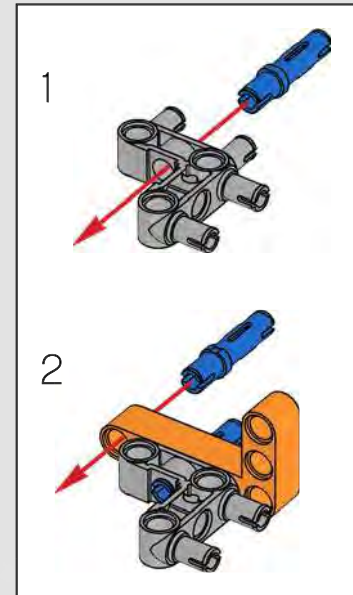

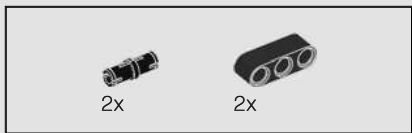

362

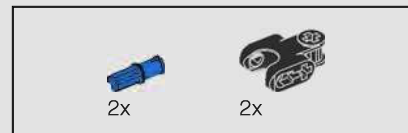
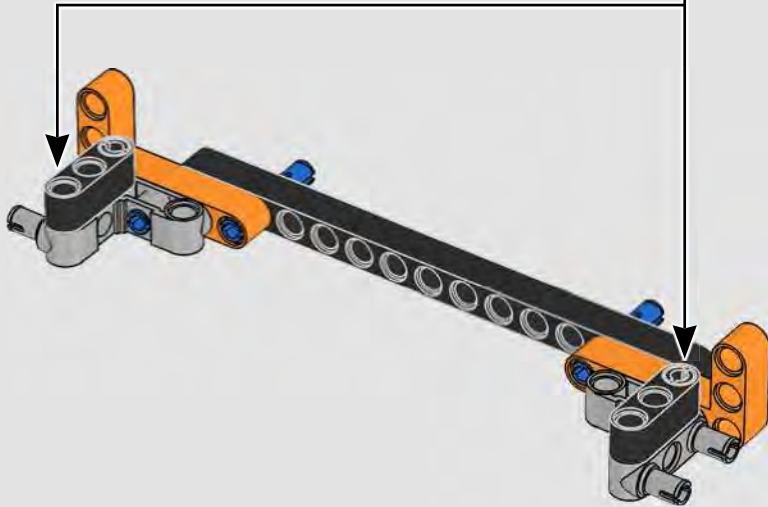
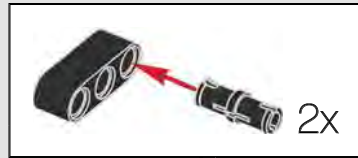

363

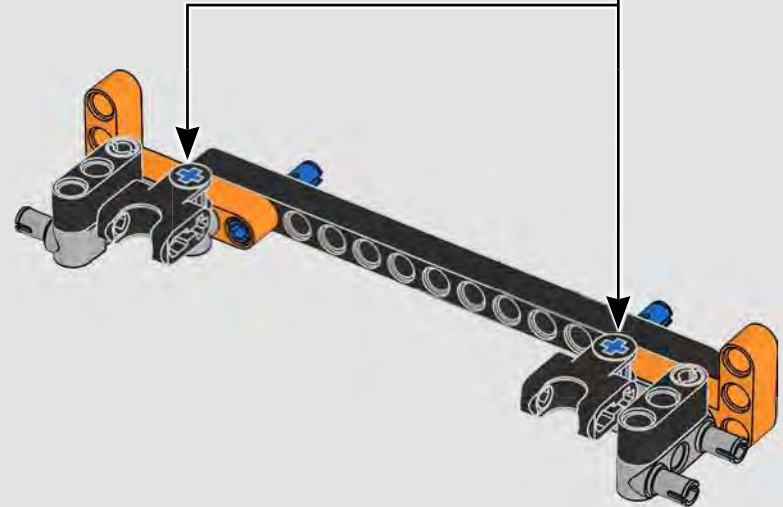
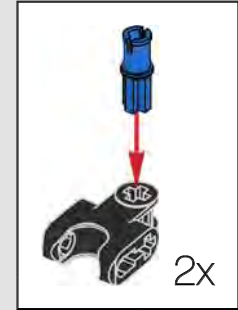

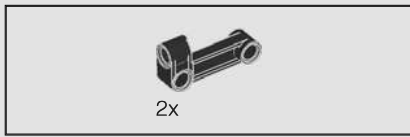

364

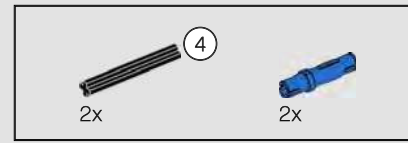
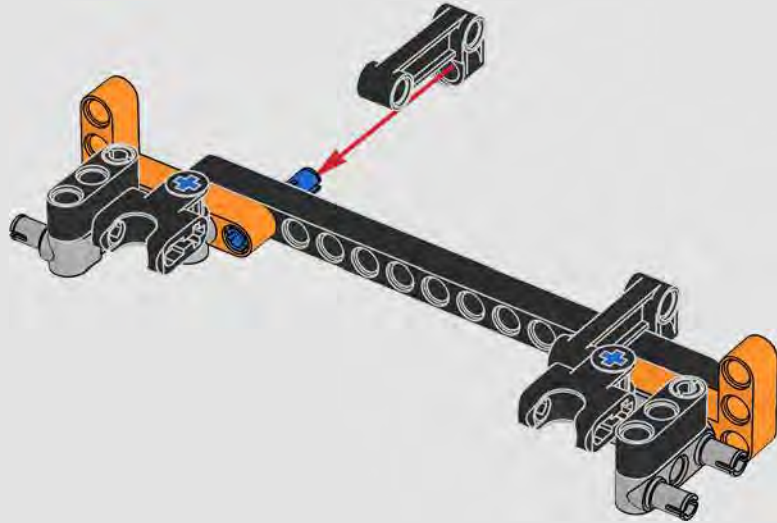

365

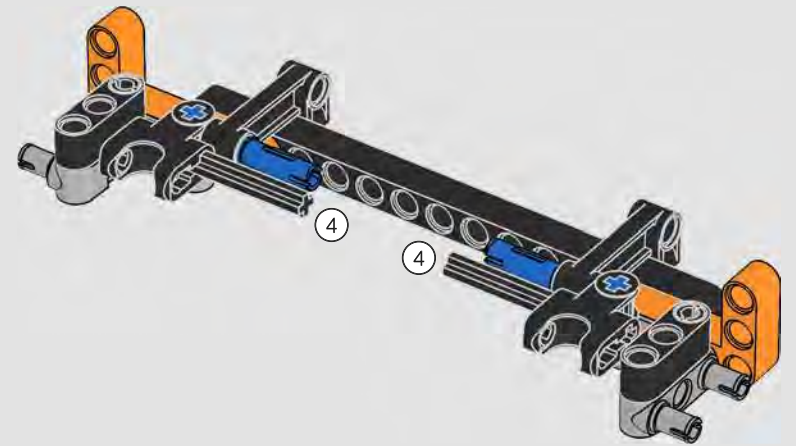
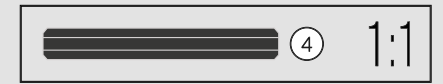

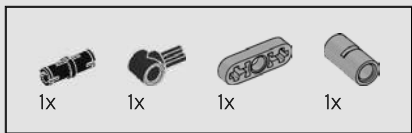

366

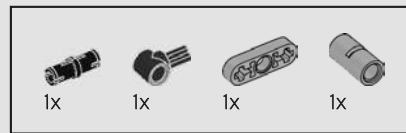
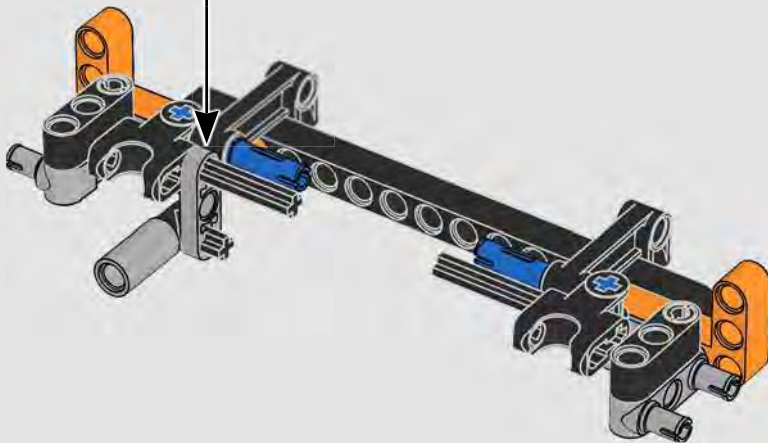
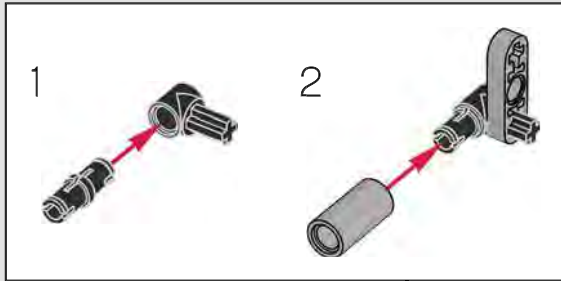

367

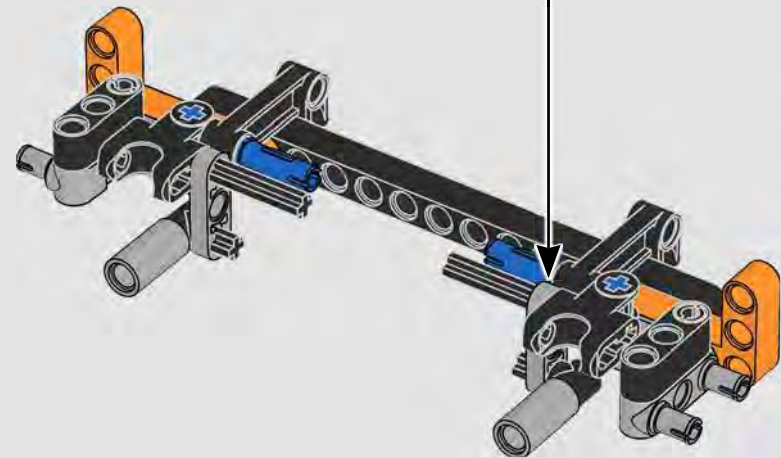
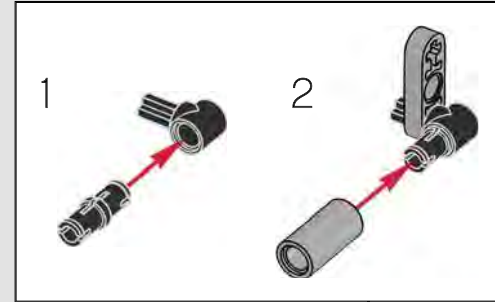





368



369

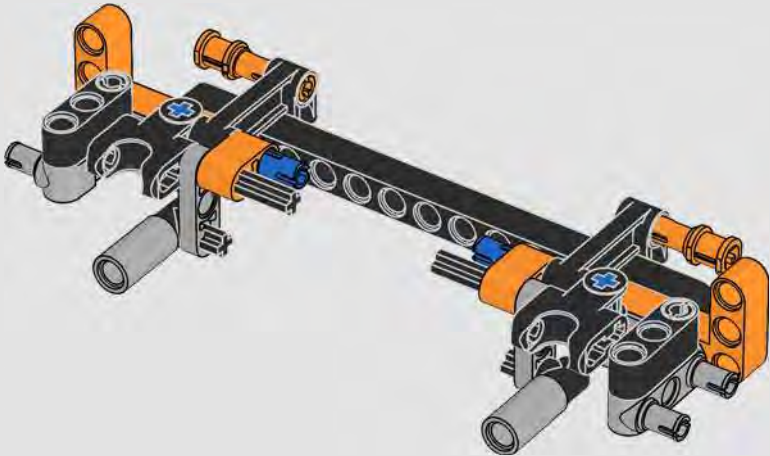
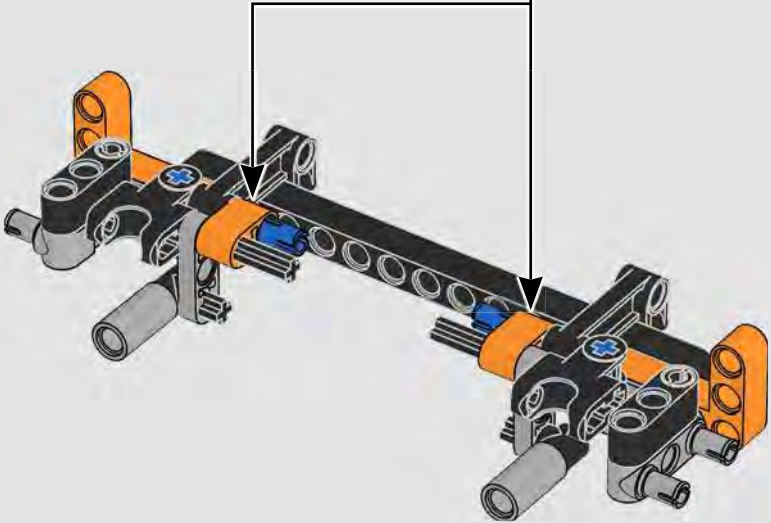
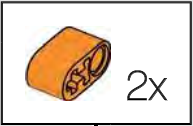

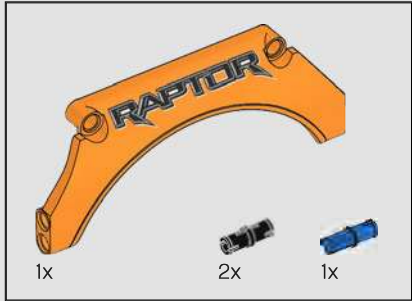

370

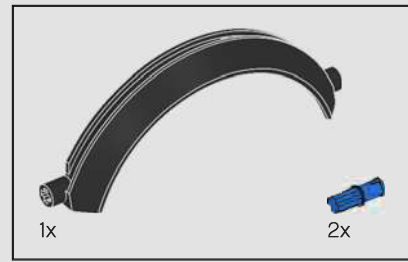

371

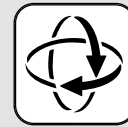

*The first production Raptor came in a molten orange colour with a digital mud graphic.*

372

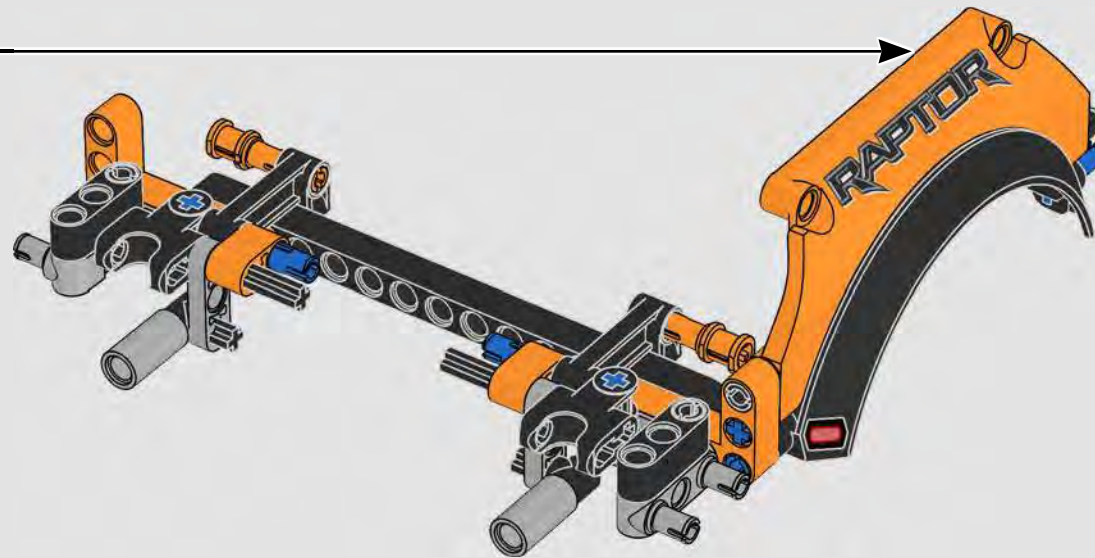

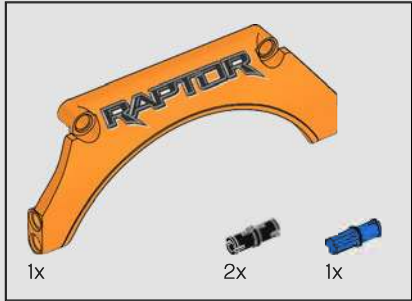

373

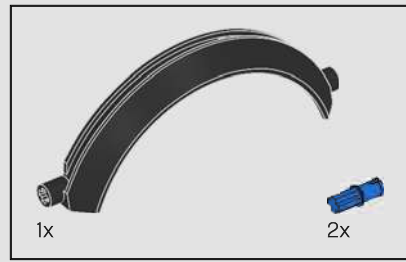

374

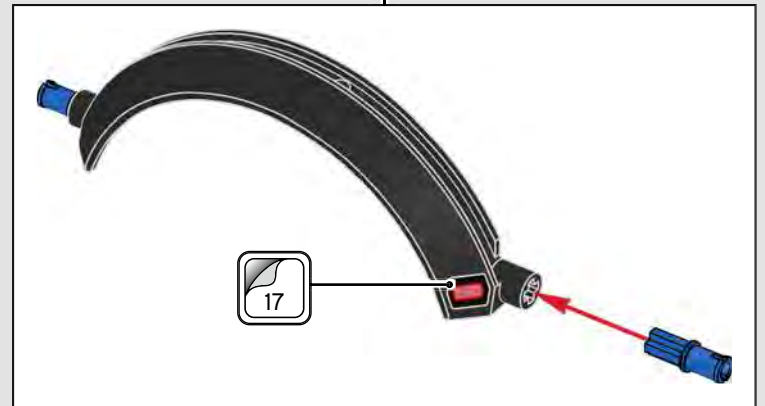

375

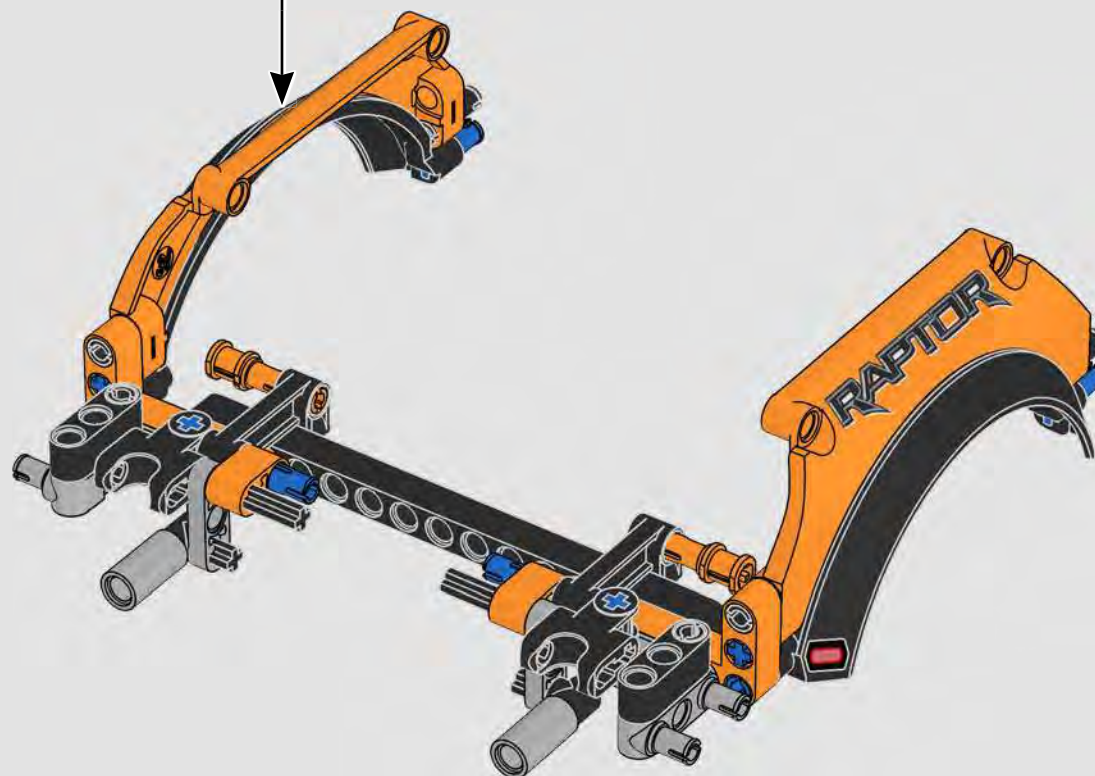

376

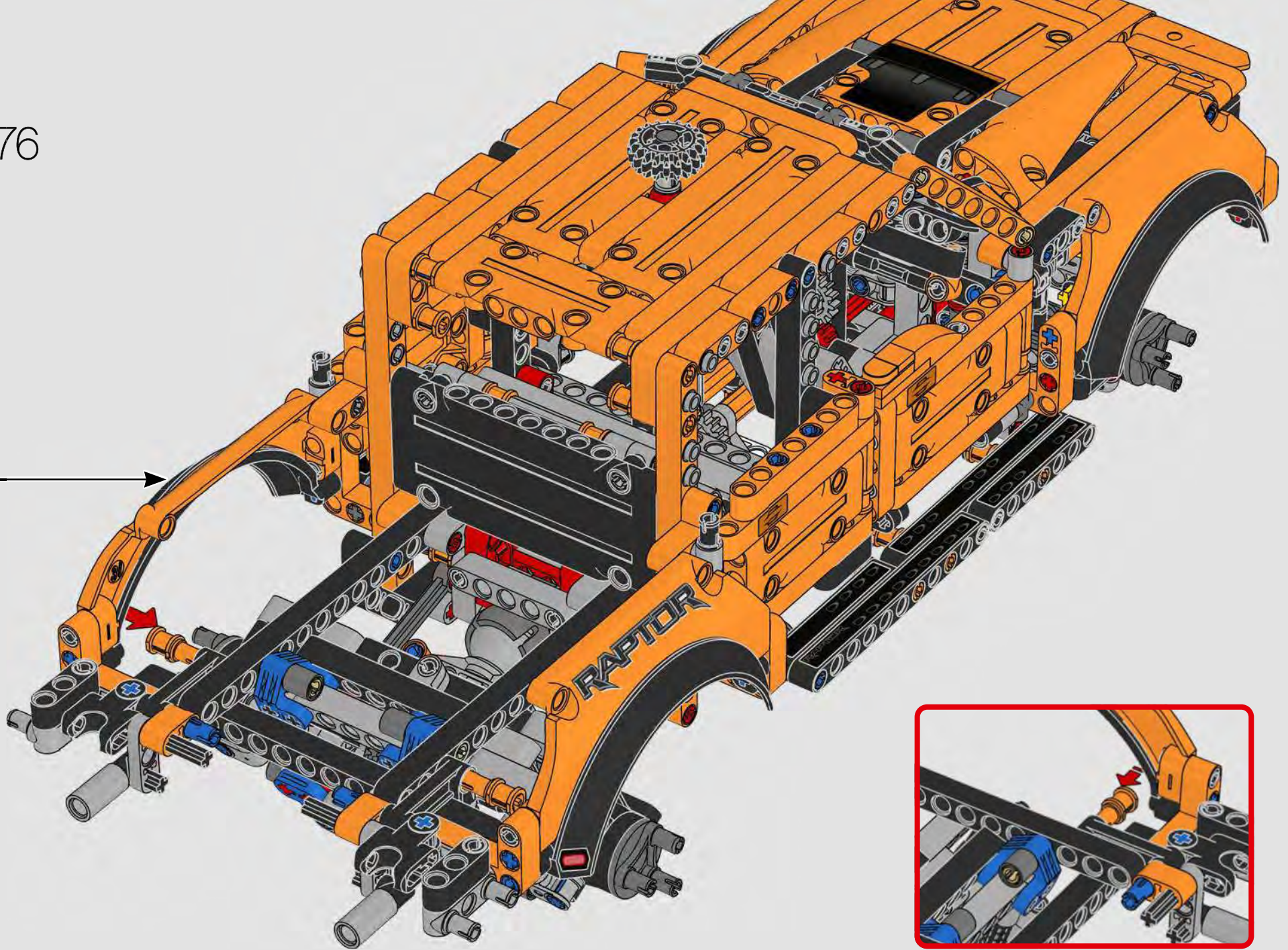

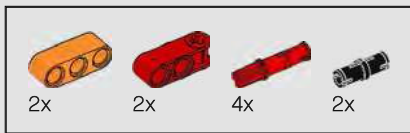

377

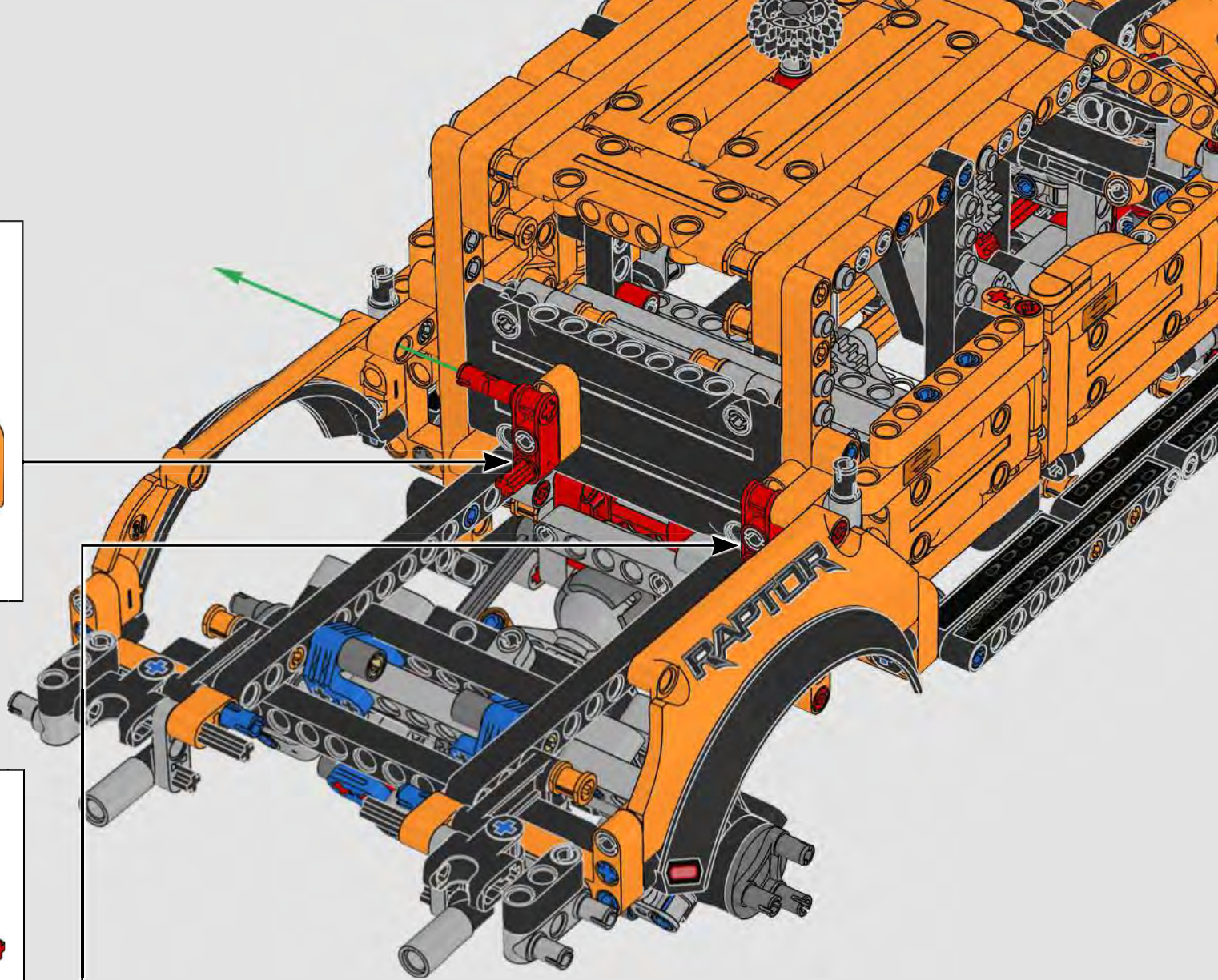
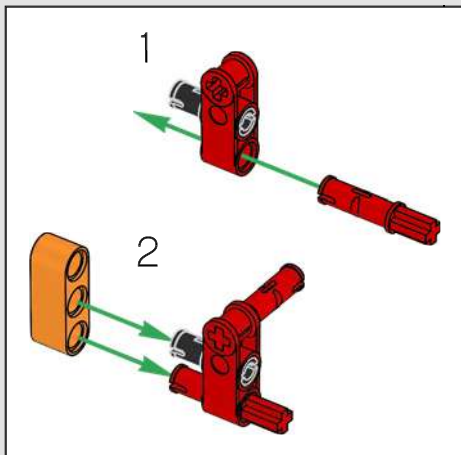
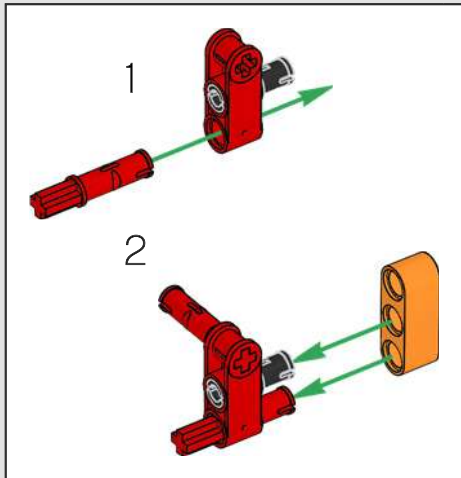

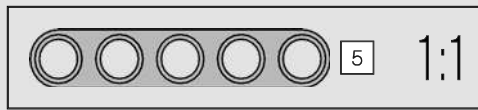
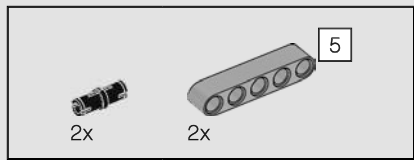

378

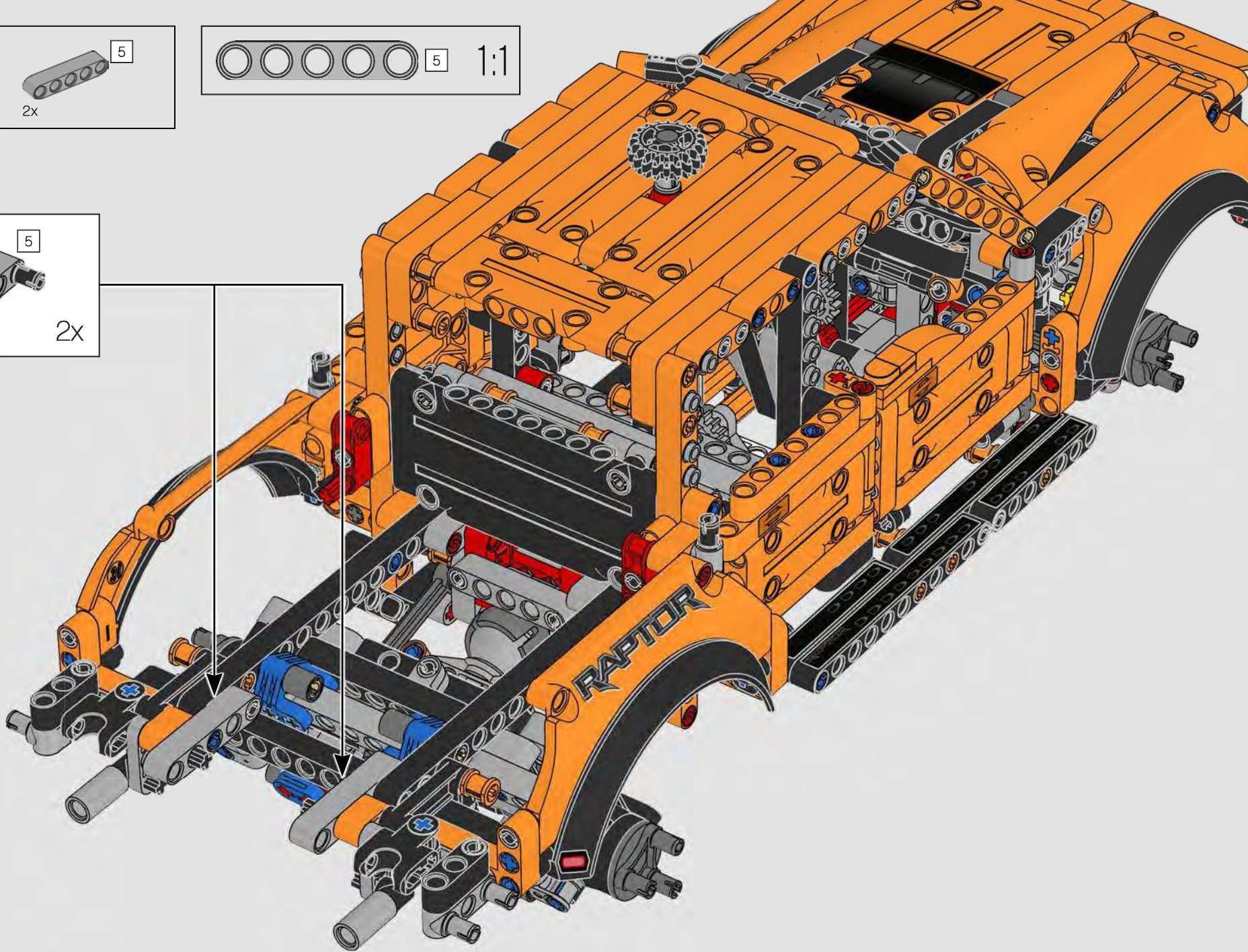
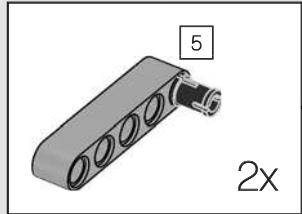



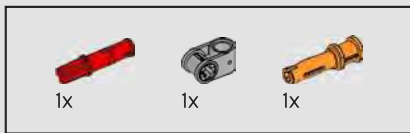

379

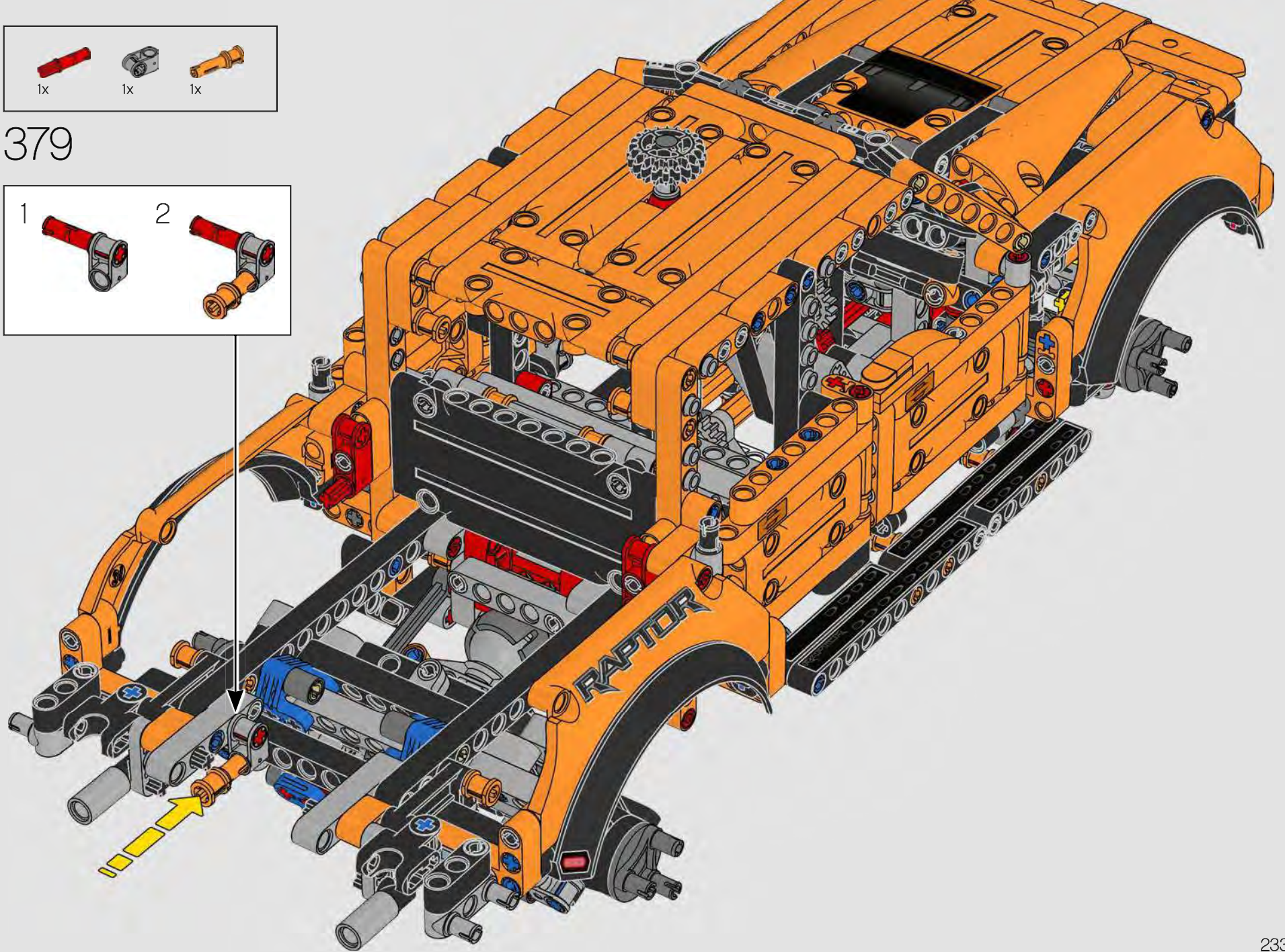
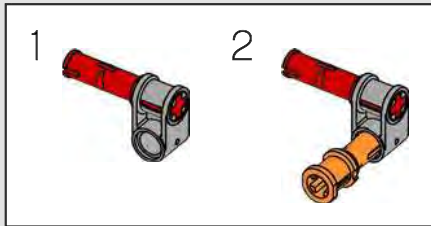

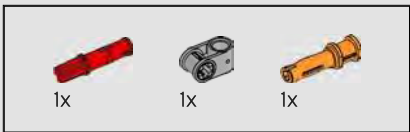

380

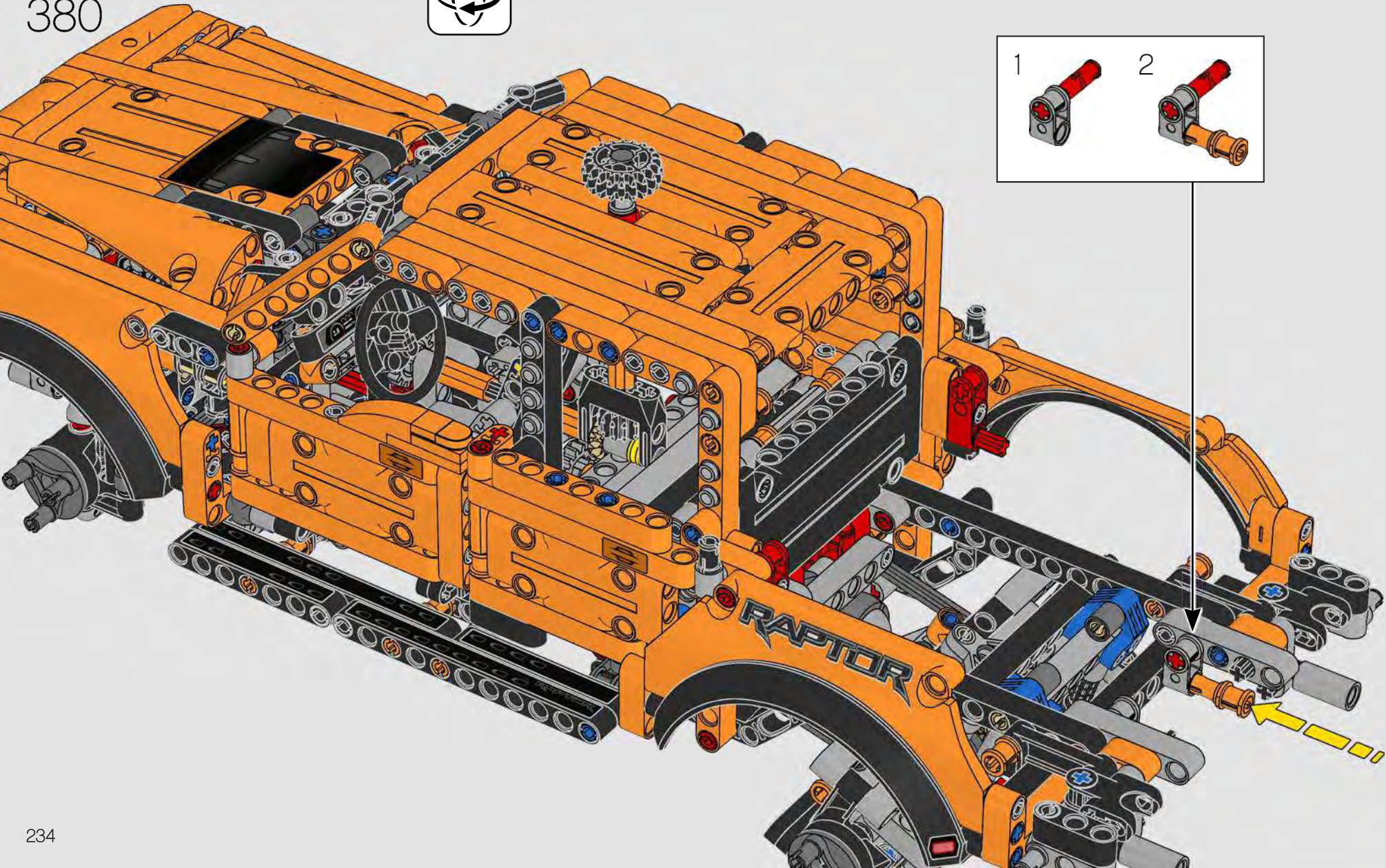
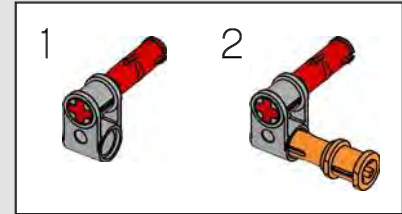

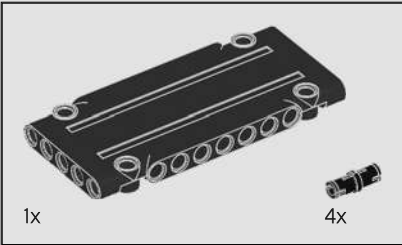
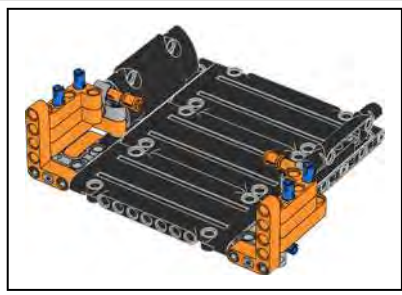

381

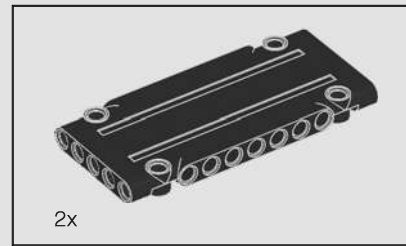
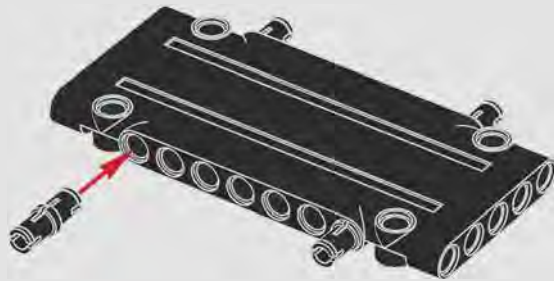

2x

382

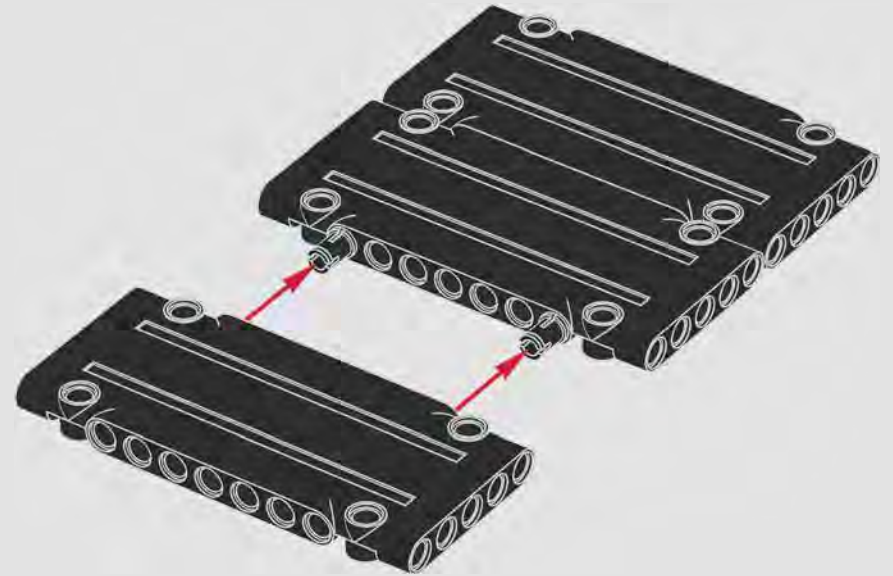



383

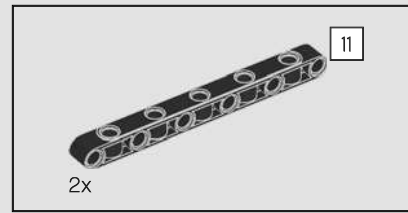
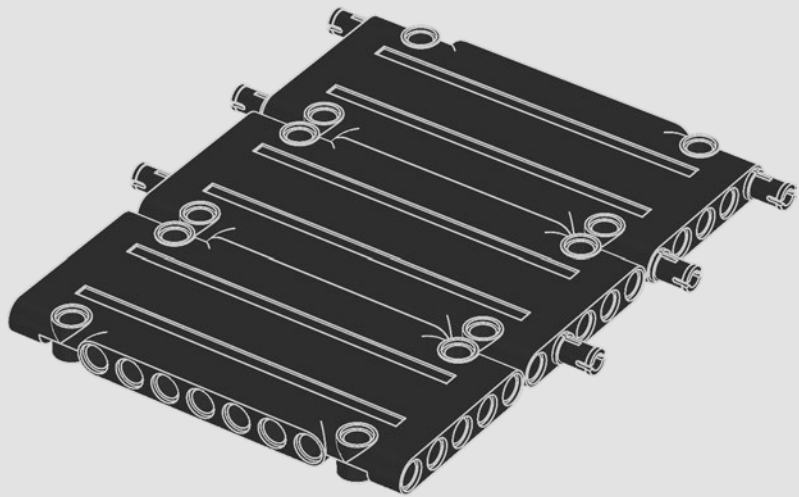

384

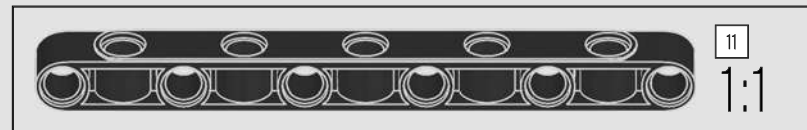
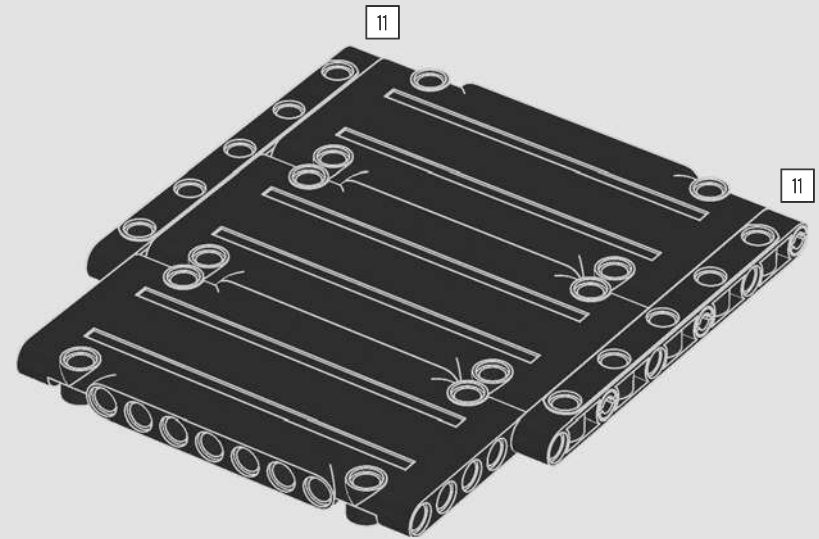

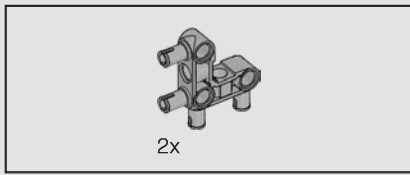

385

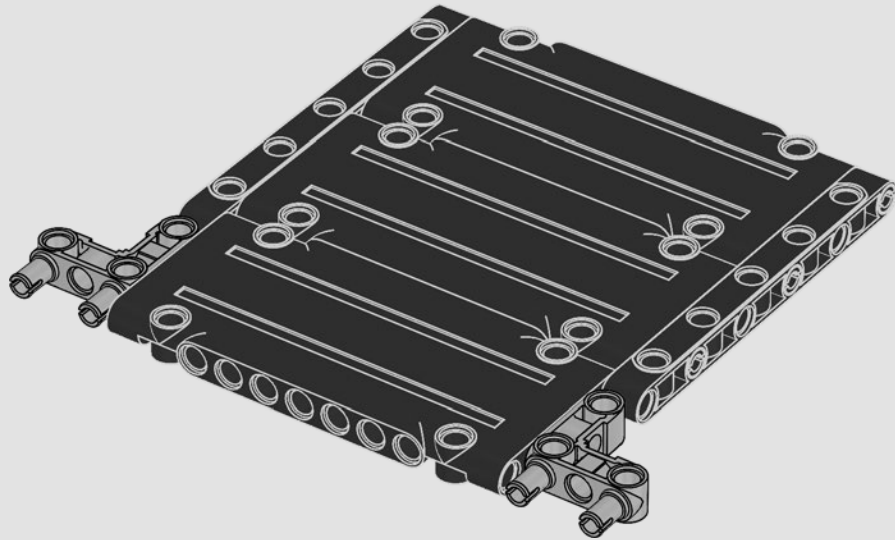

386

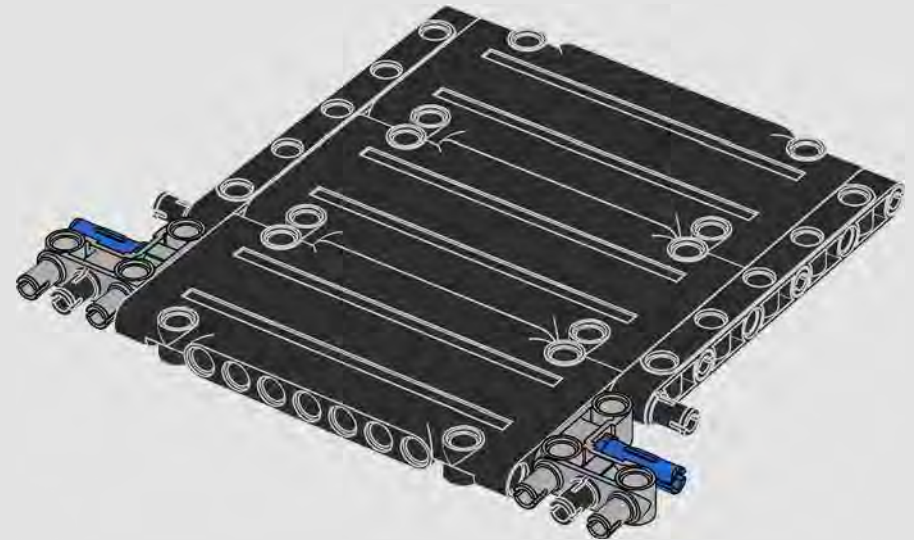



387

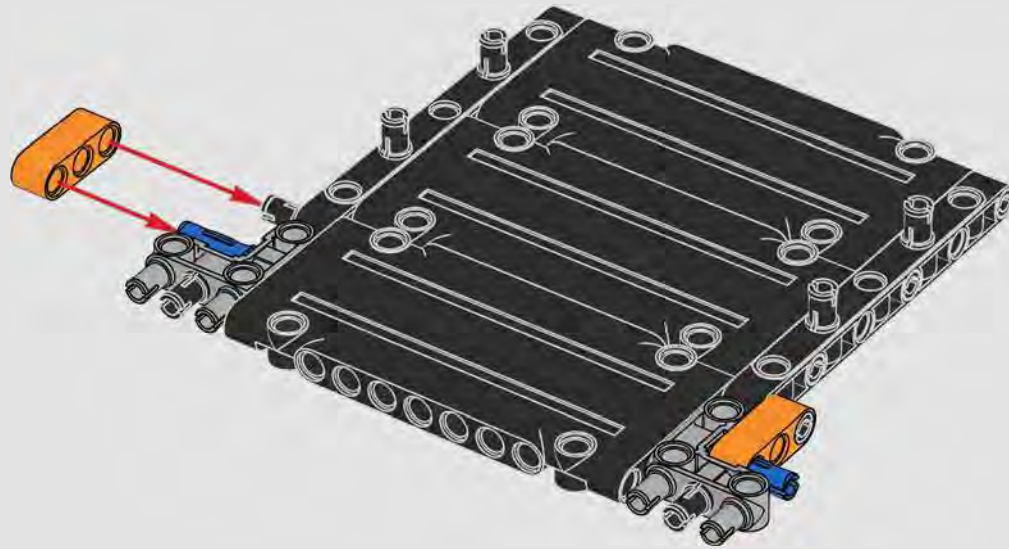



388

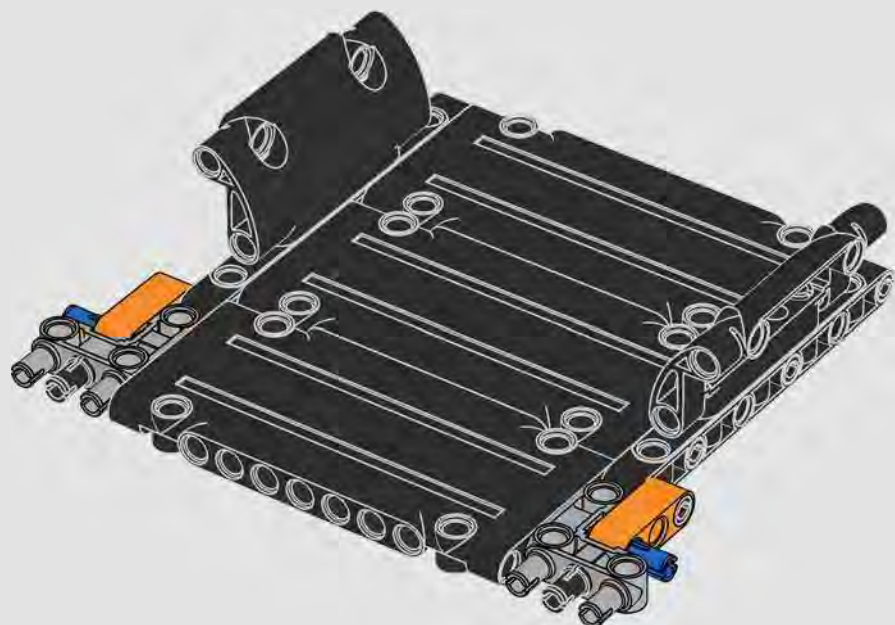

389

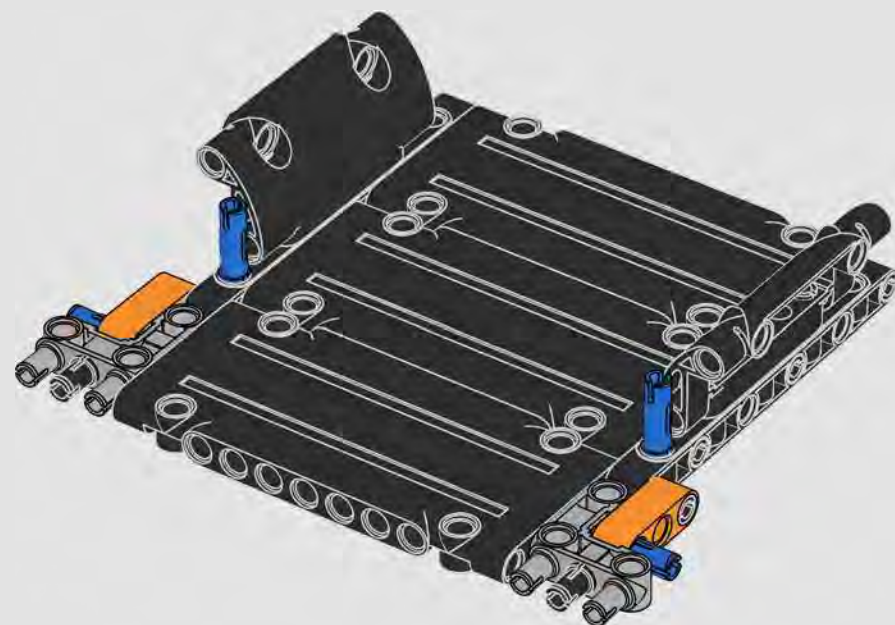

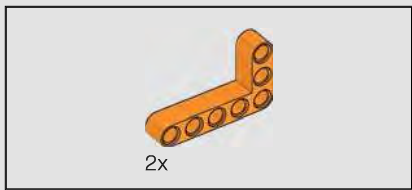

390

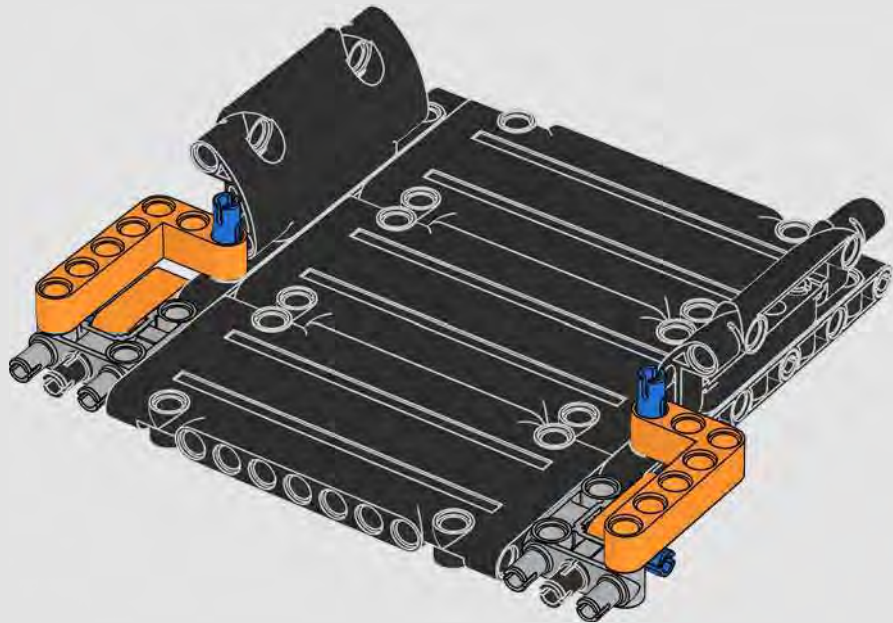

391

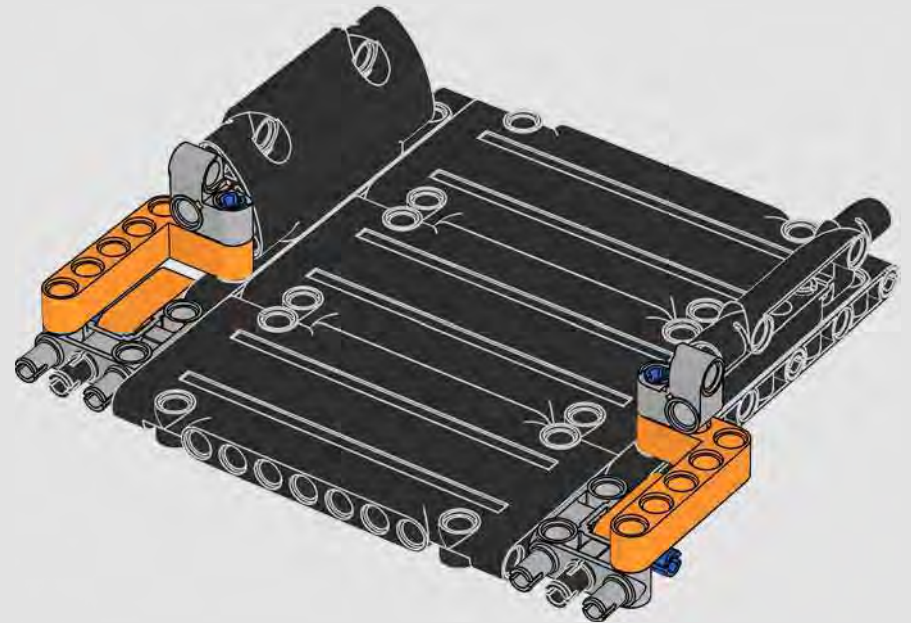



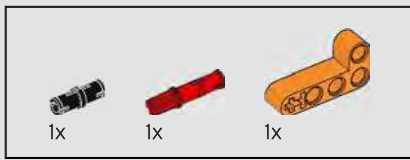

392

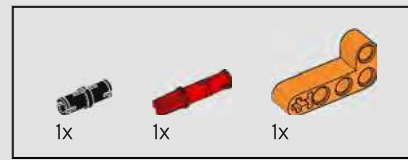
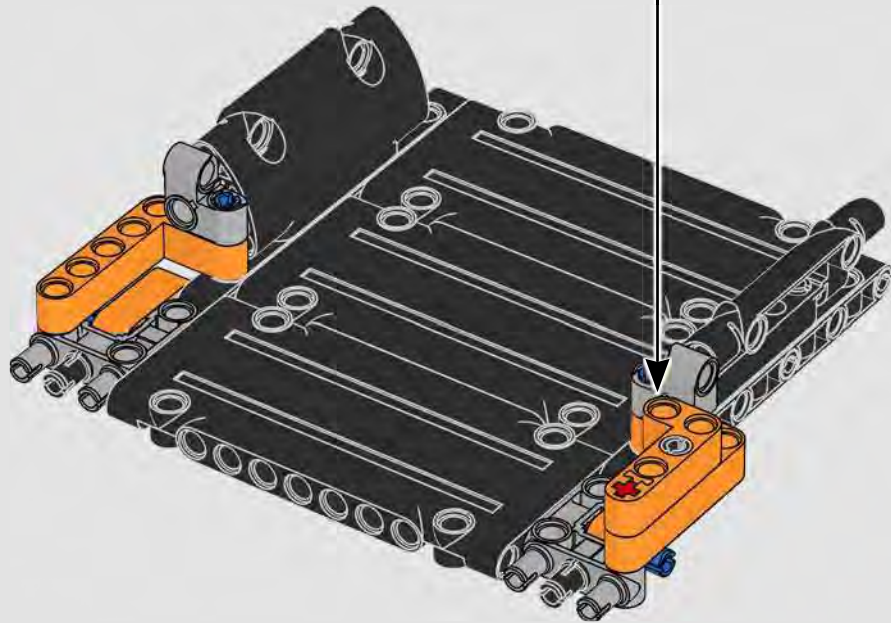
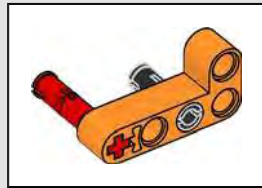

393

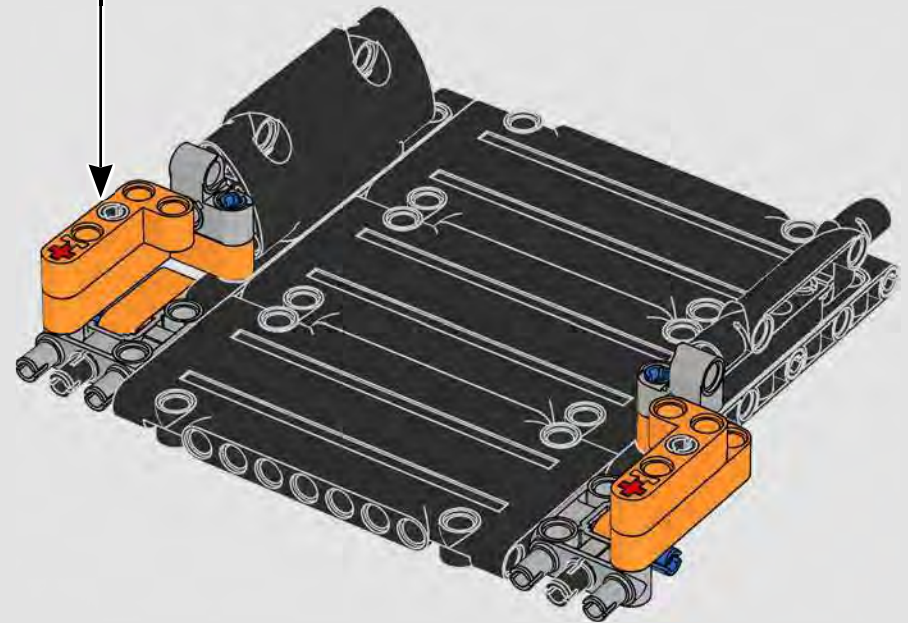
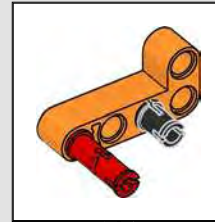



394

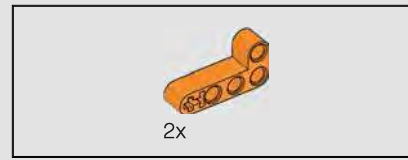
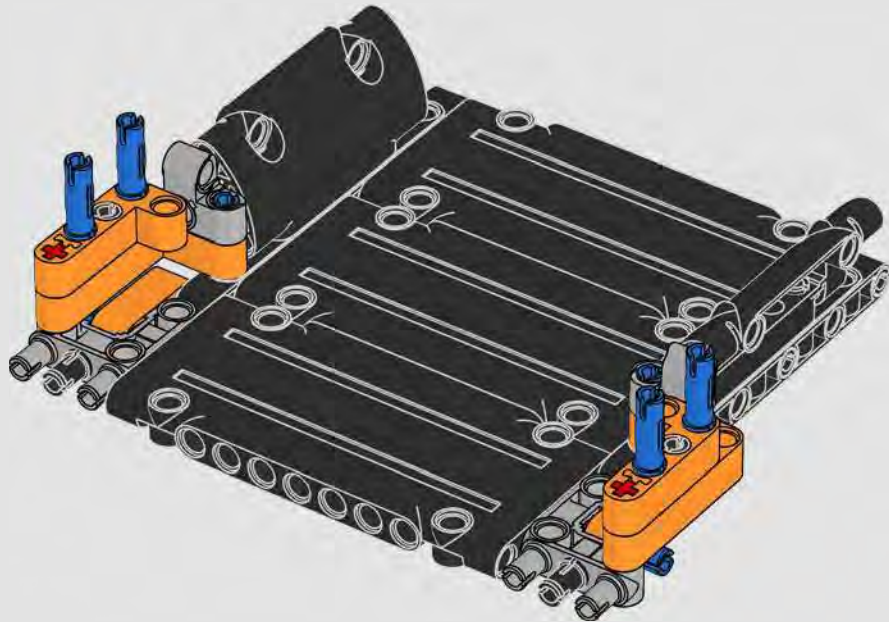

395

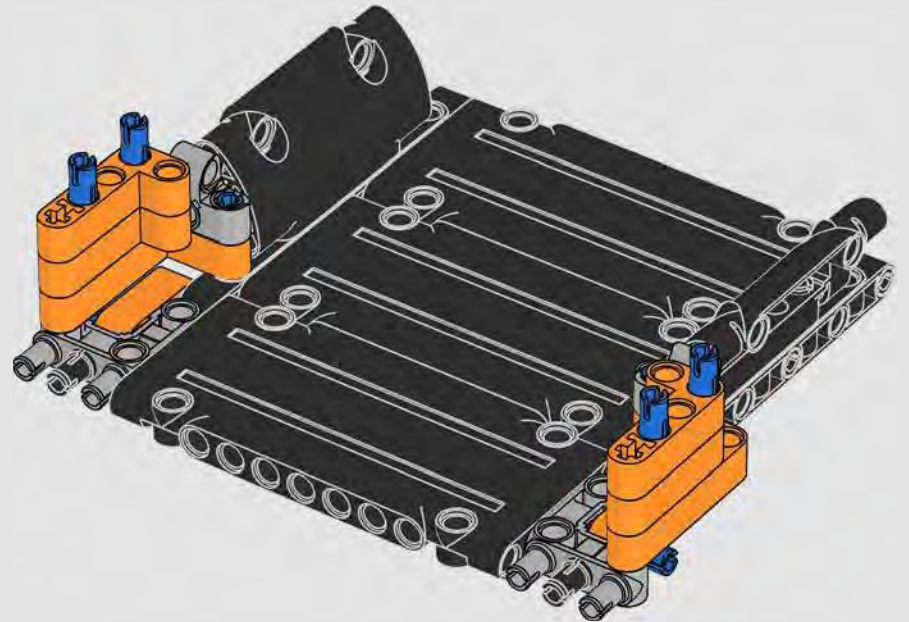

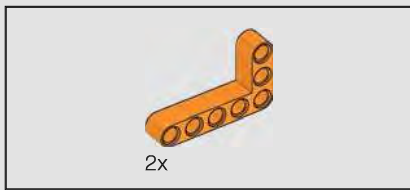

396

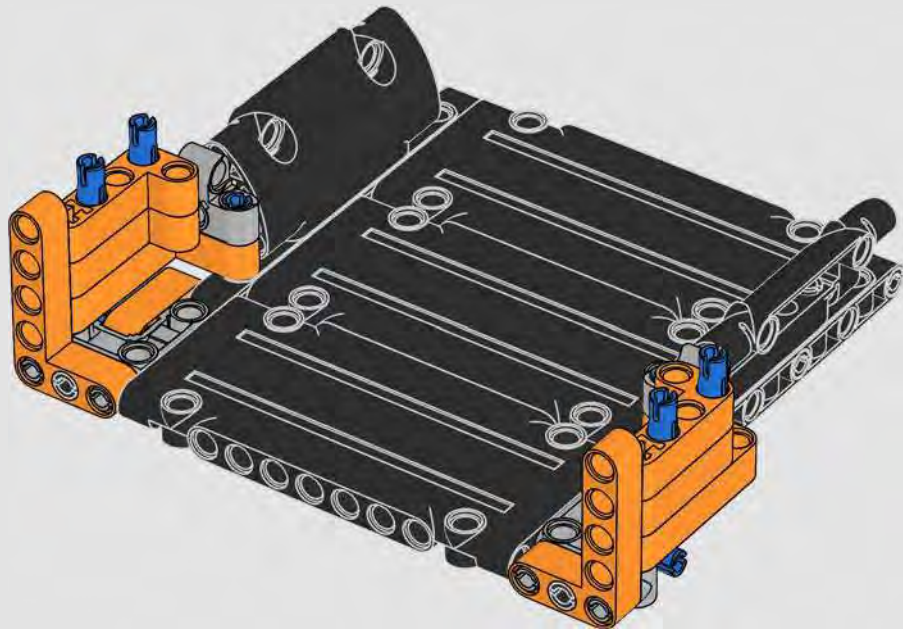

397

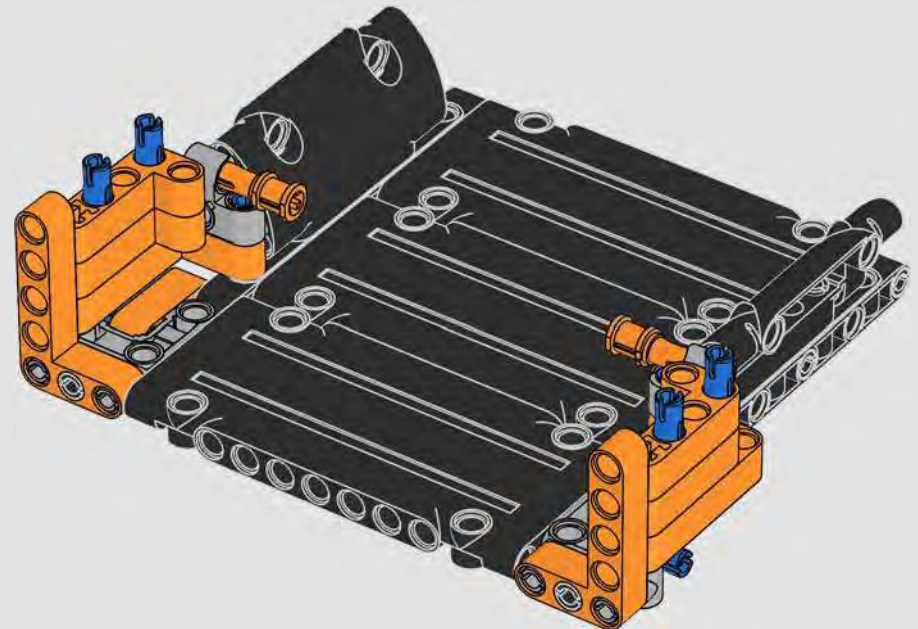

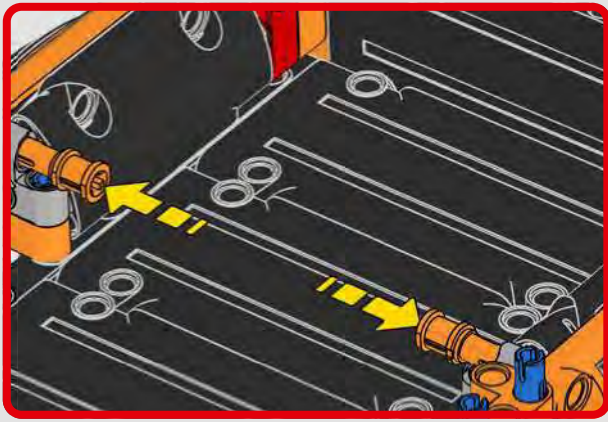

398

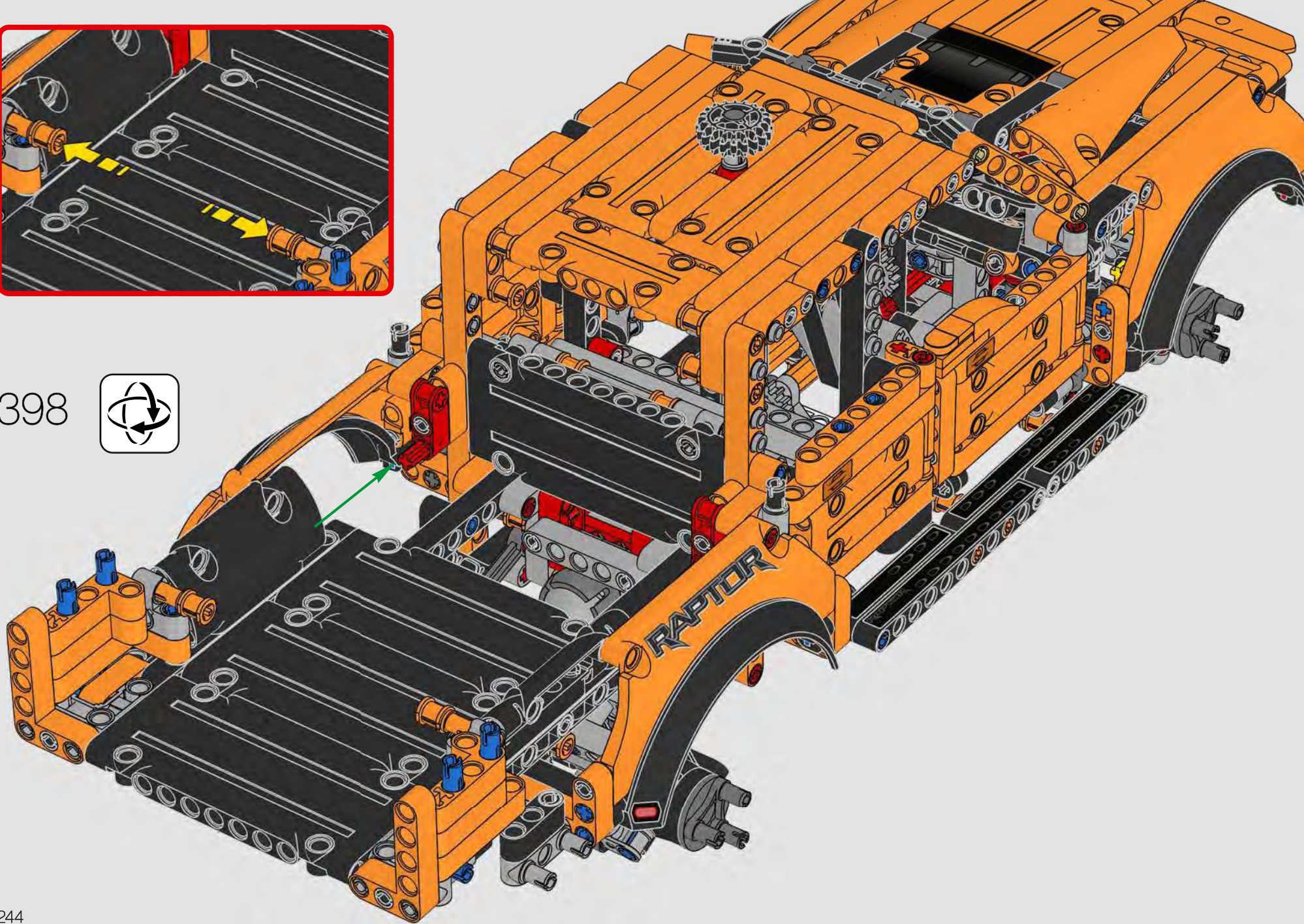



399

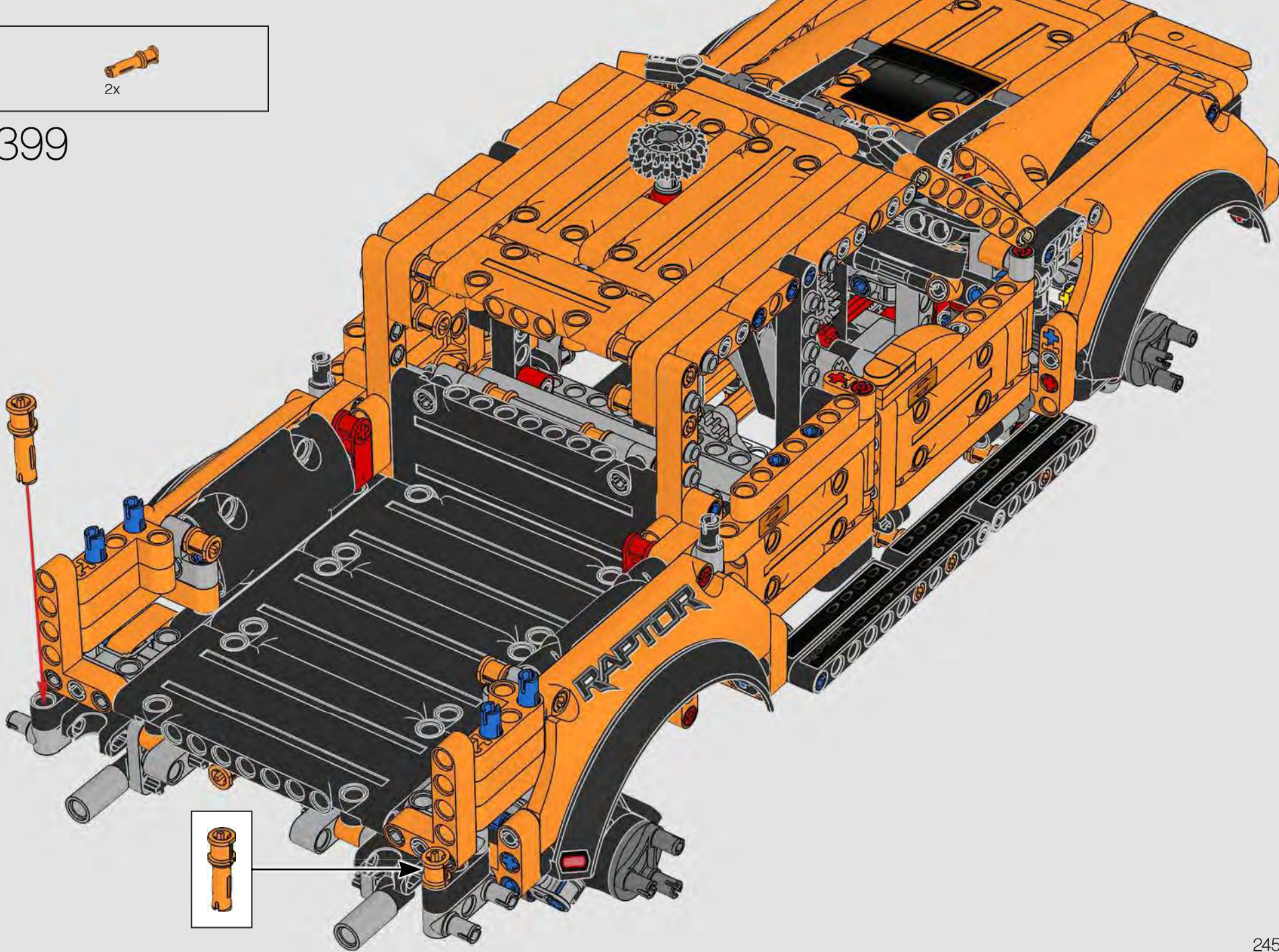



8x

400

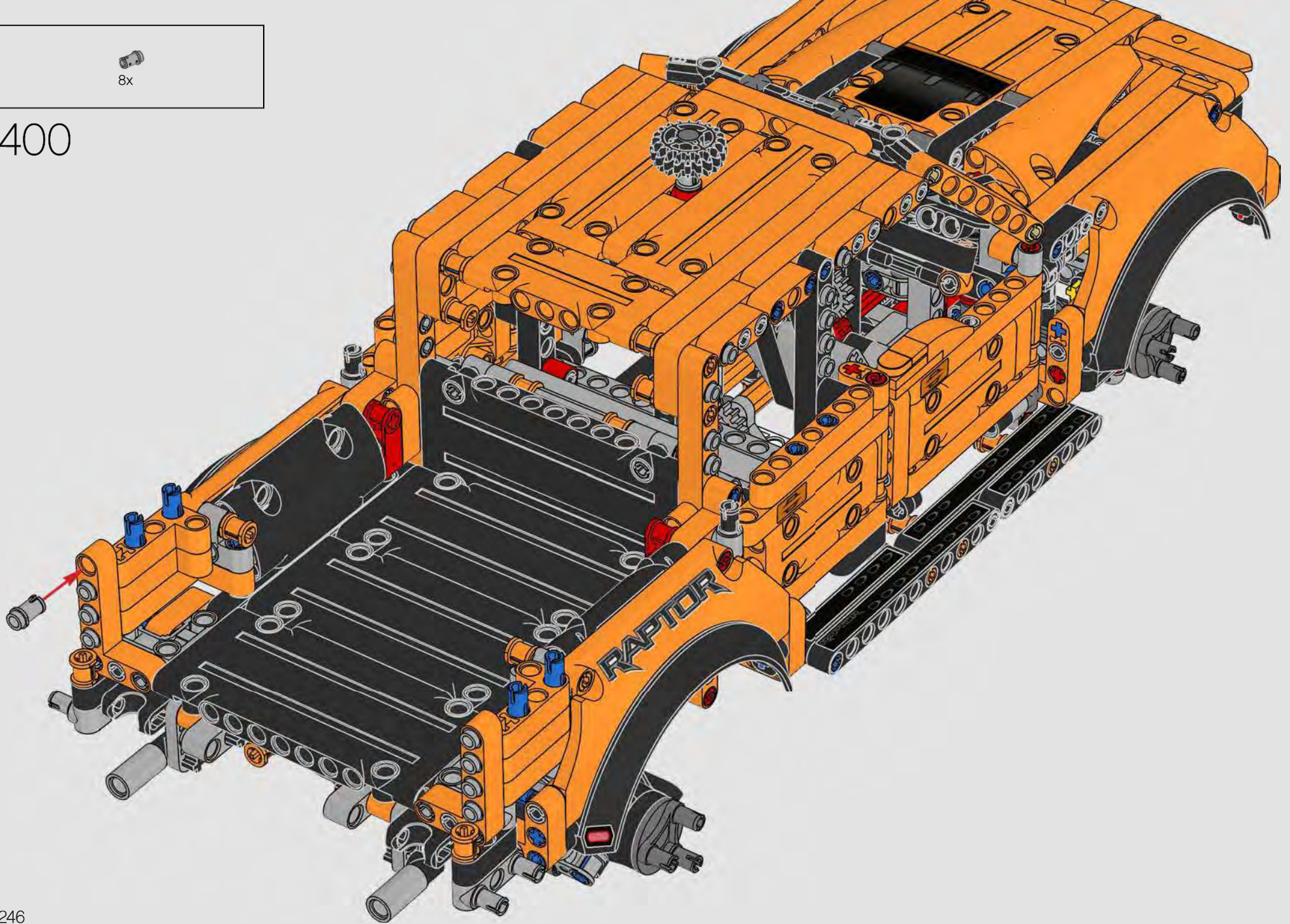



401

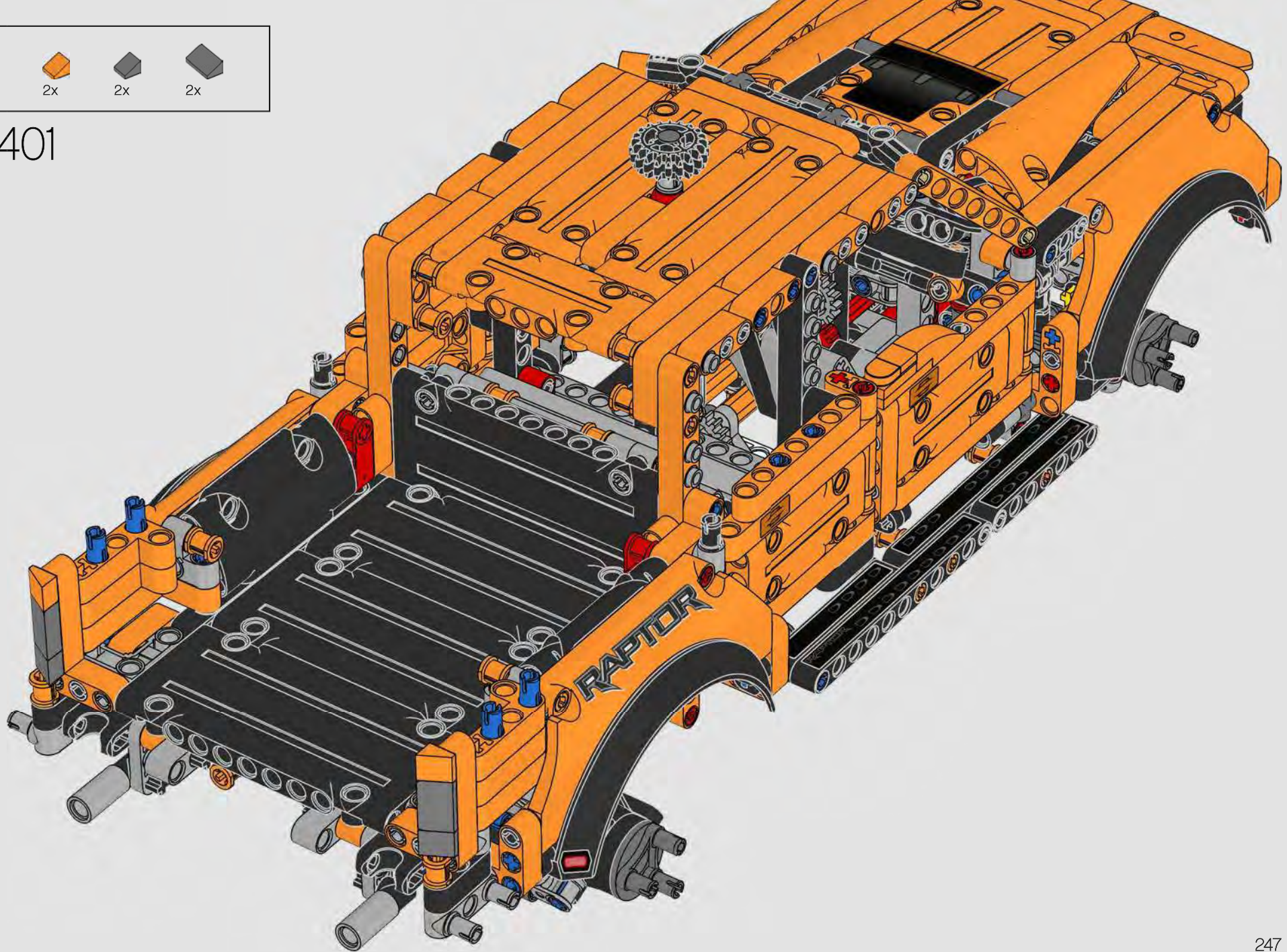

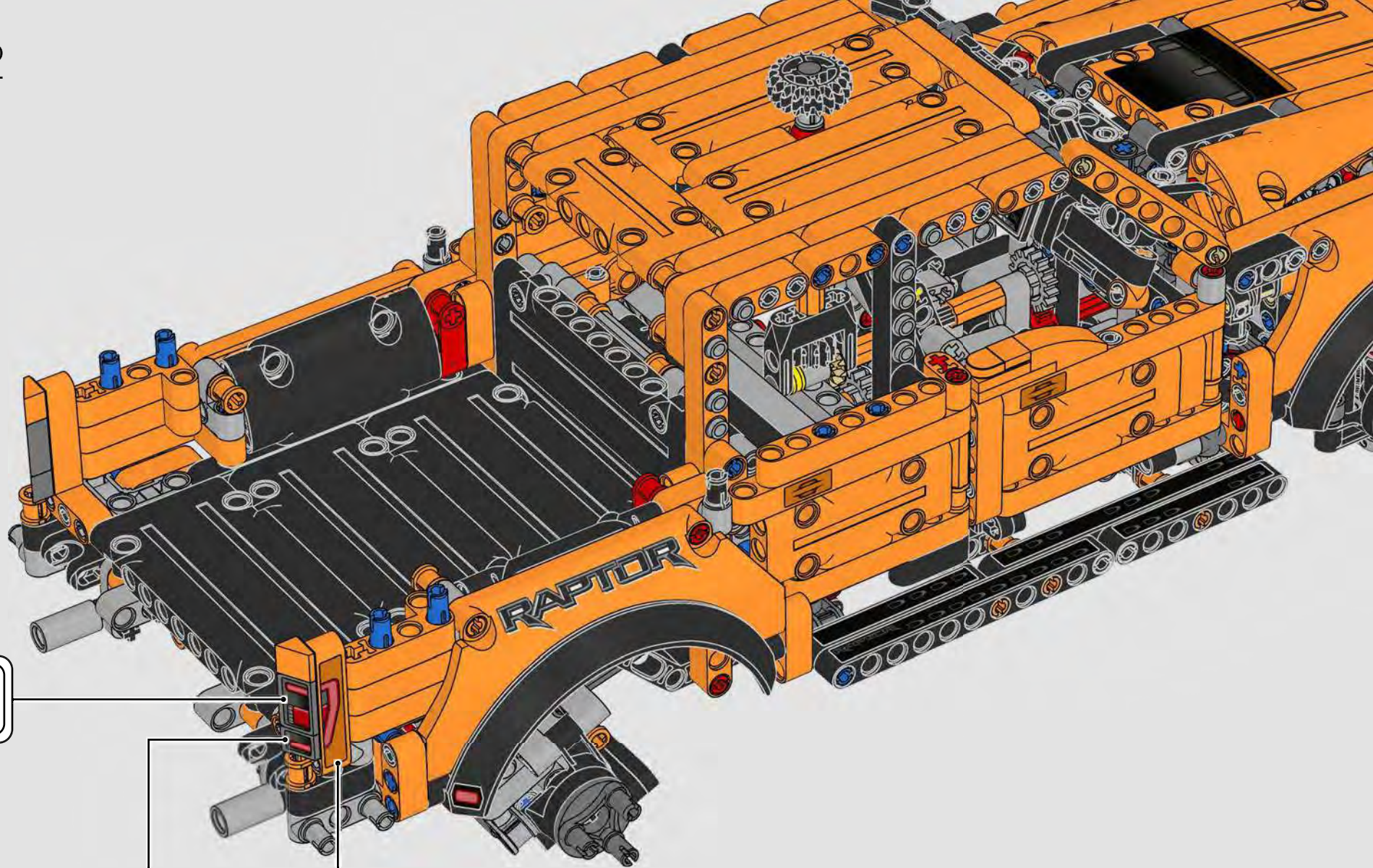

10

13

15



403

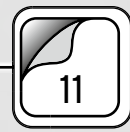
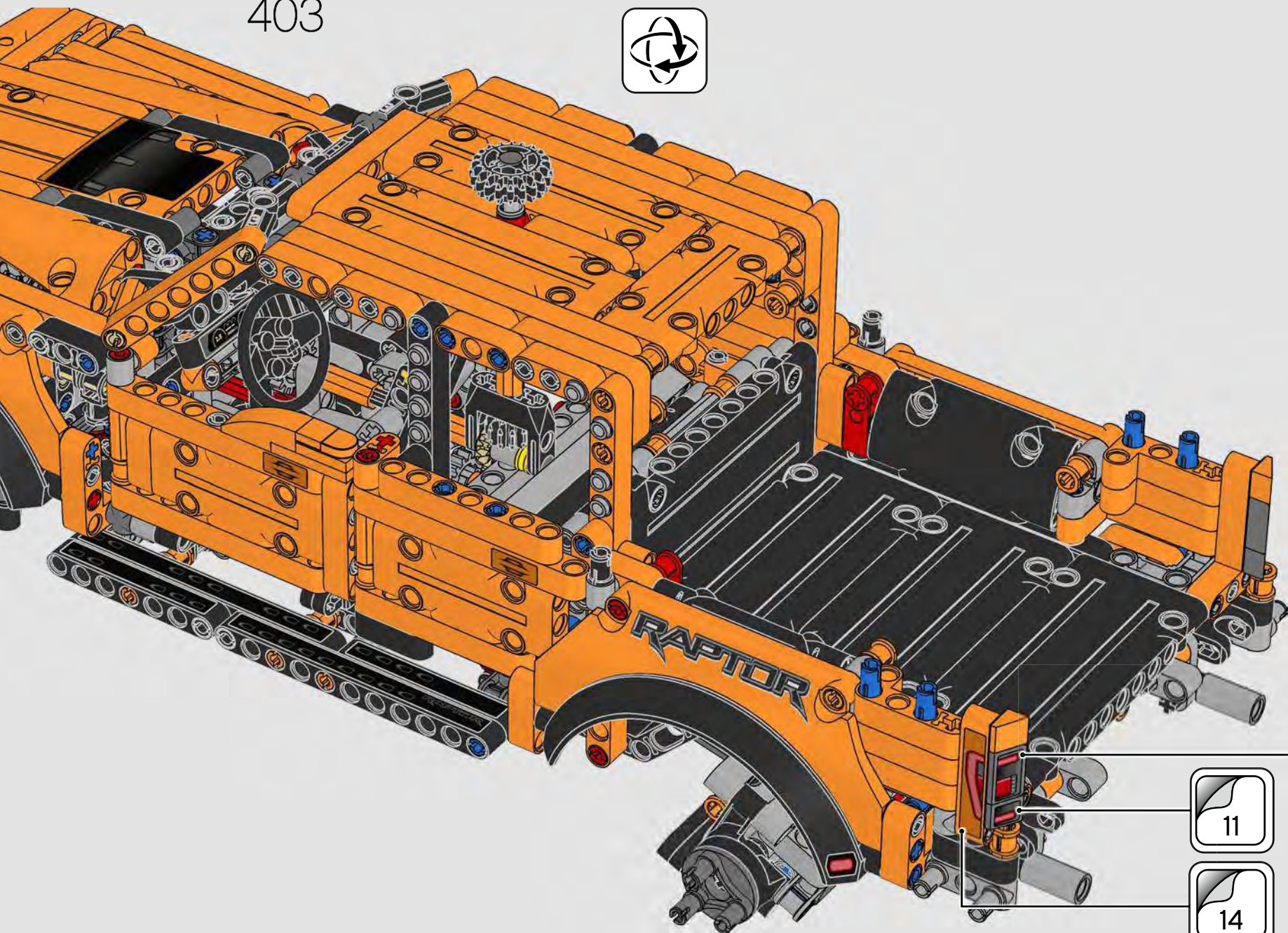

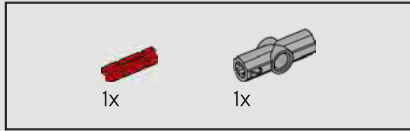
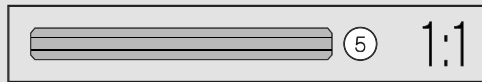

404

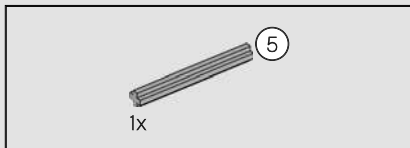
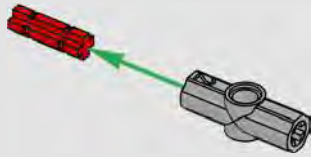

405

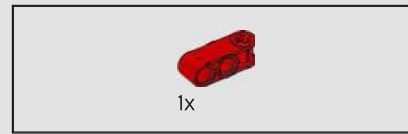
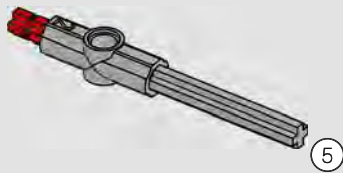

406

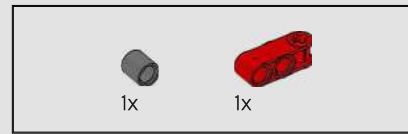
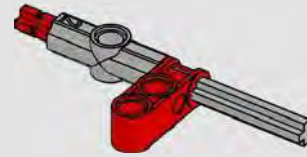

407

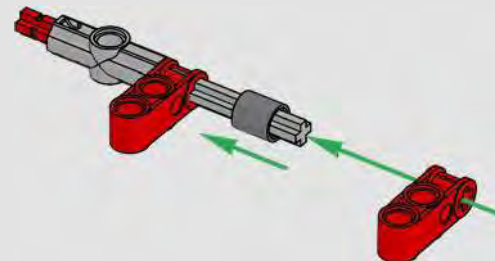

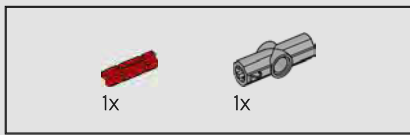

408

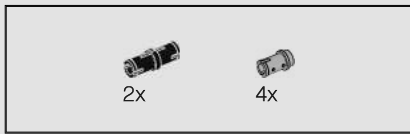
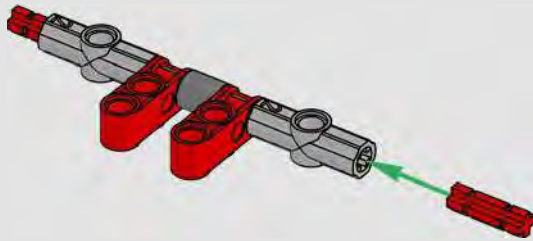

409

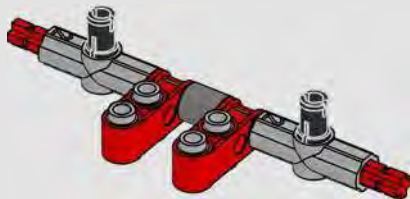

410

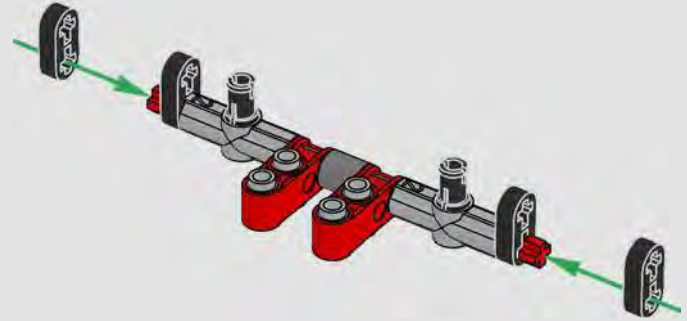

411

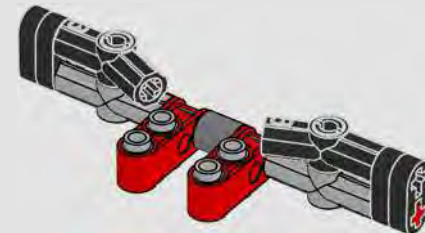

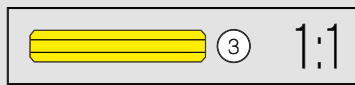
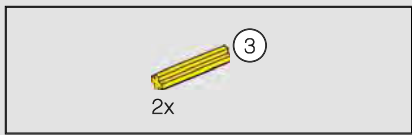

412

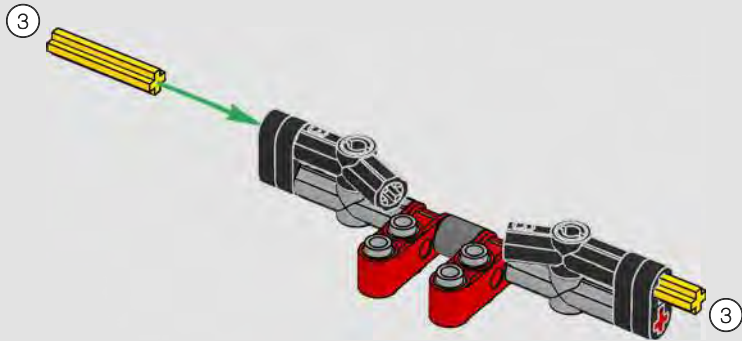

413

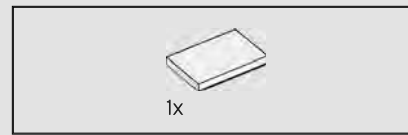
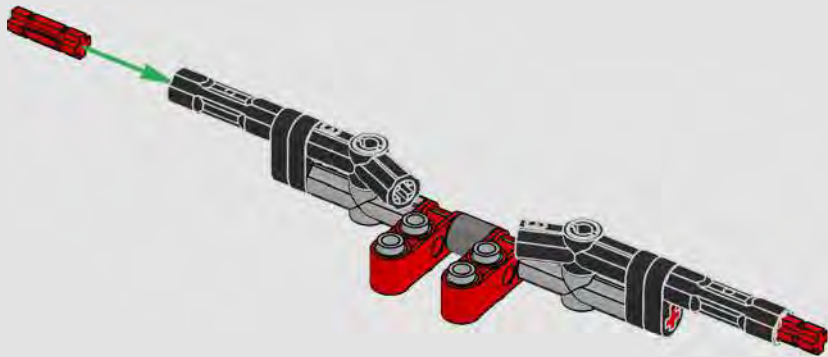

414

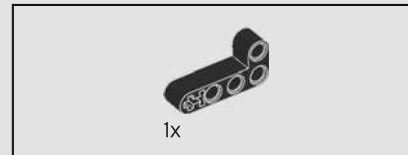
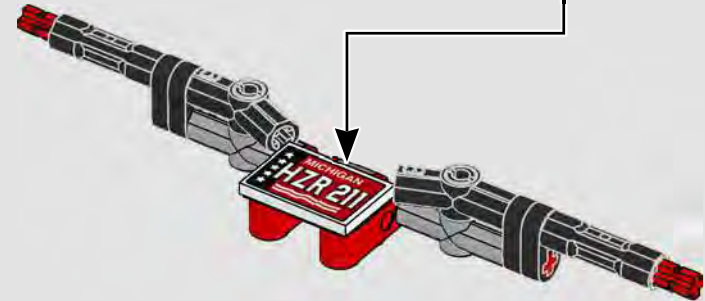
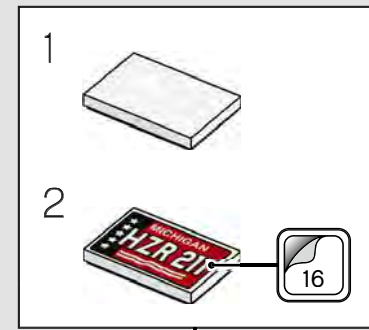

415

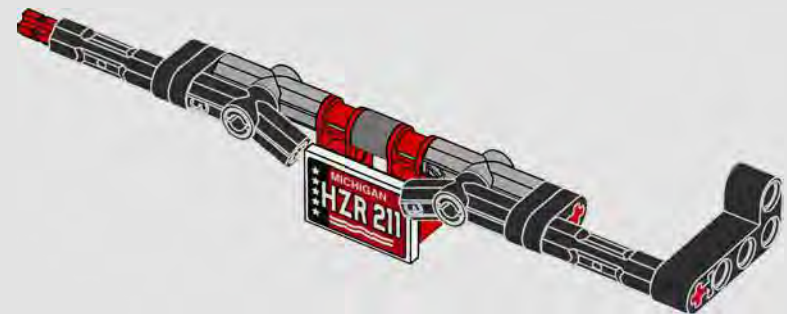

416

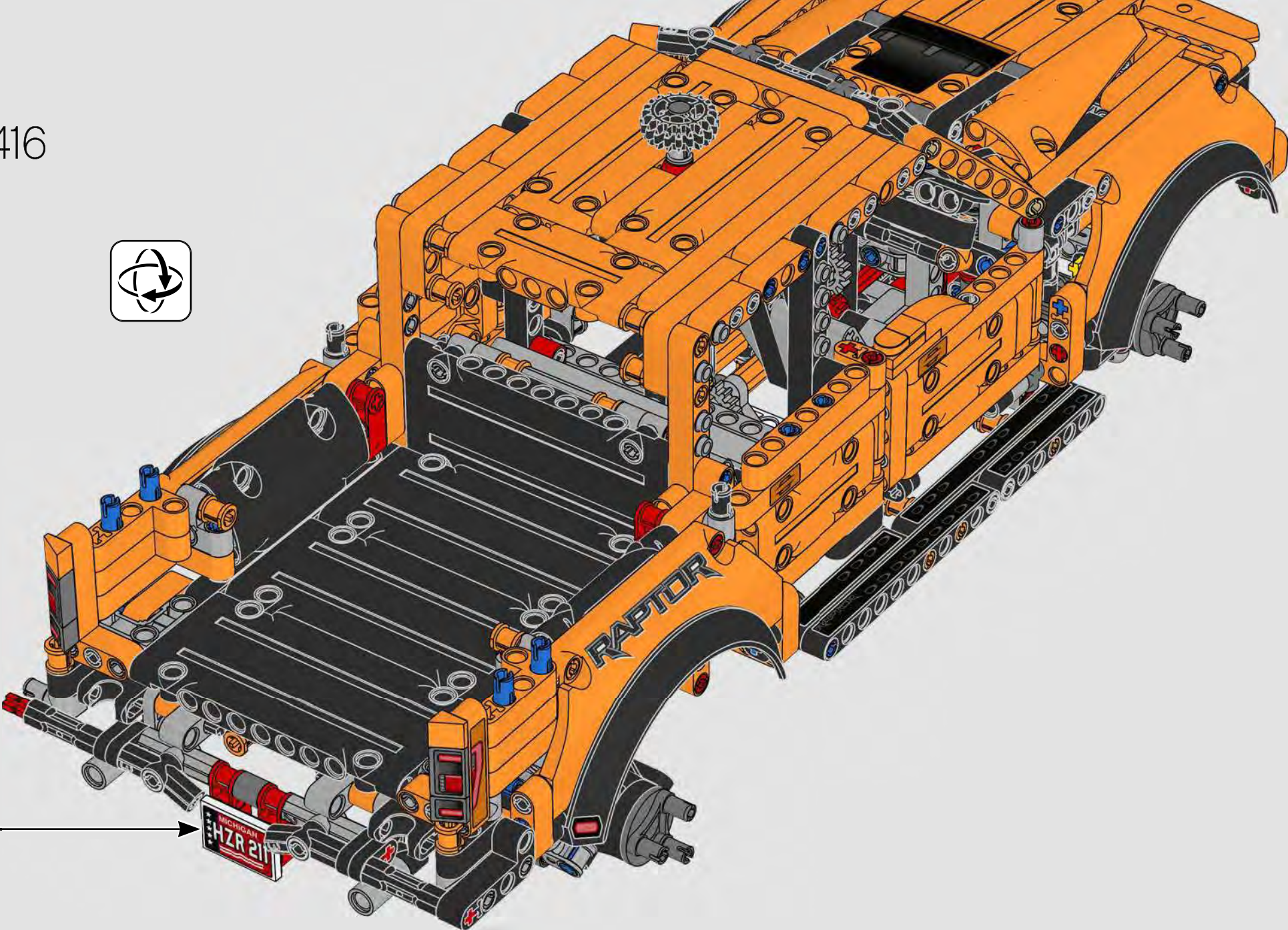

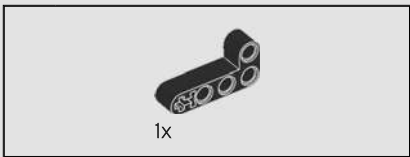

417

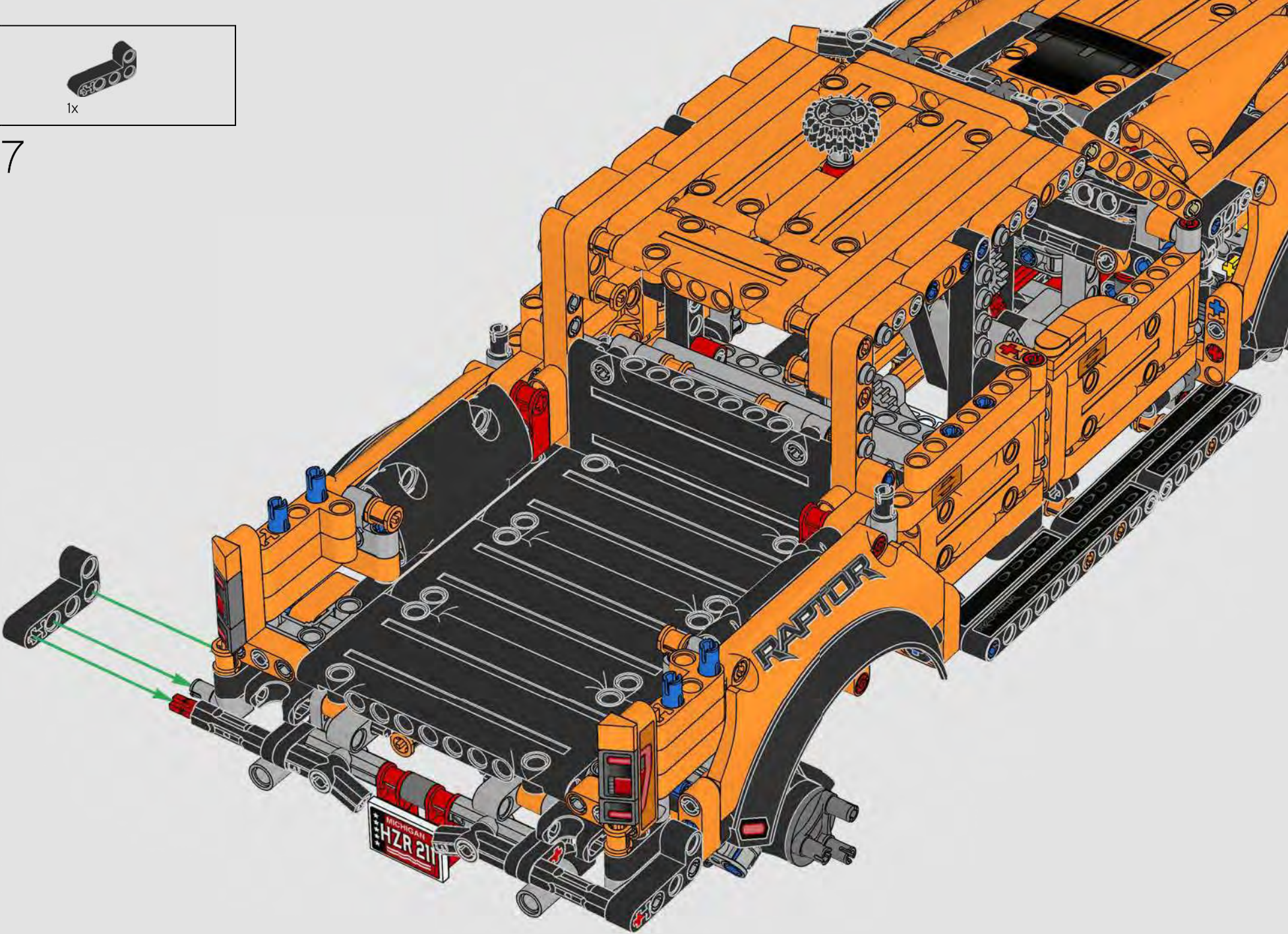

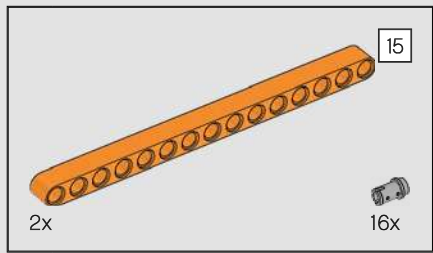

418

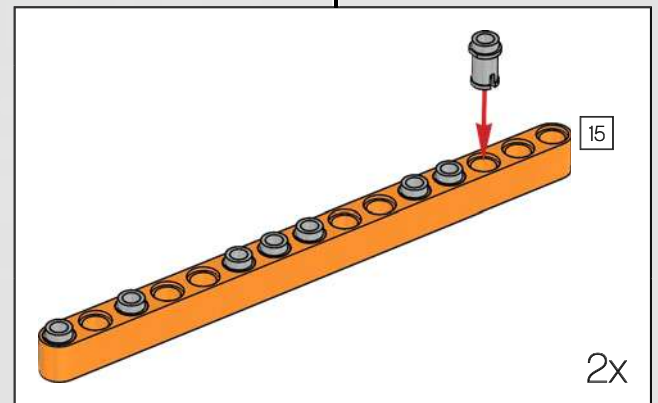
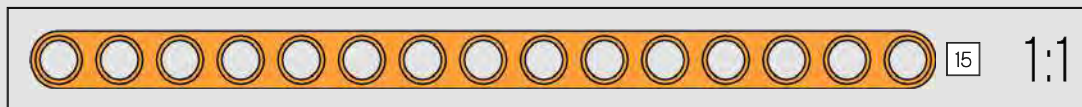
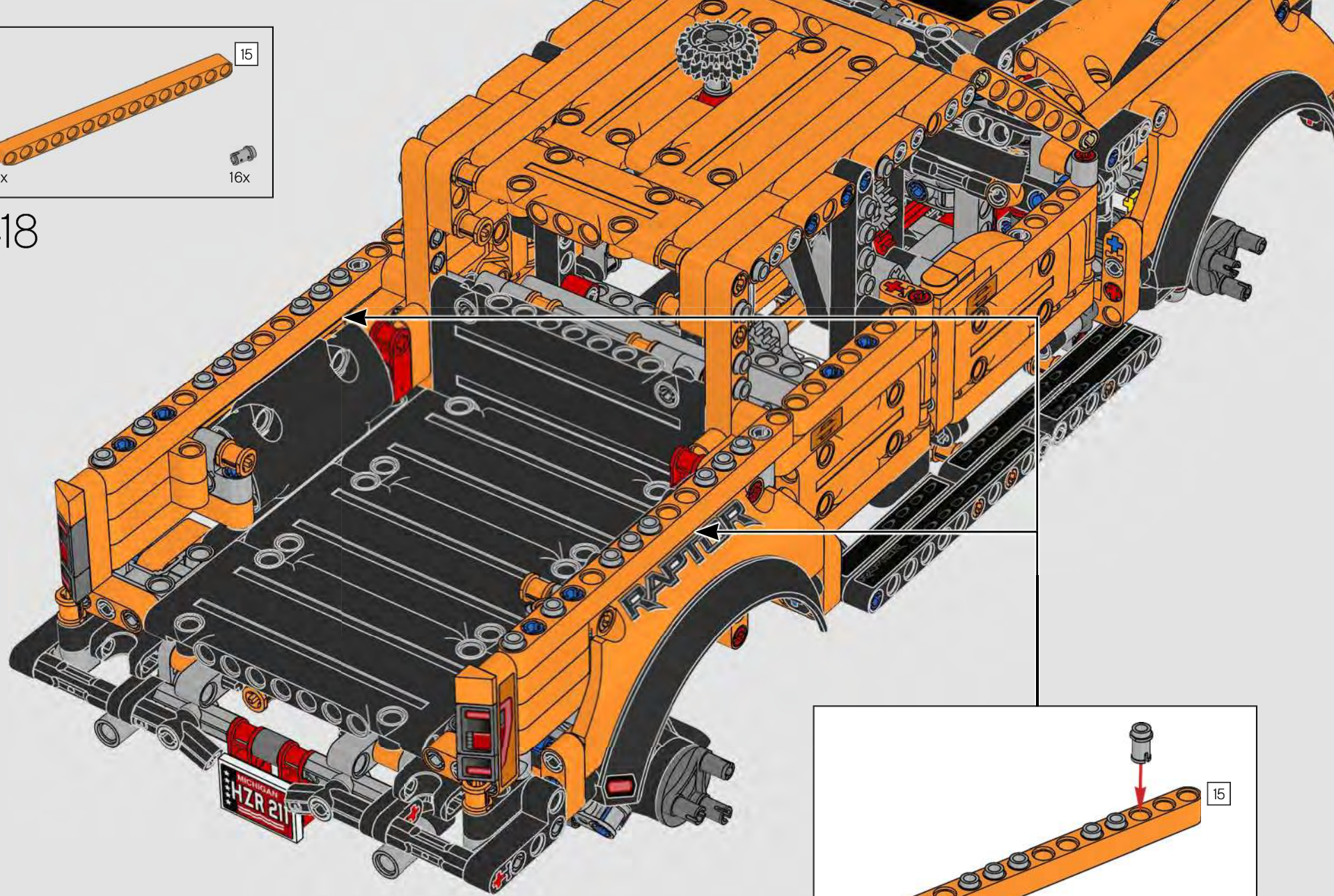

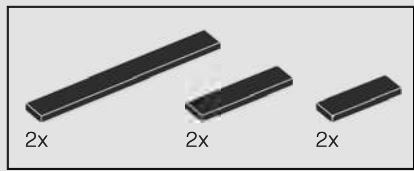

419

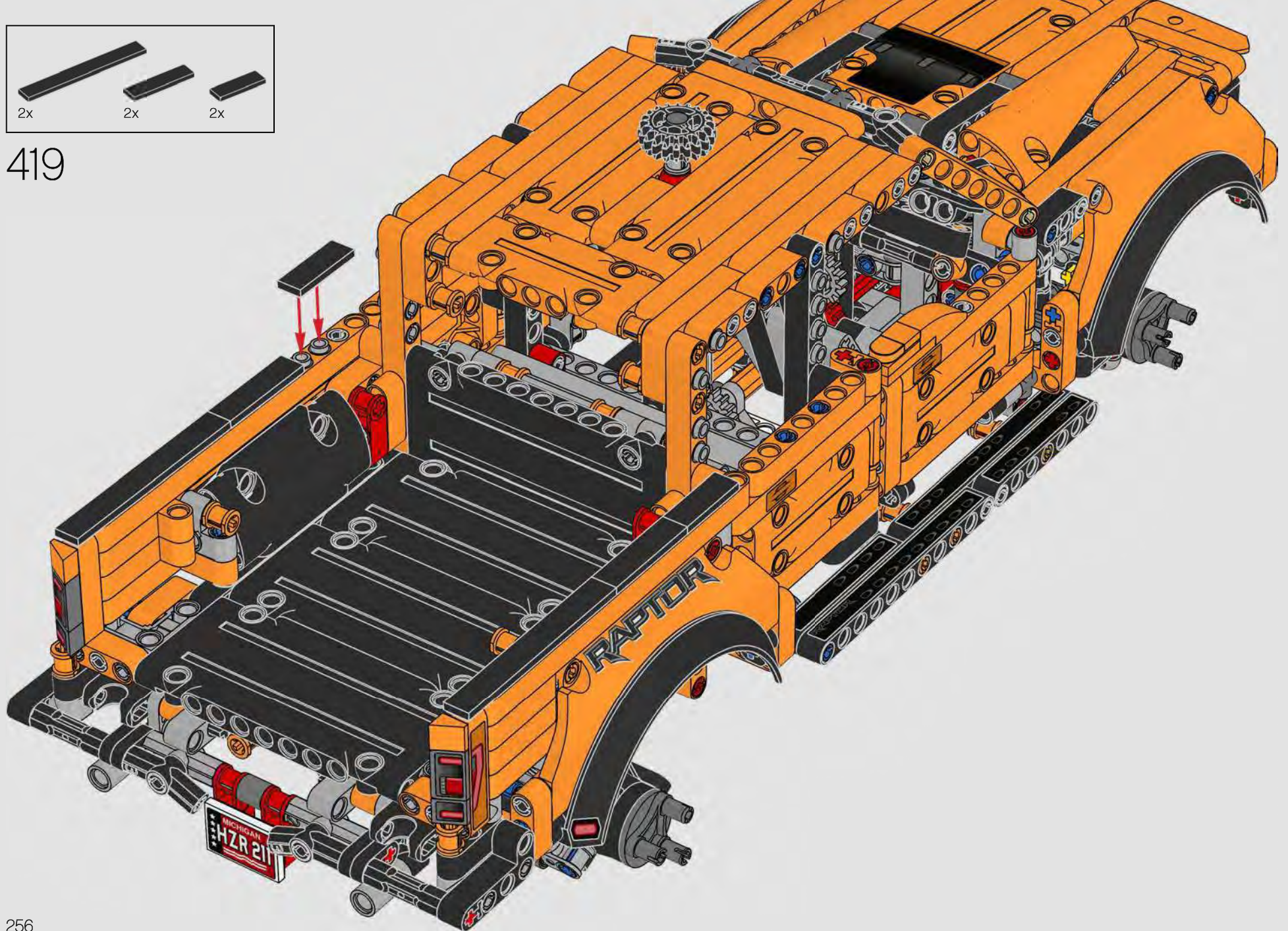



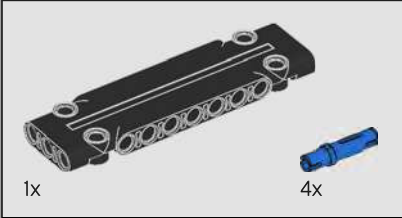

420

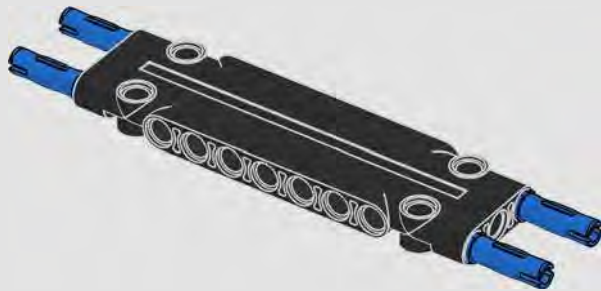

421

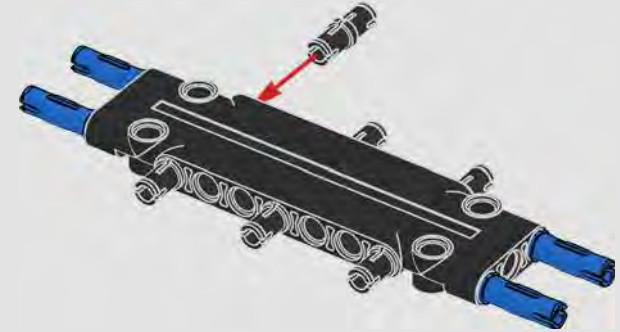

422

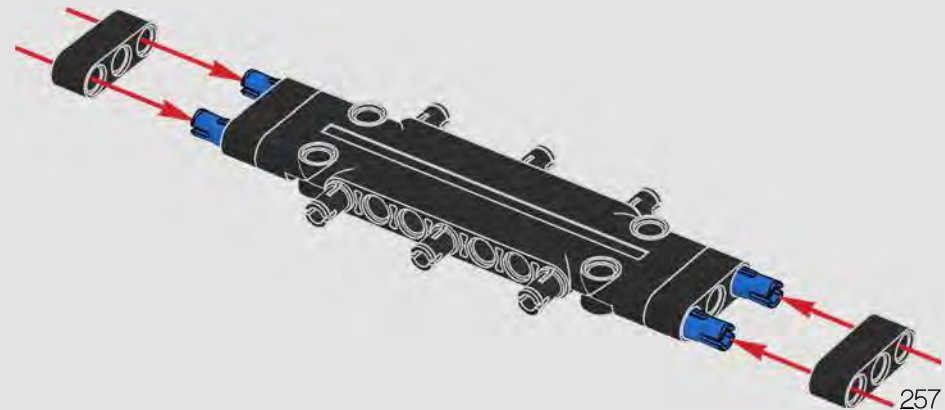

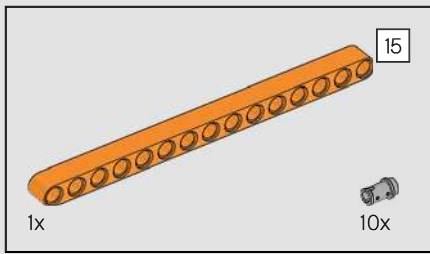

423

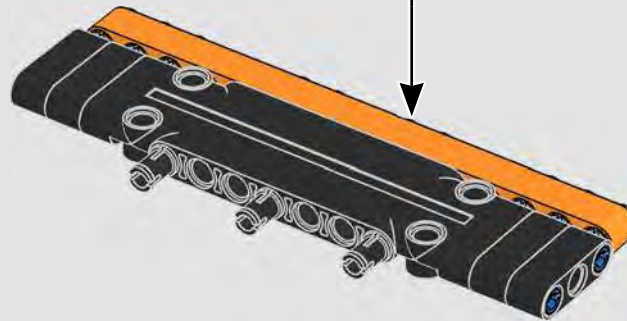
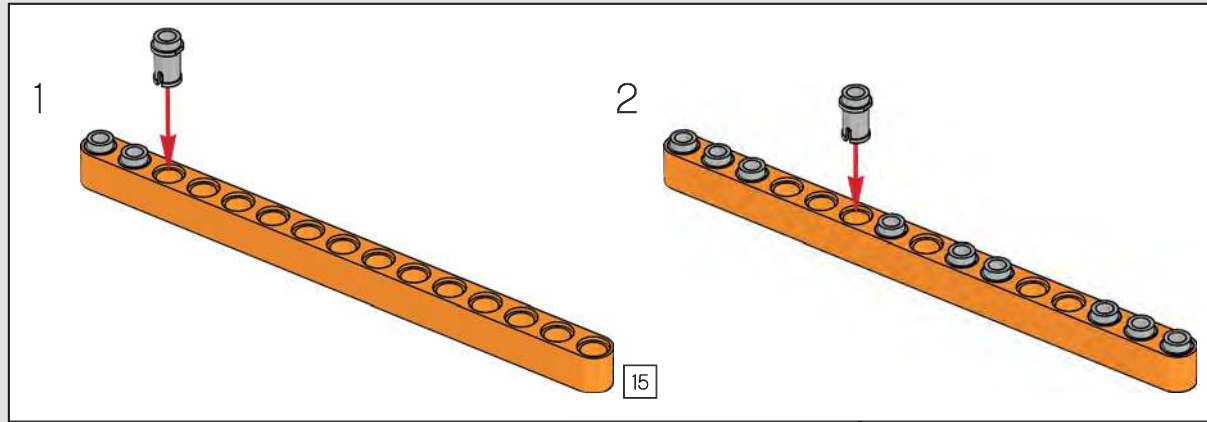
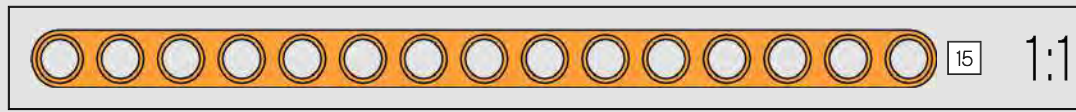

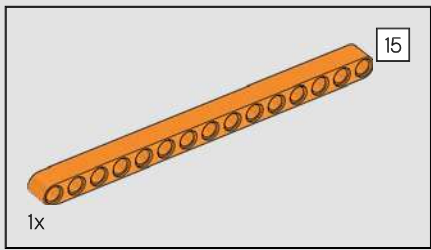

424

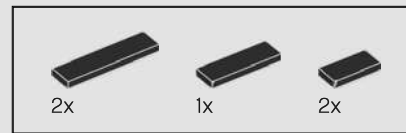
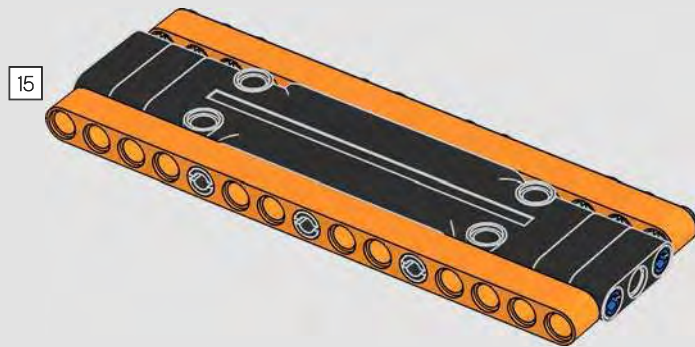

425

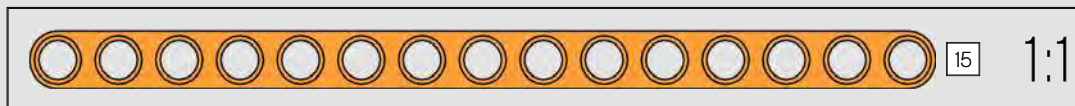
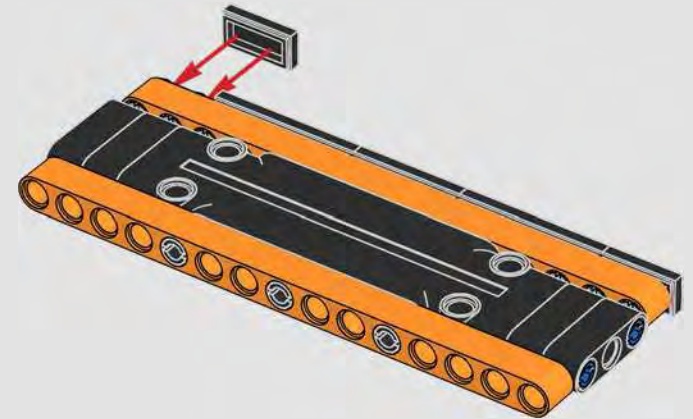

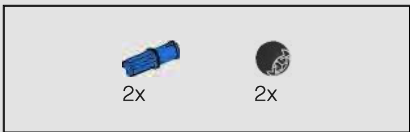

426

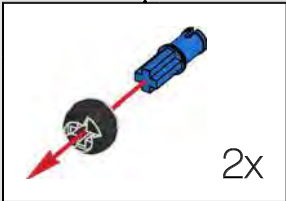
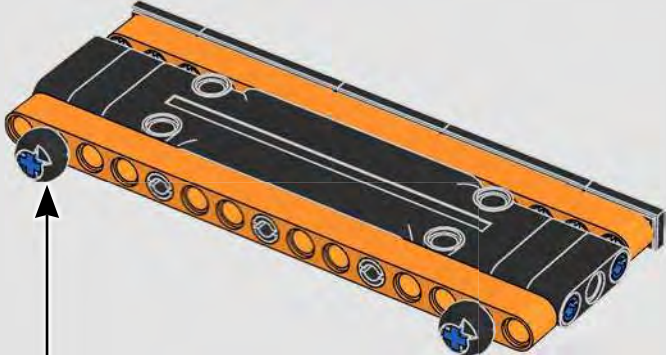

427

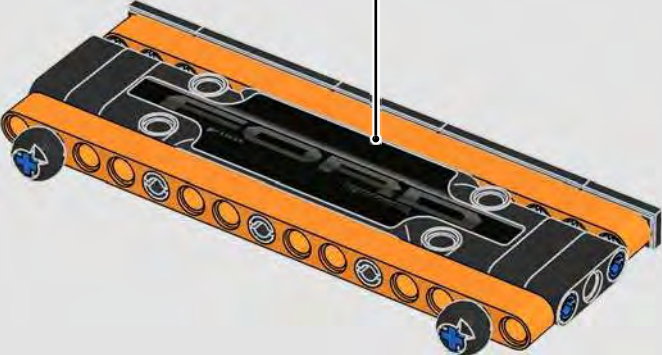

428

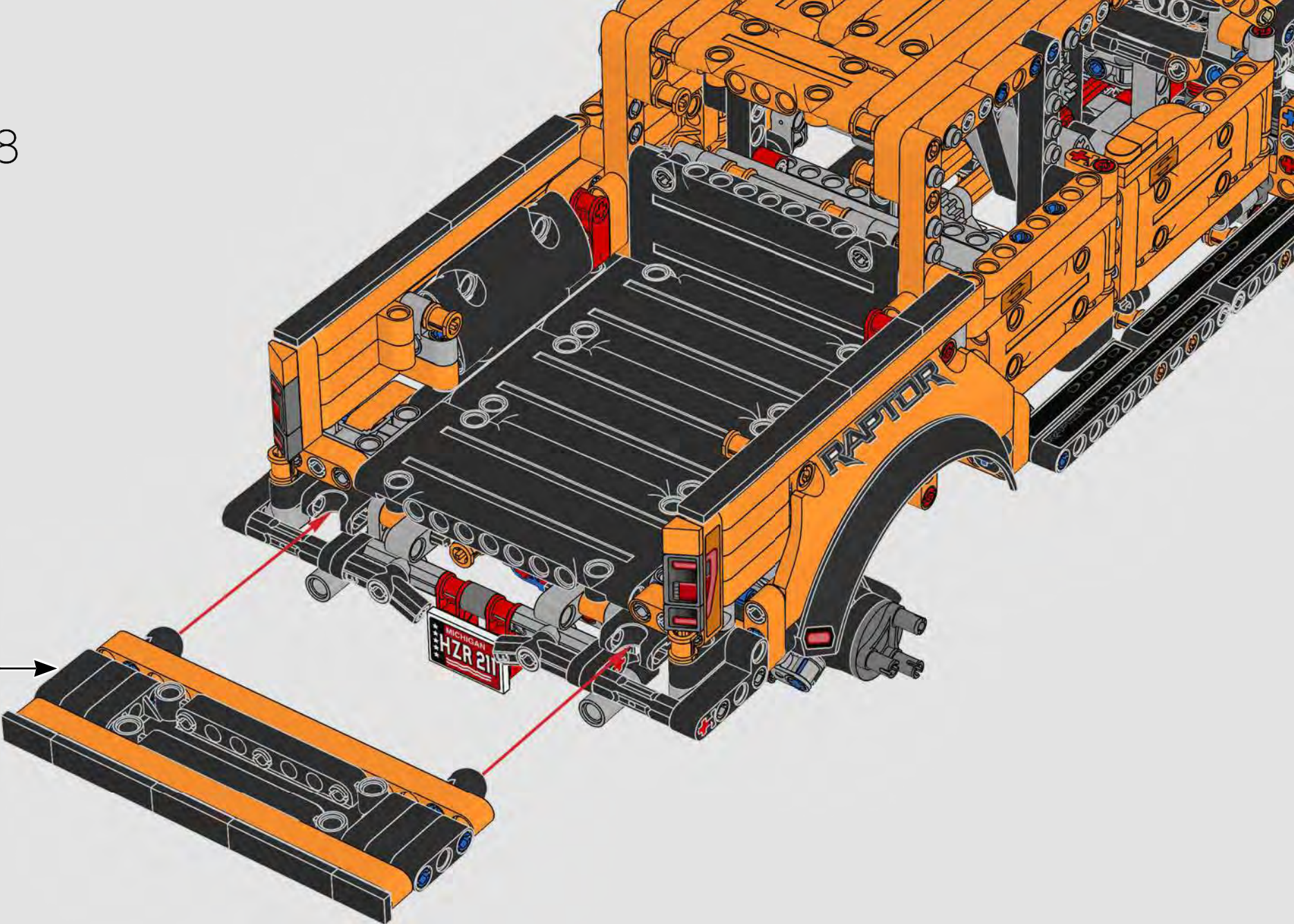

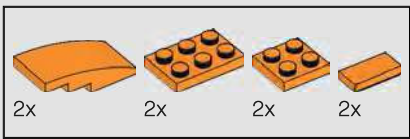

429

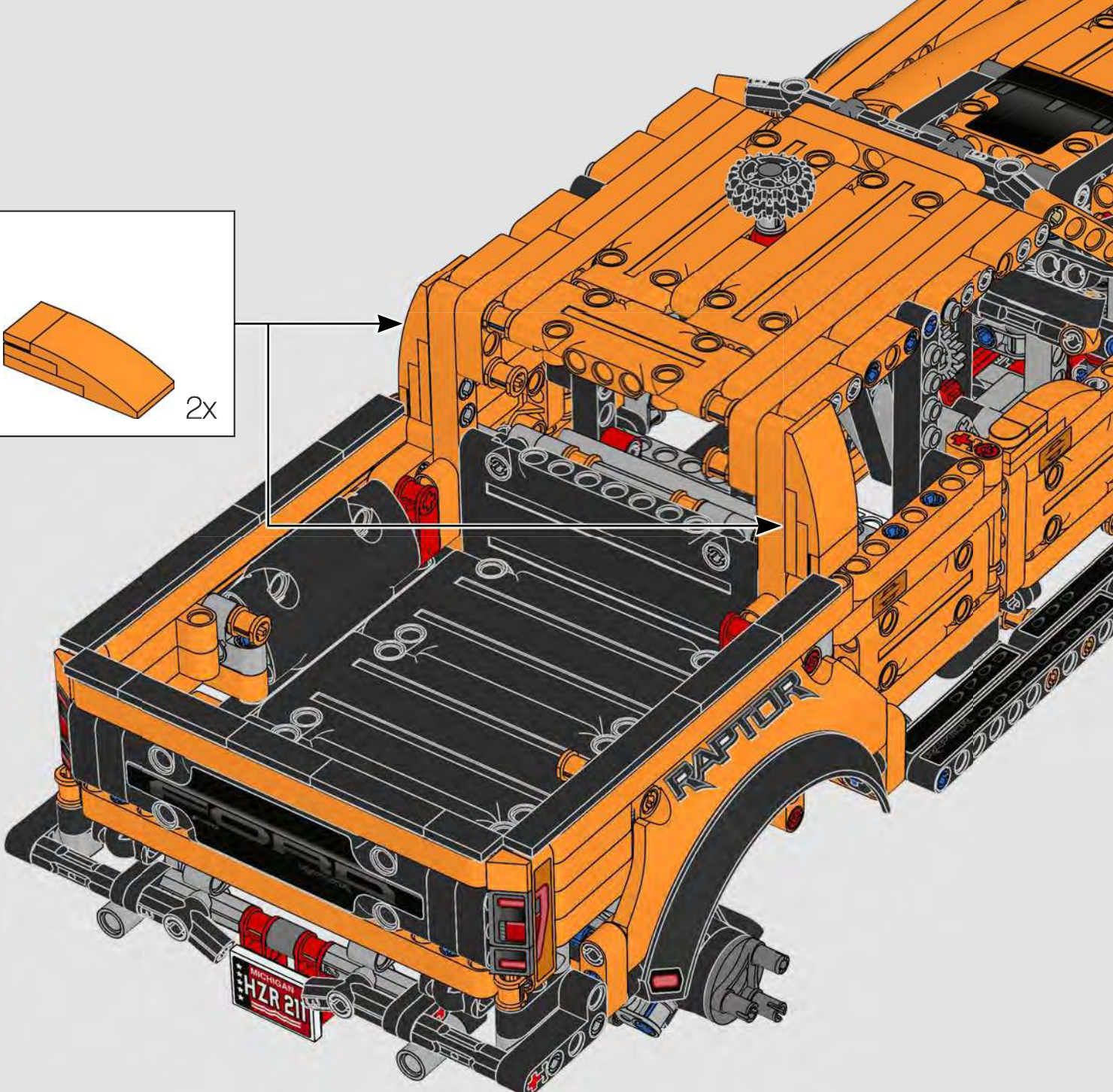
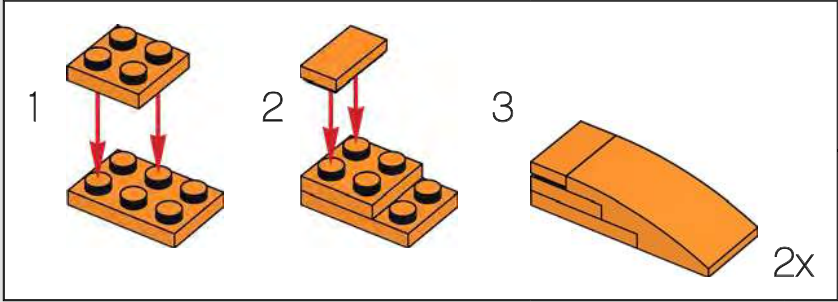

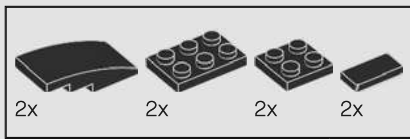

430

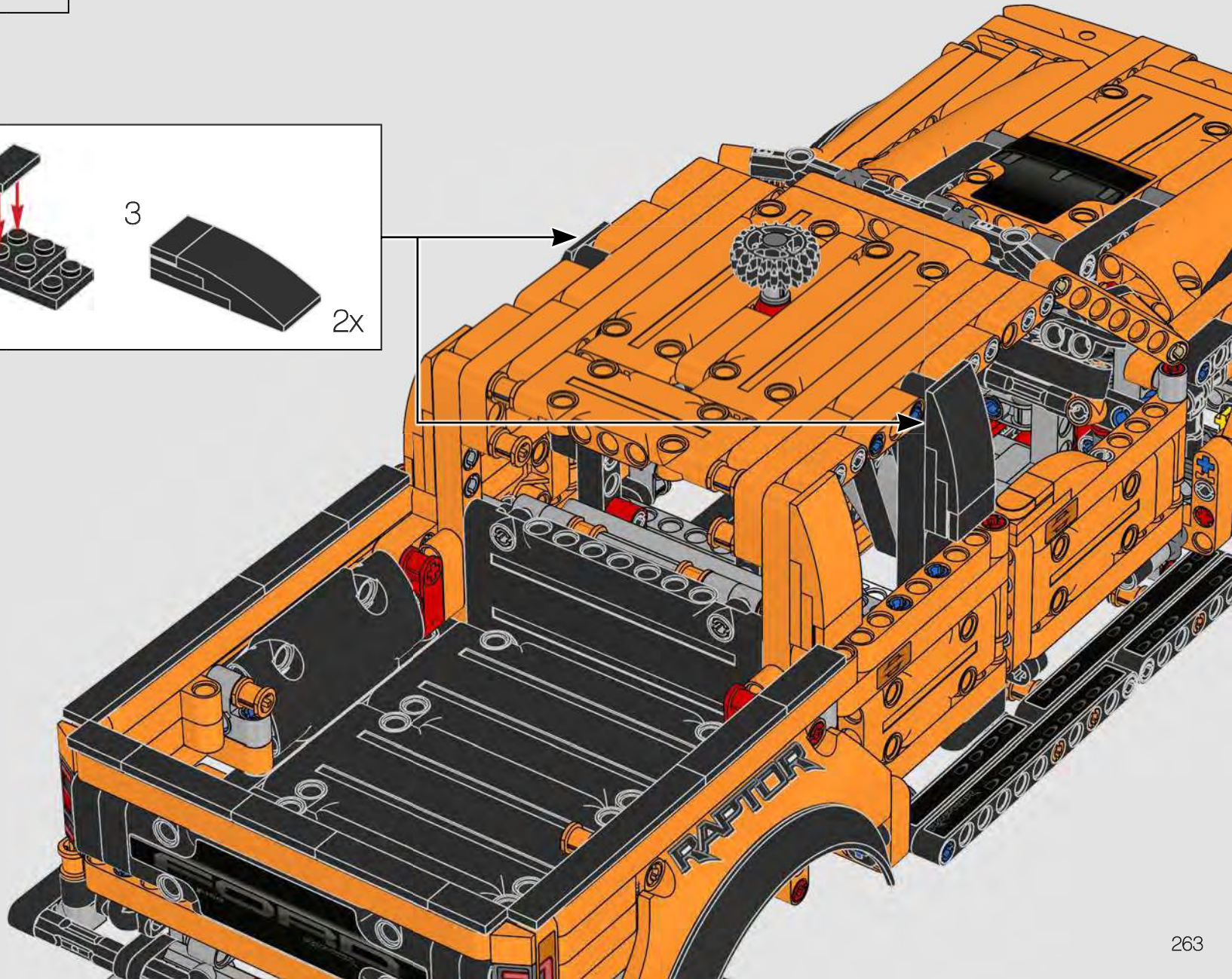
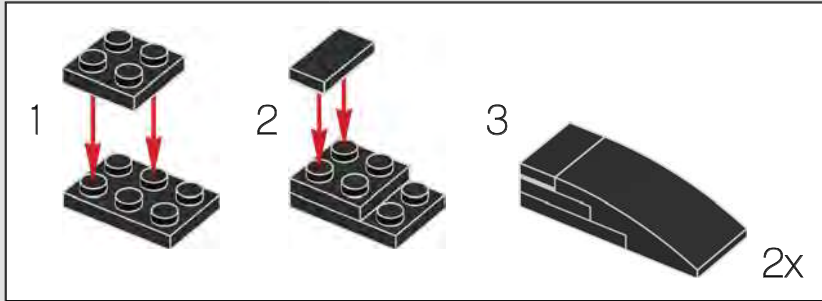

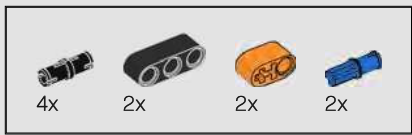

431

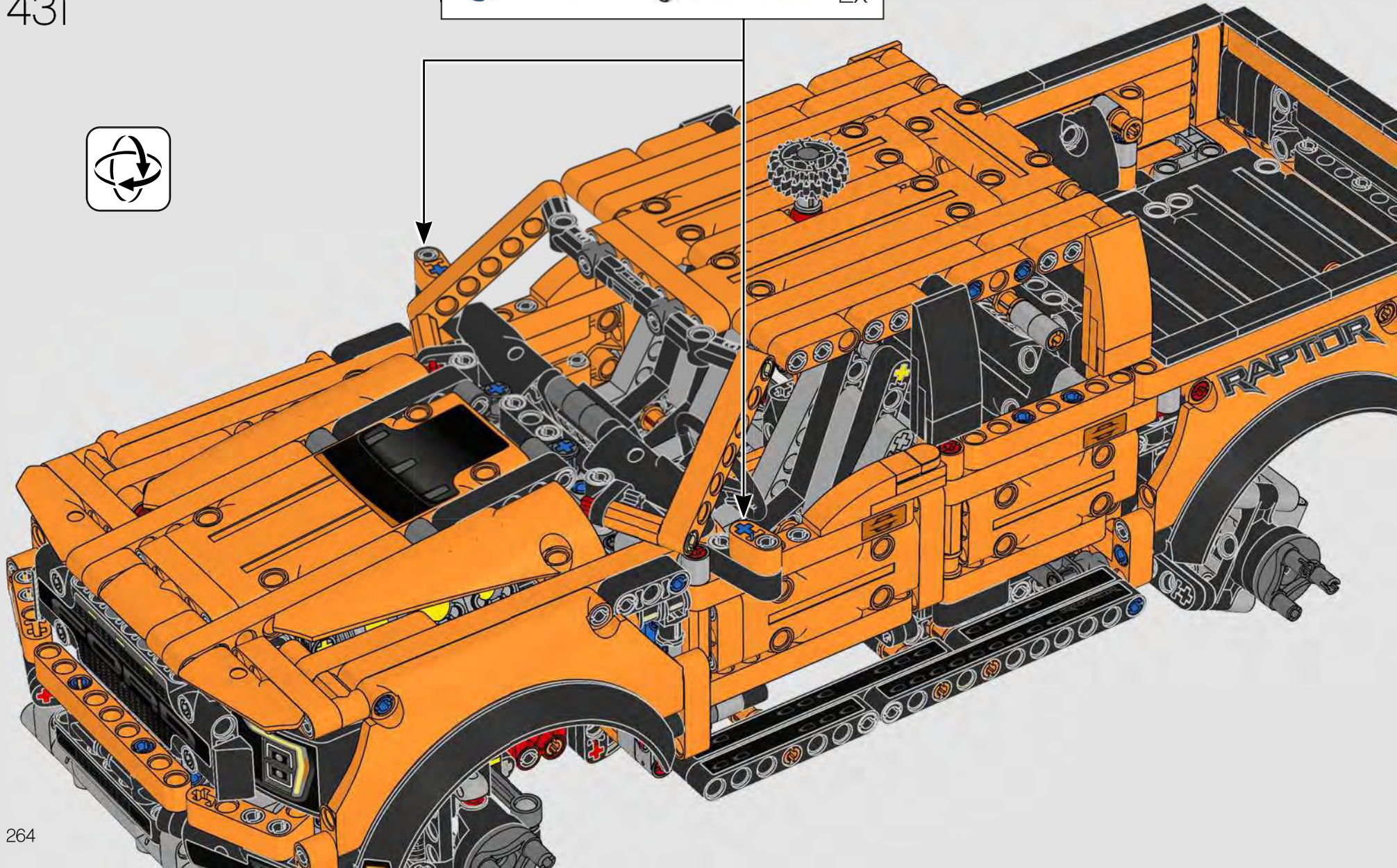
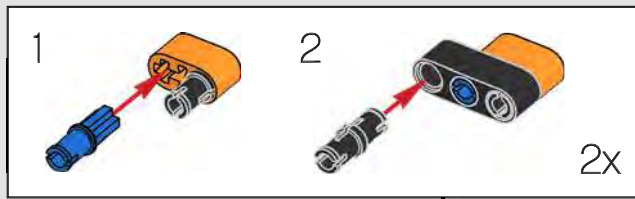



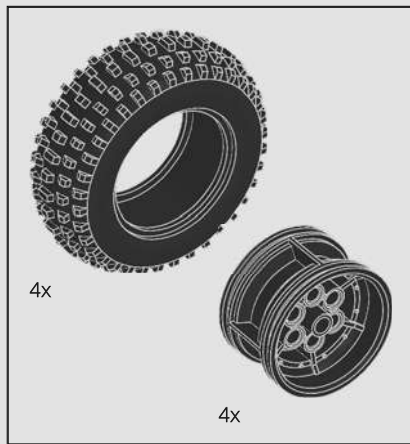

432

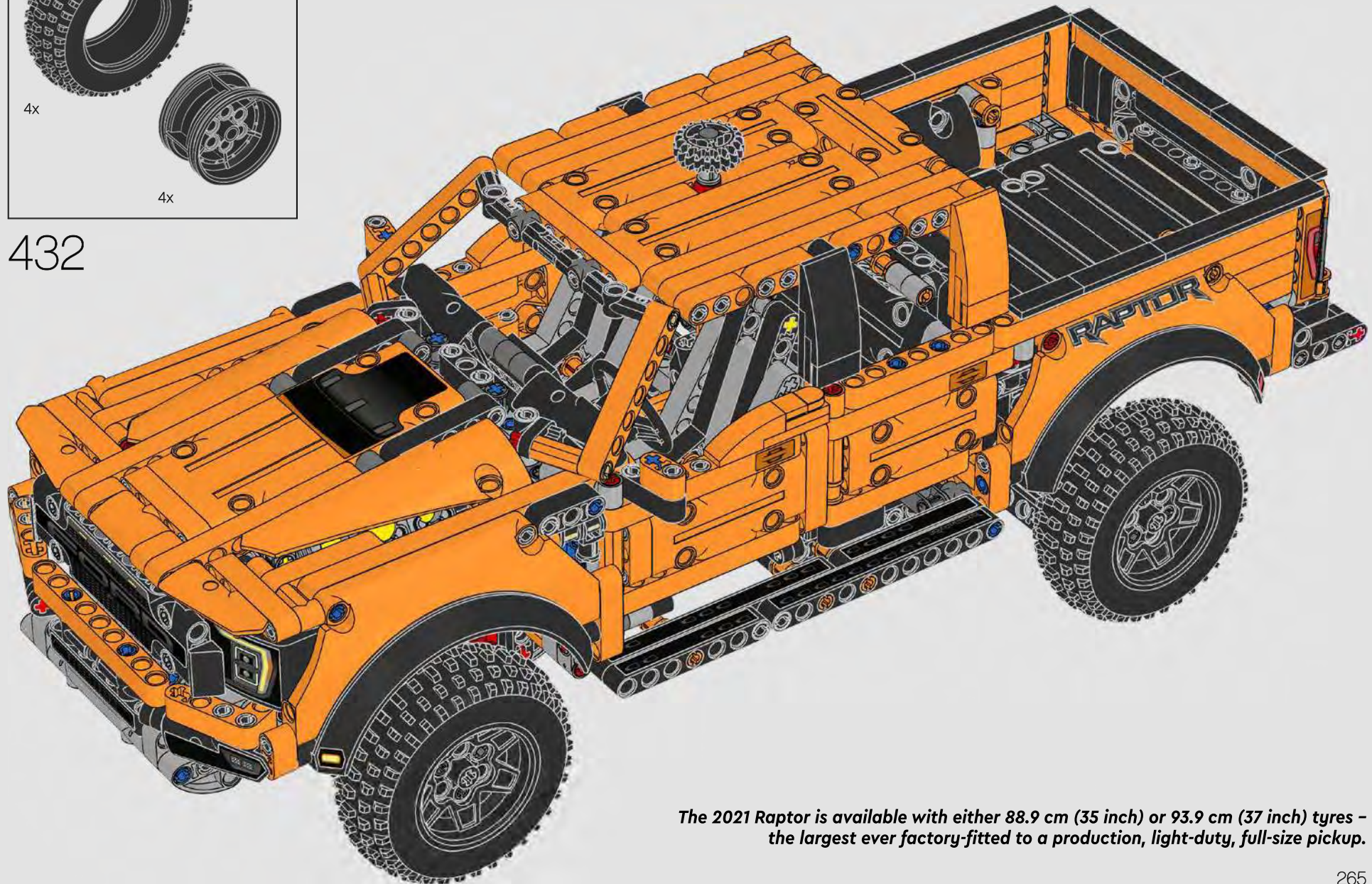

*The 2021 Raptor is available with either 88.9 cm (35 inch) or 93.9 cm (37 inch) tyres - the largest ever factory-fitted to a production, light-duty, full-size pickup.*



3x 6275844  
 21x 6282142  
 69x 4211483  
 2x 4211375  
 21x 6261375  
 6x 4211880  
 2x 6173127  
 6x 4640536  
 2x 6361459  
 6x 6000018  
 2x 6360043  
 3x 6346487  
 3x 6282158  
 1x 6335279

6x 4234251  
 6x 6313453  
 24x 6271831  
 4x 6331428  
 4x 6247352  
 11x 4211639  
 16x 4211713  
 16x 4211651  
 2x 6055519  
 1x 6257136  
 4x 6279885

1x 6296843  
 9x 6102449  
 13x 6102449  
 3x 4522934  
 4x 4629802  
 2x 6338588  
 2x 6358258  
 1x 4580014  
 6x 6358259

1x 6358253  
 1x 6358255  
 2x 4125278  
 1x 6358254  
 4x 6305545  
 12x 6271832  
 2x 6054529  
 11x 6135086  
 2x 6339023

2x 6344851  
 6x 6332584  
 6x 6259825  
 14x 6265128  
 20x 6143028  
 2x 4251969  
 2x 6147047  
 3x 6143014  
 14x 6143015  
 7x 6339024  
 5x 6358256

2x 6332570  
 53x 4206482  
 2x 6331024  
 6x 6279026  
 128x 6299413  
 2x 4558595  
 2x 4504371  
 1x 6352662  
 1x 6340604  
 2x 4177932  
 2x 4188771  
 2x 4159007  
 43x 6347790  
 17x 6102618

2x 6271167  
 6x 4112203  
 2x 4119474  
 21x 6130007  
 1x 6130009  
 22x 6100030  
 2x 4504378  
 2x 4567887  
 2x 6280395  
 10x 6167281  
 1x 6296844

10x 6276984  
 4x 4610378  
 9x 6083620  
 1x 4525184  
 3x 4508553  
 4x 4629920  
 2x 6027566  
 2x 6027565



**Customer Service**  
 Kundenservice  
 Service Consommateurs  
 Servicio Al Consumidor  
 LEGO.com/service or dial

 : 00800 5346 5555  
 : 1-800-422-5346



# FEEDBACK AND WIN



## FEEDBACK AND WIN

Your feedback will help shape the future development of this product series.

Please visit:

## FEEDBACK UND GEWINNEN

Dein Feedback trägt zur Weiterentwicklung dieser Produktreihe bei.

Geh auf:

## COMMENTEZ ET GAGNEZ

Vos commentaires nous aideront à concevoir les futurs produits de cette gamme.

Rendez-vous sur :

## COMENTA Y GANA

Tu opinión nos ayudará a dar forma al desarrollo de esta serie de productos en el futuro.

Visita:

## 反馈有奖

您的反馈将有助于我们在今后改进本系列产品。

请访问：

[LEGO.com/productfeedback](https://www.lego.com/productfeedback)

By completing, you will automatically enter a drawing to win a LEGO® set.

Terms & Conditions apply.

Durch Ausfüllen nimmst du automatisch an der Verlosung eines LEGO® Preises teil.

Es gelten die Teilnahmebedingungen.

En envoyant vos commentaires, vous serez automatiquement inscrit(e) à un tirage au sort qui vous permettra de remporter un prix LEGO®.

Offre soumise à conditions.

Al contestar, participarás automáticamente en el sorteo y podrás ganar un set LEGO®.

Sujeto a Términos y Condiciones.

完成我们的反馈调查，即可自动进入抽奖环节，赢取乐高®套装。

适用《条款和条件》。

LEGO and the LEGO logo are trademarks of the LEGO Group. ©2021 The LEGO Group.

Ford Trademarks and Trade Dress used under license to The LEGO Group of companies.

